



MX-GIR



MISCELATORI SOMMERSIBILI

POTENZA: 1,8 ÷ 18,5 kW

VELOCITÀ ROTAZIONE: 330 ÷ 354 giri/min

Ideali per la miscelazione ed omogeneizzazione di liquidi in impianti industriali e di depurazione e per il trattamento di liquami zootecnici

SUBMERSIBLE MIXERS

POWER: 1,8 ÷ 18,5 kW

SPEED: 330 ÷ 354 r.p.m.

An ideal solution for mixing and homogenising liquids in industrial and wastewater treatment plants and for zootechnic fluids processing.

I **miscelatori sommersibili** S.C.M. Technologie si distinguono per la qualità dei materiali di costruzione impiegati e per il design delle eliche, che pongono queste macchine ai vertici nella resa idraulica.

S.C.M. Technologie **submersible mixers** stand out for the quality of the production materials used and the design of the propellers, which put these machines at the top of their class for hydraulic efficiency.



www.scmttec.com

Il **miscelatore sommerso MX-GIR** è composto da un motoriduttore accoppiato ad un'elica, generalmente a tre pale, altamente performante. Pensati per la miscelazione di liquami con elevato contenuto di solidi e di sabbia, e per il trattamento di liquami zootecnici, i miscelatori a giri lenti della serie MX-GIR sono applicati con buoni rendimenti anche in impianti di depurazione civili. Quando per esempio si ha necessità di mantenere in sospensione i solidi è infatti opportuno impiegare miscelatori con eliche di grandi dimensioni e a basso numero di giri.

Su richiesta può essere fornita un'apposita struttura di sollevamento dotata di argano manuale e sistema di orientamento del miscelatore. Il sistema di orientamento consente di direzionare il flusso evitando la formazione di zone morte all'interno della vasca.

Protezioni termiche di serie. Sonda di umidità non applicabile.

The **submersible mixer MX-GIR** is composed of a motor and gearbox coupled to a high-efficiency impeller, generally a three-blades one. Designed for mixing of sewage with high content of solids and sand, and for processing zootechnical fluids, the slow-speed mixers of MX-GIR series are also often applied in municipal water treatment plants with excellent results. When the purpose, for instance, is to keep solids in suspension, it is advisable to utilize mixers having larger impeller diameter and low rotational speed.

A special lifting device, consisting of a manual winch and a mixer orientation bracket, is available upon request. The mixer orientation system, supplied with the lifting equipment, allows the flow to be directed to avoid formation of dead zones inside the tank.

Motor equipped with thermal protections. Humidity probe not applicable.

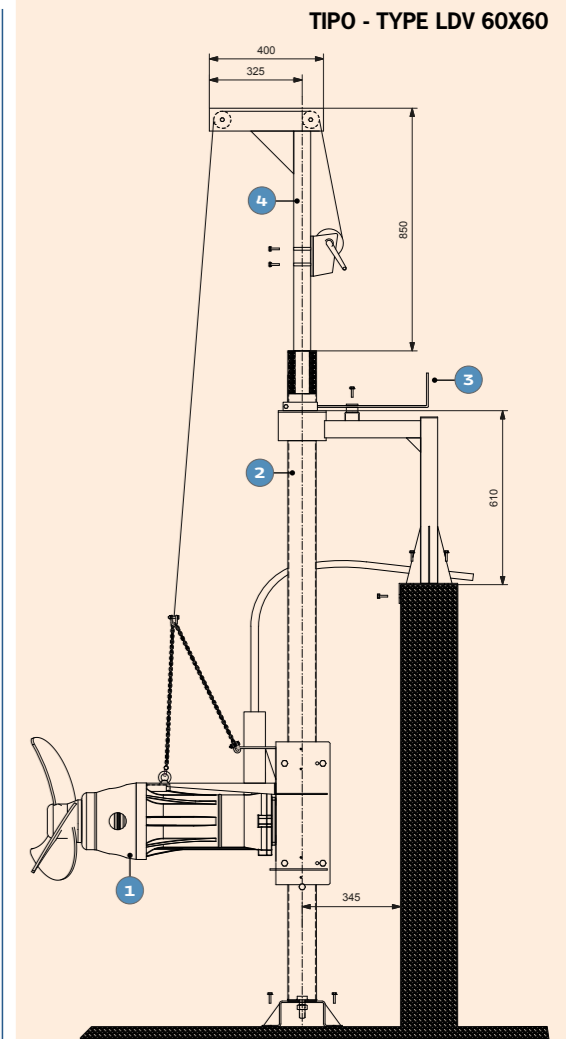
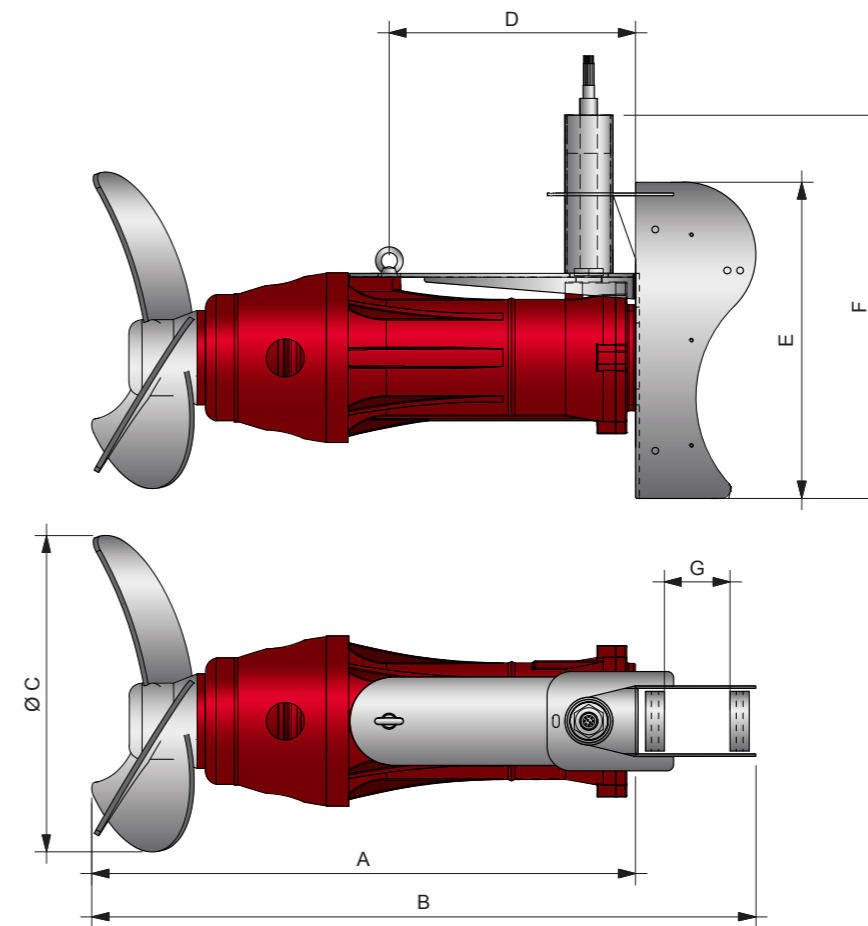

CARATTERISTICHE TECNICHE _ TECHNICAL CHARACTERISTICS

TIPO TYPE	VELOCITÀ SPEED (50 Hz)	POTENZA NOMINALE P2 RATED POWER P2	POTENZA ASSORBITA P1 ABSORBED POWER P1	PESO WEIGHT	NUMERO PALE BLADE NUMBER	ELICA Ø PROPELLER Ø	CORRENTE NOMINALE RATED CURRENT	SPINTA DI REAZIONE REACTION THRUST
	giri/min r.p.m.	kW	kW	kg	-	mm	A (400 V)	N
MX-GIR 550.20	330	1,8	2,3	90	3	550	4,6	480
MX-GIR 550.30	330	3	3,4	131	3	550	7	620
MX-GIR 550.40	330	4,1	4,8	131	3	550	9	910
MX-GIR 550.55	322	5,5	6,3	139	3	550	12,5	1150
MX-GIR 550.75	351	7,5	8,3	185	3	550	15,5	1680
MX-GIR 550.90	351	9,2	10,4	190	3	550	19	1960
MX-GIR 550.110	351	11,1	12,3	195	3	550	24,5	2280
MX-GIR 720.150.4	351	15	17,4	199	2	720	30	2697
MX-GIR 770.185.4	354	18,5	20,7	204	2	780	36	3826

DIMENSIONI _ DIMENSIONS

TIPO TYPE	A	B	C	D	E	F	G
	mm	mm	mm	mm	mm	mm	mm
MX-GIR 550.20	761	885	550	332	300	-	60x60*
MX-GIR 550.30	860	1050	550	390	500	605	100x100**
MX-GIR 550.40	860	1050	550	390	500	605	100x100**
MX-GIR 550.55	860	1050	550	390	500	605	100x100**
MX-GIR 550.75	919	1109	550	386	500	605	100x100**
MX-GIR 550.90	919	1109	550	386	500	605	100x100**
MX-GIR 550.110	919	1109	550	386	500	605	100x100**
MX-GIR 720.150.4	915	1185	720	385	550	-	100x100
MX-GIR 770.185.4	922	1192	780	385	550	-	100x100

* adattabile a 50x50 • adaptable to 50x50
** adattabile a 80x80 • adaptable to 80x80



GALLERY

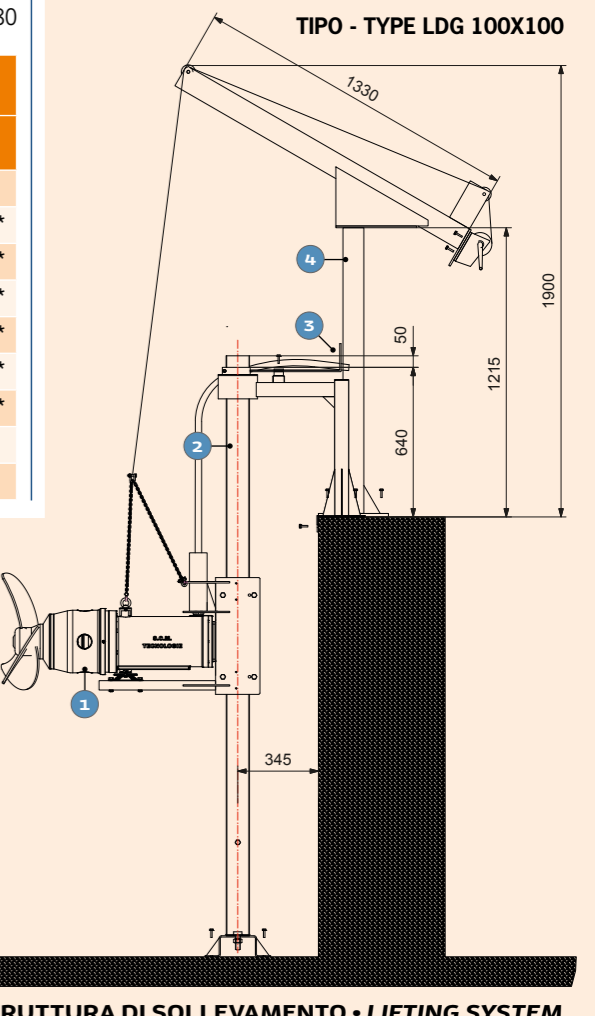
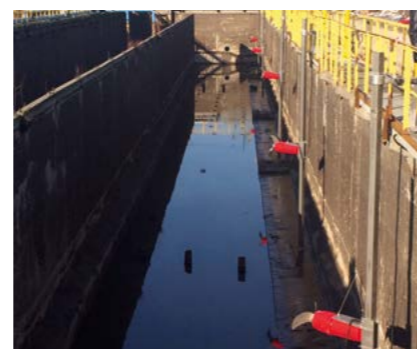

TIPO - TYPE LDV 60X60
MIXER 1
palo guida mixer • mixer's guide rail 2
staffa orientamento mixer • mixer's directional bracket 3
struttura di sollevamento mixer in acciaio inox AISI 304 4
mixer's lifting system in stainless steel AISI 304 4

TIPO - TYPE LDG 100X100
MIXER 1
palo guida mixer • mixer's guide rail 2
staffa orientamento mixer • mixer's directional bracket 3
struttura di sollevamento mixer in acciaio zincato 4
mixer's lifting system in galvanised steel 4

STRUTTURA DI SOLLEVAMENTO • LIFTING SYSTEM



WASTEWATER TREATMENT AERATION AND MIXING

S.C.M. TECNOLOGIE s.r.l.

via Einstein 6/A | 46051 San Giorgio Bigarello (MN) Italy

T. +39 0376 321936 | **F. +39 0376 364472** | info@scmtec.com



www.scmtec.com

La nostra ditta persegue una politica di costante miglioramento del prodotto, pertanto i valori delle tabelle non sono vincolanti e ci riserviamo il diritto di apportare modifiche alle macchine senza preavviso.

The policy of our firm is in constant improvement, therefore the values indicated in the diagrams are not fixed and can be changed.