

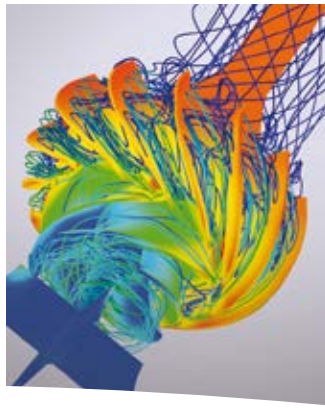

***SIHI® SuperNova  
Modular Industrial Pumps***



*Experience In Motion*



## ***Pump Supplier to the World***

*Flowserve is the driving force in the global industrial pump marketplace. No other pump company in the world has the depth or breadth of expertise in the successful application of pre-engineered, engineered, and special purpose pumps and systems.*

### ***Life Cycle Cost Solutions***

Flowserve provides pumping solutions that permit customers to reduce total life cycle costs and improve productivity, profitability and pumping system reliability.

### ***Market-Focused Customer Support***

Product and industry specialists develop effective proposals and solutions directed toward market and customer preferences. They offer technical advice and assistance throughout each stage of the product life cycle, beginning with the initial inquiry.

### ***Broad Product Lines***

Flowserve offers a wide range of complementary pump types, from pre-engineered process pumps to highly engineered and special purpose pumps and systems. Pumps are built to recognized global standards and customer specifications.

Pump designs include:

- Single-stage process
- Between bearings single-stage
- Between bearings multistage
- Vertical
- Submersible motor
- Positive displacement
- Vacuum & Compressor
- Nuclear
- Specialty

### ***Product Brands of Distinction***

*ACEC™ Centrifugal Pumps*

*Aldrich™ Pumps*

*Byron Jackson® Pumps*

*Calder™ Energy Recovery Devices*

*Cameron™ Pumps*

*Durco® Process Pumps*

*Flowserve® Pumps*

*IDP® Pumps*

*INNOMAG® Sealless Pumps*

*Lawrence Pumps®*

*Niigata Worthington™ Pumps*

*Pacific® Pumps*

*Pleuger® Pumps*

*Scienco™ Pumps*

*Sier-Bath® Rotary Pumps*

*SIHI® Pumps*

*TKL™ Pumps*

*United Centrifugal® Pumps*

*Western Land Roller™ Irrigation Pumps*

*Wilson-Snyder® Pumps*

*Worthington® Pumps*

*Worthington Simpson™ Pumps*

### Typical Applications

- Cooling
- Heating
- Irrigation
- Water supply
- Solvent transfer
- Acid & Alkali transfer
- Effluent
- Filter cleaning
- Deluge
- Pressure boosting



## SIHI® SuperNova – Robust, Reliable, Efficient ...

Broad application suitability underpins the SIHI® SuperNova range of end-suction centrifugal pumps. Demanding temperature profile, hydraulic efficiency, low NPSH make this range a perfect choice for those making an ecologically balanced decision. Designed with consideration of ISO 5199, assures long-term reliability, process consistency, and simple maintenance.

Three configurations of the SIHI® SuperNova range combine modularity with application fit. The general purpose end-suction design is complemented by two additional models for hot water and hot oil. All three designs are fundamentally different in which to match the different demands of each application.

Developed in accordance with some strict ISO, DIN, and EN standards guarantees the quality and market interchangeability of the SIHI® SuperNova. Highly effective seal chamber design is at the heart of this range, where seal face lubrication is of paramount importance for reliability.

Overhung single-stage impeller permits only one set of bearings, one seal configuration, one set of wear-rings, and back pull-out together with the other benefits of end-suction.

Multiple volutes with diffuser are employed in the larger machines in which to distribute radial forces, improve performance, and improve the life of the pump. Over 50 hydraulic sizes are available long or close-coupled, horizontal or vertical, in various materials, and with multiple sealing options.

### Industries/Markets

- Chemical
- Pharmaceutical
- Food
- Metal manufacture
- Rubber & Plastic
- Marine
- Paper & Pulp
- Tank Farm Storage
- Building services
- Textile

### Performance Range

- Capacity: max. 1800 m<sup>3</sup>/h (7926 Us gpm)<sup>1)</sup>
- Head: max. 140 m (459 ft)<sup>2)</sup>
- Speed: max. 3600 rpm
- Casing pressures: max. 40 bar (580 psi)
- Temperatures: max. + 350 °C (662 °F)<sup>3)</sup>

<sup>1)</sup> For higher capacities up to 2200 m<sup>3</sup>/h (9687 Us gpm) we recommend the SIHI® CBT range

<sup>2)</sup> For higher heads up to 1600 m (5249 ft) we recommend the SIHI® Multi range

<sup>3)</sup> For higher temperatures up to 400 °C (752 °F) we recommend the SIHI® ISOchem range

### Materials

- Cast iron
- SG iron
- Cast steel
- Stainless steel

### Sealing options

- Mechanical seal
- Gland packing
- Lip seals



General Purpose Pumps



**Horizontal End Suction Volute Casing Pumps** according to EN 733

170 °C  
338 °F

120 °C  
248 °F

ZLN long-coupled design with single or double mechanical seal, or packed gland. Optional possibilities include seal quench, cooling, heating, flushing, and throttling.

ZLK close-coupled design with single mechanical seal.

**In-Line Volute Casing Pumps** based on EN 733

120 °C  
248 °F

ZLI close-coupled design with single mechanical seal.

General Purpose Pumps	Capacity (maximum)	Head (maximum)	Speed (maximum)	Temperature (maximum)	Casing Pressure	Sealing	Materials
ZLN	1800 m <sup>3</sup> /h (7926 US gpm)	140 m (459 ft)	3600 rpm	170 °C (338 °F)	16 bar (232 psi)	Mechanical seal, gland packing	Cast iron, stainless steel
ZLK	740 m <sup>3</sup> /h (3258 US gpm)	90 m (295 ft)	3600 rpm	120 °C (248 °F)	16 bar (232 psi)	Mechanical seal	Cast iron, stainless steel
ZLI	280 m <sup>3</sup> /h (1233 US gpm)	60 m (197 ft)	3600 rpm	120 °C (248 °F)	16 bar (232 psi)	Mechanical seal	Cast iron, stainless steel

## Design Features

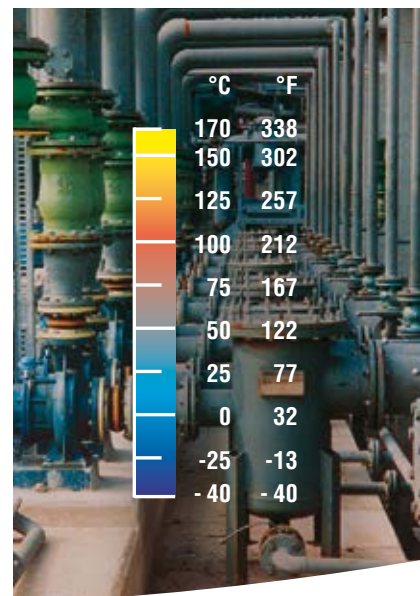
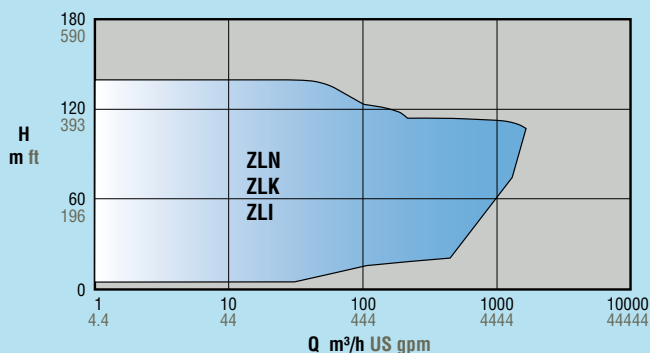

## ZLN

### Long lasting efficiency

- Closed impeller permitting 'neck' wear-rings to be retrofitted

Suitable for temperatures up to 170 °C (338 °F), this diverse range of general purpose pumps offers the user a low life-cycle cost solution. Capital cost, power consumption, maintenance, reliability, and waste, have all been considered during the extensive development phase.

### High efficiency & low power

- Advanced fluid dynamic design

### Low NPSH

- High quality impeller and suction profile

### Extended seal life

- Vortex breakers and modern seal chamber
- Low shaft deflection

### Flexible sealing options

- Single or double mechanical seals
- Cartridge or component seals
- Packed gland

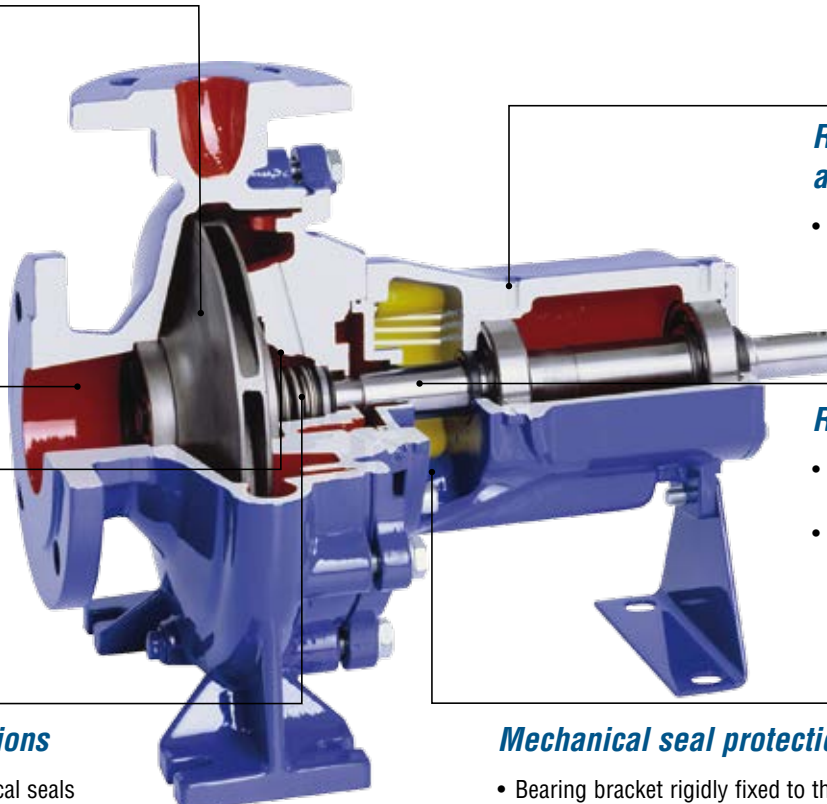

### Robust rotating assembly

- Oversized ball bearings and shaft diameter

### Reliability

- Seal area shaft deflection to ISO 5199
- General consideration of ISO 5199

### Mechanical seal protection

- Bearing bracket rigidly fixed to the casing cover for stable back pull-out transportation

Hot Water Pumps  
up to 230 °C  
(446 °F)



## Horizontal End Suction Volute Casing Pumps

according to EN 733 or EN 22858

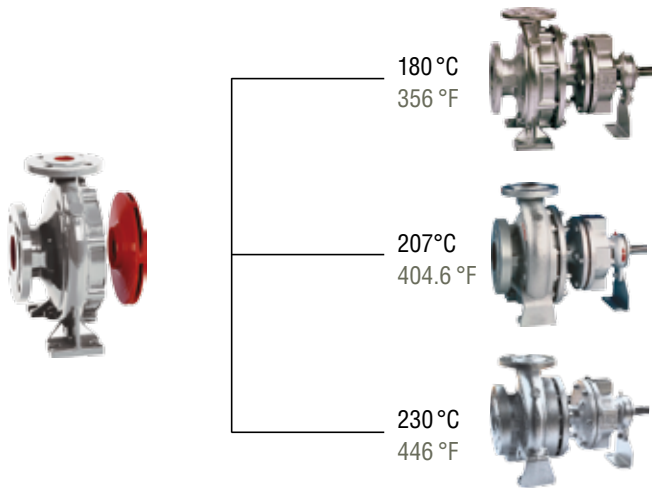

**ZHN** long-coupled. Designed specifically for use with pressurised high-temperature water without the need to cool the single mechanical seal. Main dimensions in accordance with EN 733.

**ZDN** long-coupled. Designed specifically for use with pressurised high-temperature water without the need to cool the single mechanical seal. Main dimensions in accordance with EN 22858.

**ZEN** long-coupled. Designed specifically for use with pressurised high-temperature water without the need to cool the single mechanical seal. Main dimensions in accordance with EN 22858.

## In-Line Volute Casing Pumps based on EN 733

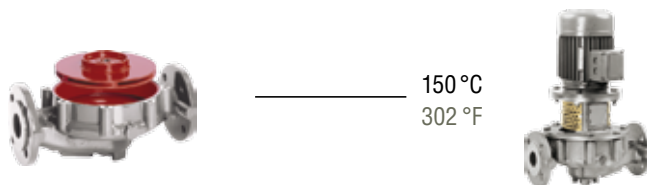

**ZDI** close-coupled design with single mechanical seal that does not need to be cooled.

Hot Water Pumps	Capacity (maximum)	Head (maximum)	Speed (maximum)	Temperature (maximum)	Casing Pressure	Sealing	Materials
ZHN	600 m <sup>3</sup> /h (2642 US gpm)	90 m (295 ft)	3600 rpm	180 °C (356 °F) un-cooled	16 bar (232 psi)	Mechanical seal	SG iron
ZDN	600 m <sup>3</sup> /h (2642 US gpm)	90 m (295 ft)	3600 rpm	207 °C (404 °F) un-cooled	25 bar (362 psi)	Mechanical seal	SG iron
ZEN	600 m <sup>3</sup> /h (2642 US gpm)	90 m (295 ft)	3600 rpm	230 °C (446 °F) un-cooled	40 bar (580 psi)	Mechanical seal	SG iron, cast steel
ZDI	140 m <sup>3</sup> /h (616 US gpm)	60 m (196 ft)	3600 rpm	150 °C (302 °F) un-cooled	25 bar (362 psi)	Mechanical seal	SG iron

**Design Features**

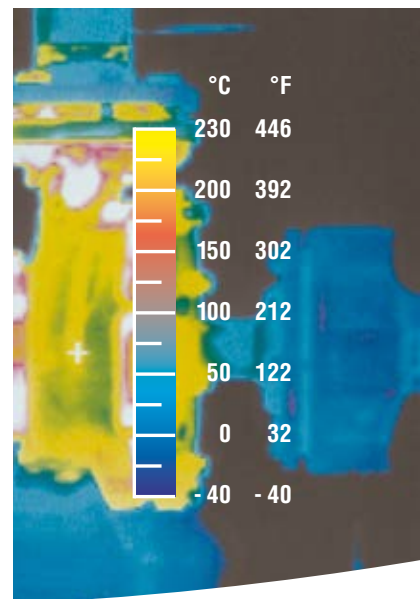
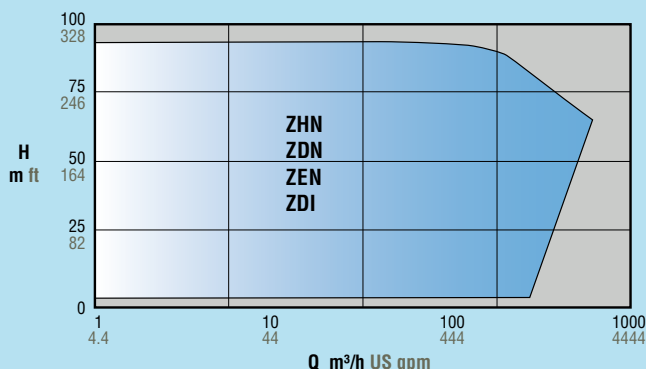

**ZHN**

**Long lasting efficiency**

- Closed impeller permitting ‘neck’ wear-rings to be retrofitted

Superior hot water circulation, up to 230 °C (446 °F) with a standard un-cooled mechanical seal, gives the unique ability to minimise life-cycle cost. Internal separation and removal of undesirable vapour (steam) enhances mechanical seal face lubrication and improves reliability. High-level hydraulic efficiency ensures that running costs are predictably low.

**High efficiency & low power**

- Advanced fluid dynamic design

**Low NPSH**

- High quality impeller and suction profile

**Simple removal**

- Back pull-out design

**Un-cooled seal**

- Vapour separation and removal in this unique seal chamber
- Large volume seal chamber located at cool drive-end
- Low shaft deflection

**Long life**

- Anti-friction bearing

**Robust rotating assembly**

- Long-life ball bearing
- Sleeve bearing

**Reduced spare parts cost**

- Standard mechanical seal to DIN 24960

**Stable with temperature fluctuations**

- Provision for thermal expansion

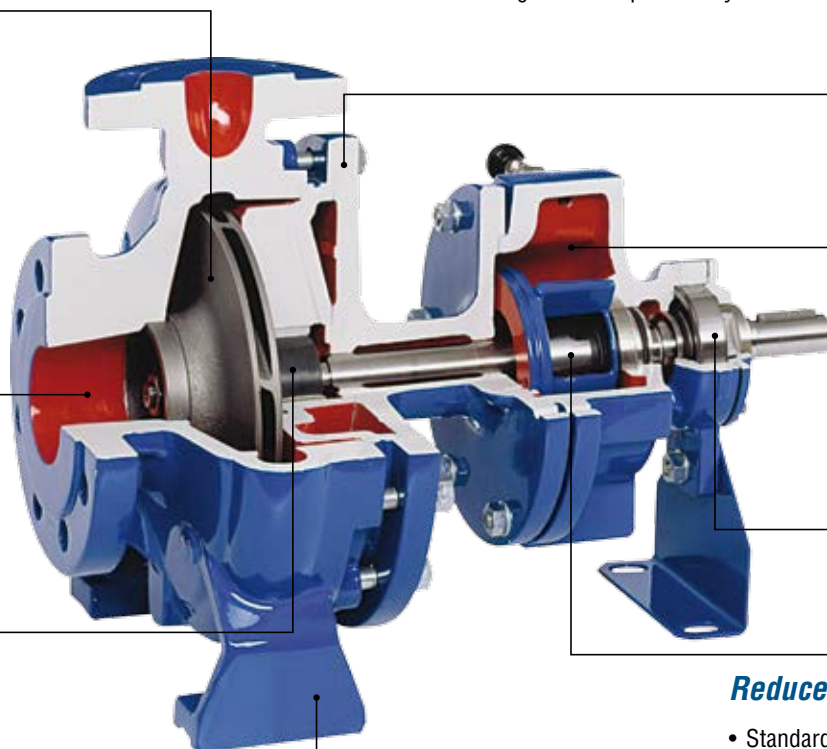



**Thermal Oil Pumps  
up to 350 °C  
(662 °F)**



## **Horizontal End Suction Volute Casing Pumps** according to EN 733

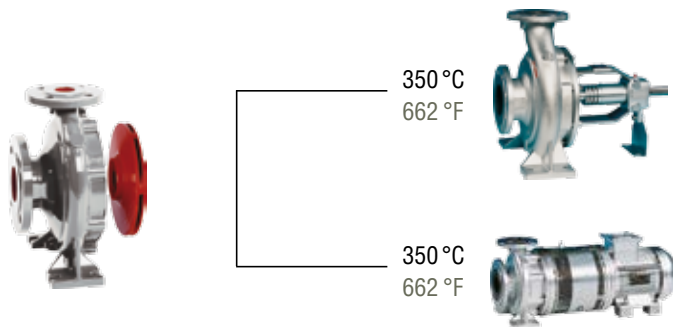

350 °C  
662 °F

350 °C  
662 °F

ZTN long-coupled. With auxiliary seal security, these units are designed specifically for use with high-temperature thermal oils. Main dimensions in accordance with EN 733.

ZTK close-coupled. The addition of a shaft mounted air-cooling fan, together with the auxiliary seal security, makes the ZTK a perfect solution for high-temperature thermal oils. Main dimensions in accordance with EN 733.

## **In-Line Volute Casing Pumps** based on EN 733

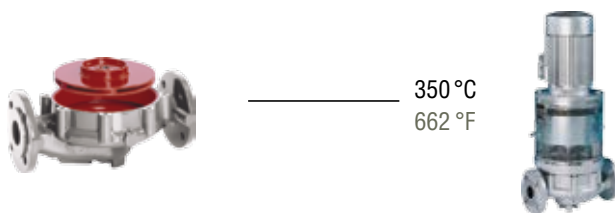

350 °C  
662 °F

ZTI close-coupled. The addition of a shaft-mounted air-cooling fan, together with the auxiliary sealing options, makes the ZTI an ideal selection for high-temperature thermal oils where space is at a premium.

Thermal Oil Pumps	Capacity (maximum)	Head (maximum)	Speed (maximum)	Temperature (maximum)	Casing (maximum)	Sealing Pressure	Materials
ZTN	1000 m <sup>3</sup> /h (4403 US gpm)	90 m (295 ft)	3600 rpm	350 °C (662 °F) un-cooled	16 bar (232 psi)	Mechanical seal, lip seals	SG iron
ZTK	200 m <sup>3</sup> /h (880 US gpm)	60 m (196 ft)	3600 rpm	350 °C (662 °F) un-cooled	16 bar (232 psi)	Mechanical seal	SG iron
ZTI	200 m <sup>3</sup> /h (880 US gpm)	60 m (196 ft)	3600 rpm	350 °C (662 °F) un-cooled	16 bar (232 psi)	Mechanical seal	SG iron



**Design Features**

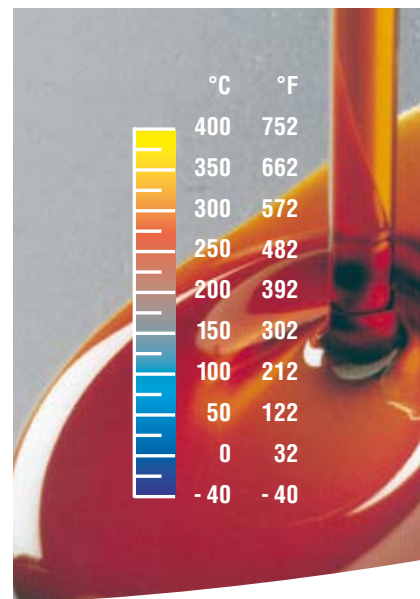
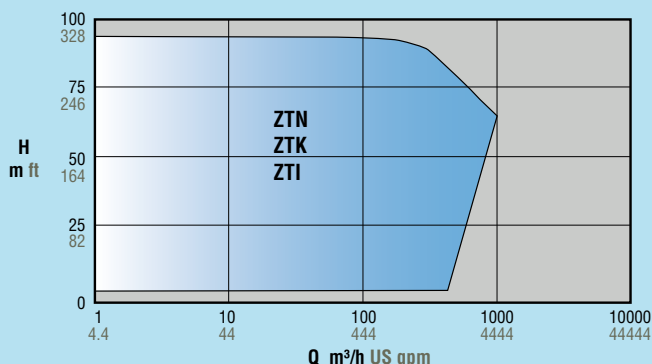

**ZTN**

**Long lasting efficiency**

- Closed impeller permitting ‘neck’ wear-rings to be retrofitted

**High efficiency & low power**

- Advanced fluid dynamic design

**Low NPSH**

- High quality impeller and suction profile

**Robust rotating assembly**

- Long-life ball bearing
- Sleeve bearing

Operational safety, environmental concern, and long-term reliability, are the three aspects which make this pump an ideal choice for thermal oils up to 350 °C (662 °F). High-end hydraulic efficiency is complimented by almost maintenance-free operation, in which to give a low Life-Cycle cost solution. Shaft sealing can be either a combination of mechanical and secondary lip seals, or seal-less magnetic drive for 400 °C (752 °F) oils.

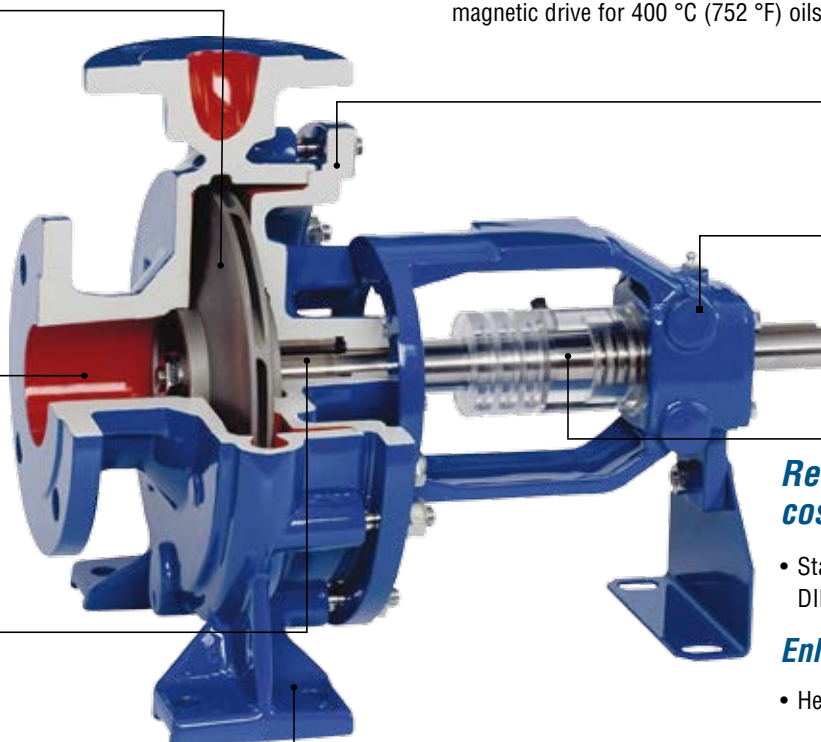

**Simple removal**

- Back pull-out design

**Triple protection**

- Mechanical seal backed by lip seals and bearing assembly

**Reduced spare parts cost**

- Standard mechanical seal to DIN 24960 and basic lip seals

**Enhanced seal life**

- Heat dissipation with air-fin cooling

**Stable with temperature fluctuations**

- Provision for thermal expansion

### Features

- High efficiency
- Seal area deflection to ISO 5199
- Low NPSH
- Modular family
- Back pull-out
- Global service network
- ATEX



### Benefits

- Reduced power consumption
- High reliability & extended MTBF
- Reduced installation costs
- Low inventories, short deliv times
- Ease of maintenance
- Local and rapid support
- Suitable for explosive atmospheres

### Horizontal End Suction Volute Casing Pumps

according to EN 733



### General Purpose Pumps



ZLN long-coupled design  
up to 170 °C (338 °F)



ZLK close-coupled design  
up to 120 °C (248 °F)

### Hot Water Pumps



ZHN long-coupled design  
up to 180 °C (356 °F)



ZDN long-coupled design  
up to 207 °C (404.6 °F)



ZEN long-coupled design  
up to 230 °C (446 °F)

### Thermal Oil Pumps

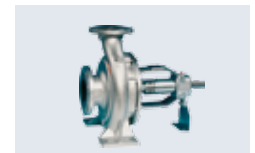

ZTN long-coupled design  
up to 350 °C (662 °F)



ZTK close-coupled design  
up to 350 °C (662 °F)

### In-Line Volute Casing Pumps

based on EN 733

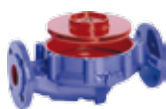

### General Purpose Pumps



ZLI close-coupled design  
up to 120 °C (248 °F)

### Hot Water Pumps



ZDI close-coupled design  
up to 150 °C (302 °F)

### Thermal Oil Pumps



ZTI close-coupled design  
up to 350 °C (662 °F)

**Global Service  
and Technical  
Support**



## Life Cycle Cost Solutions

Typically, 90 % of the total life cycle cost (LCC) of a pumping system is accumulated after the equipment is purchased and installed. Flowserve has developed a comprehensive suite of solutions aimed at providing customers with unprecedented value and cost savings throughout the life span of the pumping system. These solutions account for every facet of life cycle cost, including:

### Capital Expenses

- Initial purchase
- Installation

### Operating Expenses

- Energy consumption
- Maintenance
- Production losses
- Environmental
- Inventory
- Operating
- Removal

### Innovative Life Cycle Cost Solutions

- New Pump Selection
- Turnkey Engineering and Field Service
- Energy Management
- Pump Availability
- Proactive Maintenance
- Inventory Management

### Typical Pump Life Cycle Costs<sup>1</sup>

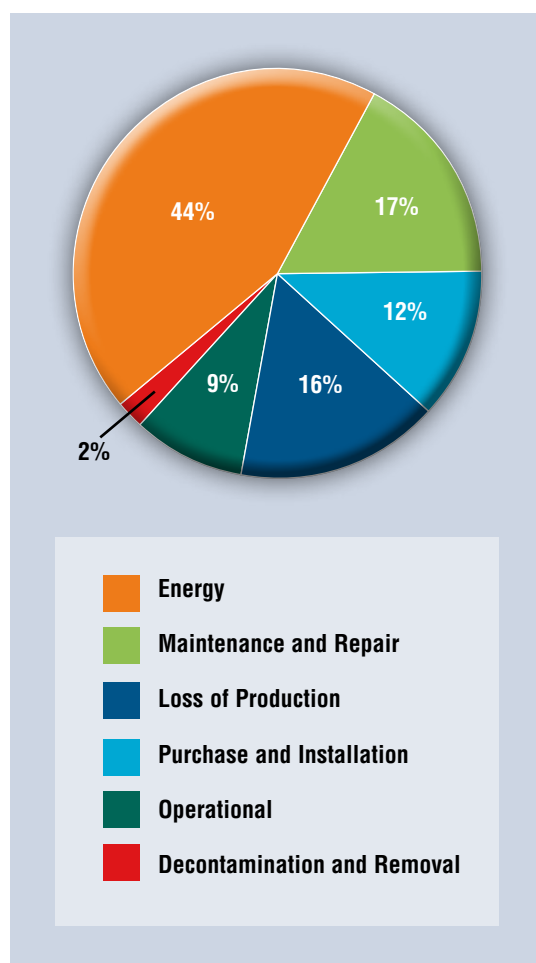

<sup>1</sup> While exact values may differ, these percentages are consistent with those published by leading pump manufacturers and end users, as well as industry associations and government agencies worldwide.



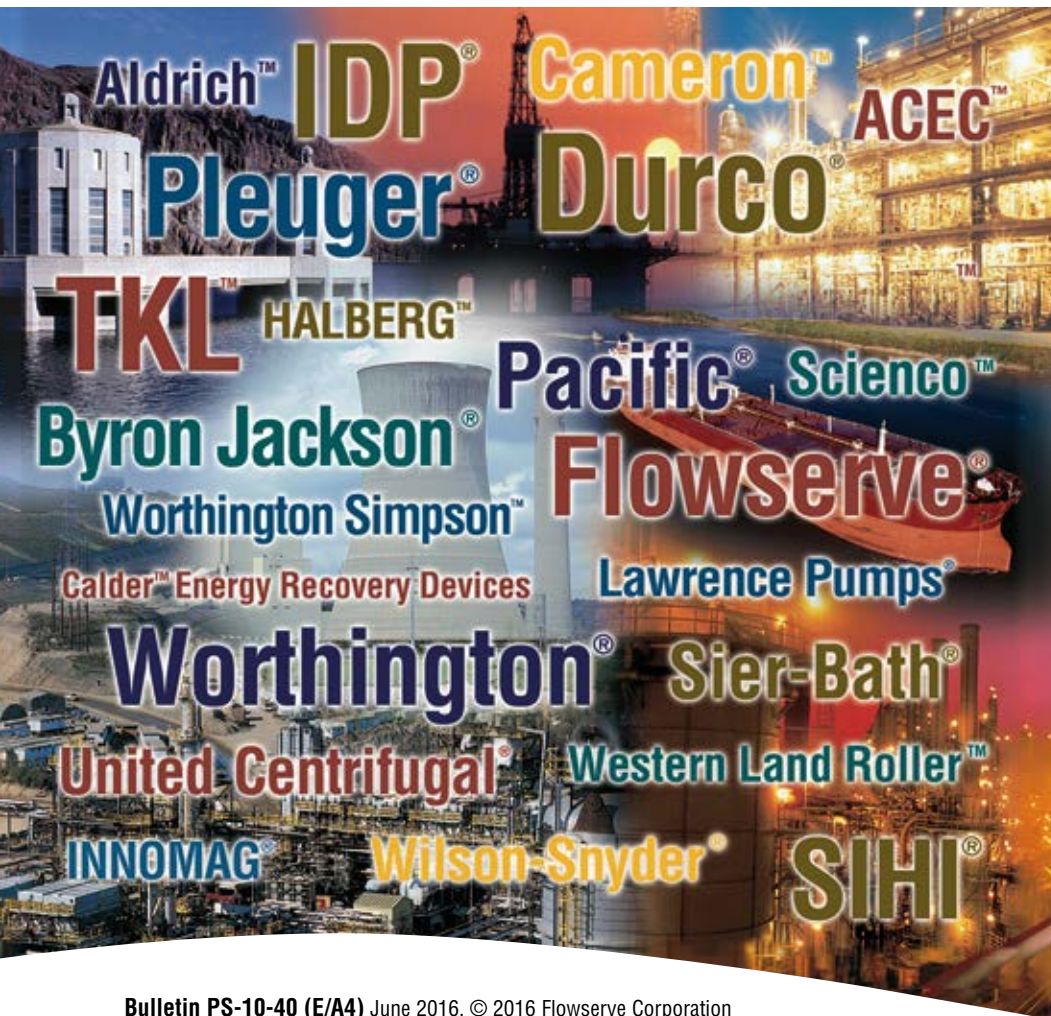

Bulletin PS-10-40 (E/A4) June 2016. © 2016 Flowserve Corporation

***To find your local Flowserve representative:***

For more information about Flowserve Corporation, visit [www.flowserve.com](http://www.flowserve.com) or call +1 937 890 5839.

**USA and Canada**

Flowserve Corporation  
5215 North O'Connor Blvd.  
Suite 2300  
Irving, Texas 75039-5421 USA  
Telephone: +1 937 890 5839

**Europe, Middle East, Africa**

Flowserve Corporation  
Parallelweg 13  
4878 AH Etten-Leur  
The Netherlands  
Telephone: +31 76 502 8100

**Latin America**

Flowserve Corporation  
Martín Rodríguez 4460  
B1644CGN-Victoria-San Fernando  
Buenos Aires, Argentina  
Telephone: +54 11 4006 8700  
Telefax: +54 11 4714 1610

**Asia Pacific**

Flowserve Pte. Ltd.  
10 Tuas Loop  
Singapore 637345  
Telephone: +65 6771 0600  
Telefax: +65 6862 2329