

# NETZSCH

Proven Excellence.

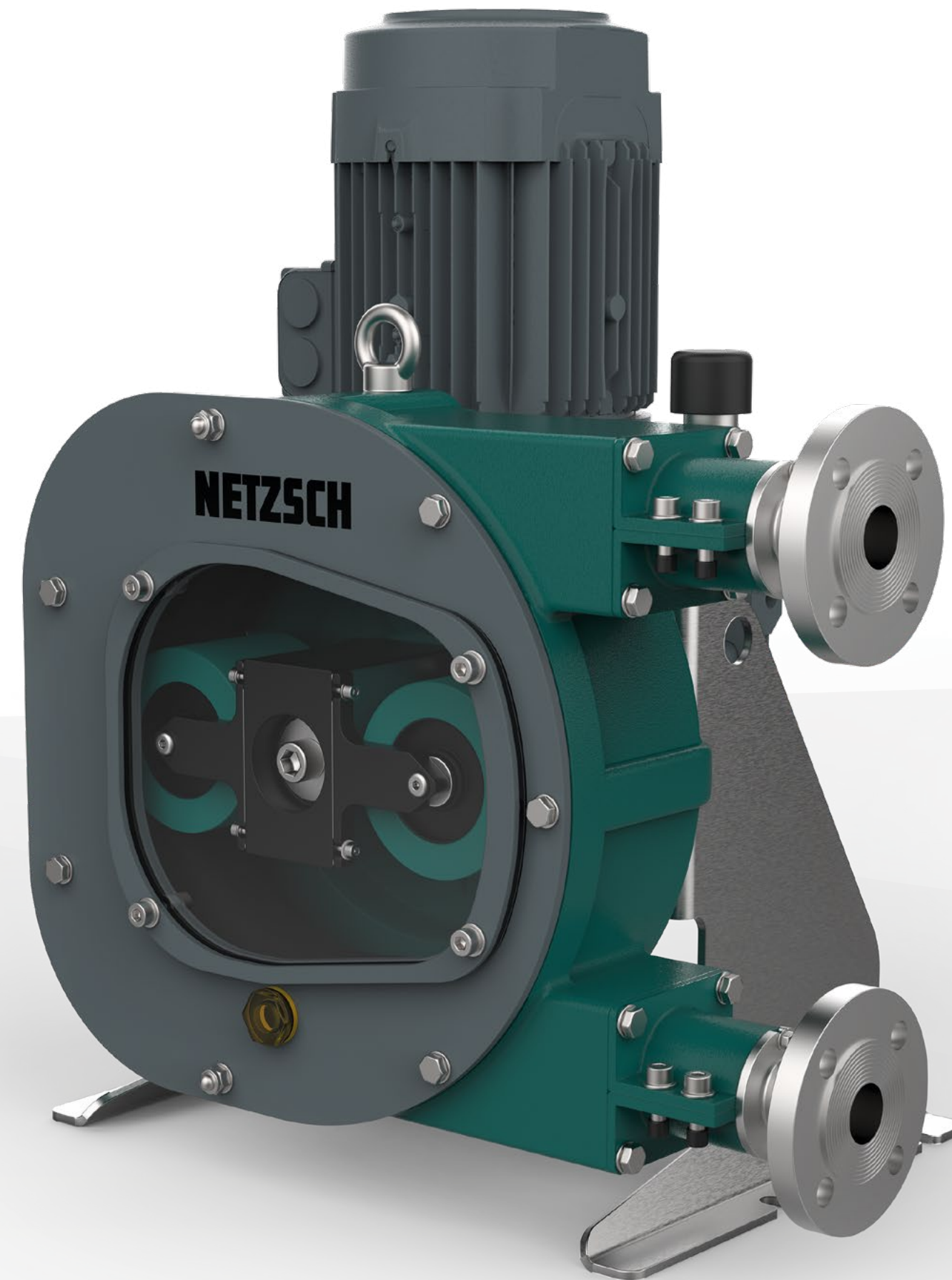

Products & Accessories

## PERIPRO<sup>®</sup> Peristaltic Pumps

Robust design for demanding applications

Pumps & Systems

# NETZSCH Pumps & Systems

YOUR GLOBAL SPECIALIST FOR CONVEYING COMPLEX MEDIA

NETZSCH Pumps & Systems, the global specialist for conveying complex media.

We promise you Proven Excellence - outstanding performance in all areas.

Designed specifically for difficult conveying situations, the products range from very small industrial metering pumps to high volume pumps for applications in the oil and gas sector or the mining industry. Our **NEMO® progressing cavity pumps**, **TORNADO® rotary lobe pumps**, **NOTOS® multi screw pumps**, **PERIPRO® peristaltic pumps**, **grinders**, **dosing equipment** and **accessories** offer customised, reliable solutions for your applications all over the world.

The high level of quality of our products and original spare parts is based on over 70 years of experience in development, production and distribution. We manufacture more than 75,000 pumps per year, which works to your benefit as our customer: The high level of reliability allows you to reduce your maintenance costs and take preventive action against unplanned downtime.

Our service and support does not end with the purchase. On the contrary – it starts well before an order is placed. From consultation, maintenance and spare parts to repairs and modernisation of your pump, we support you from the outset. And with our worldwide service network, we are here to help around the clock in the event of an emergency.

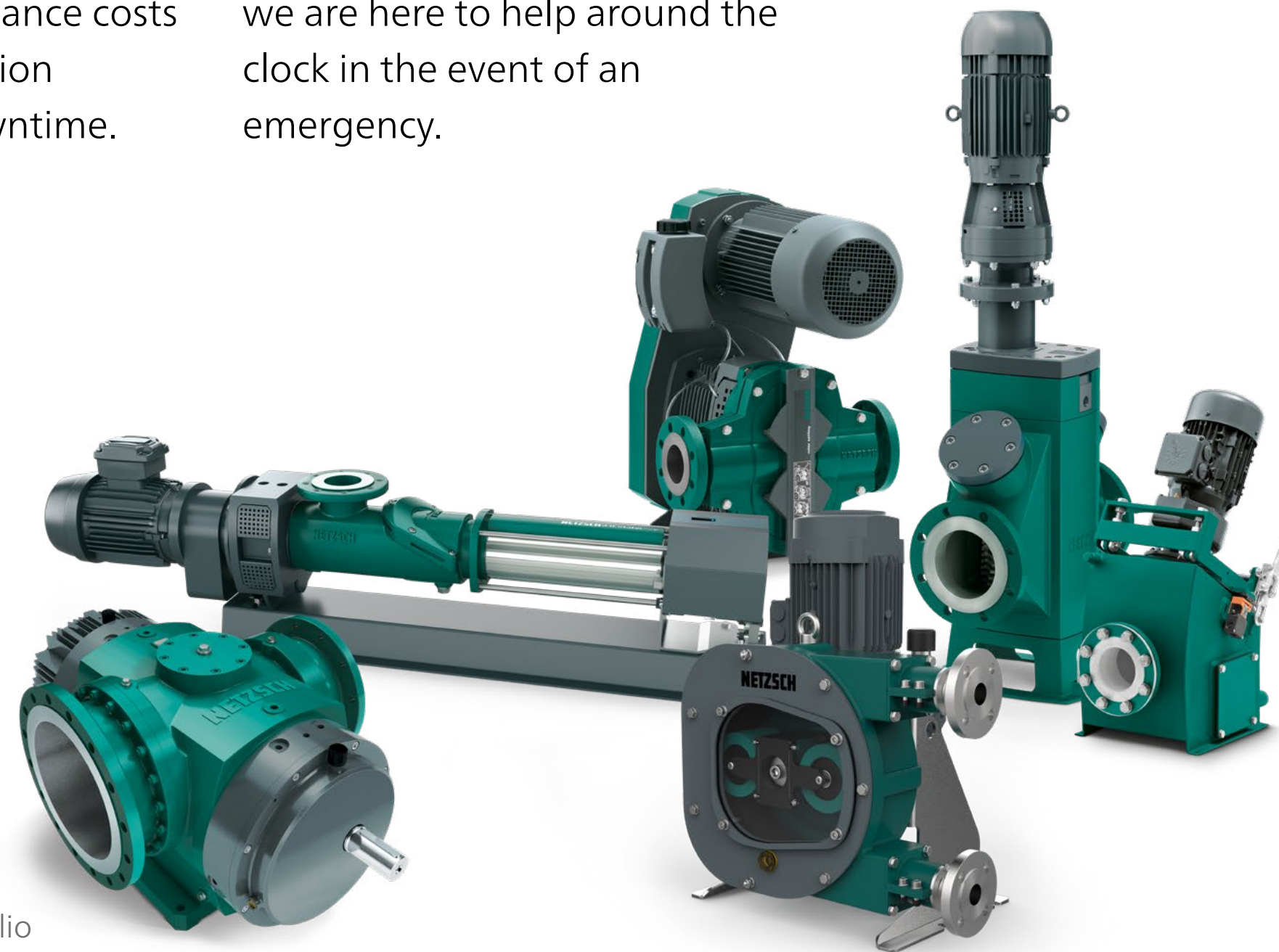

The NETZSCH product portfolio

**All NETZSCH pumps can be used in a wide range of applications, for example:**

- Bonding and sealing
- Chemicals
- Dosing
- Environmental technology
- Food and beverages
- Marine applications
- Mining
- Oil & gas production and transfer
- Paints and coatings
- Paper industry
- Pharmaceuticals and cosmetics
- Renewable energies
- Water and wastewater treatment



# PERIPRO® Pumps

HIGH PERFORMANCE PERISTALTIC PUMPS WITH LARGE ROLLERS FOR A LONGER SERVICE LIFE

## NETZSCH technology for peristaltic pumps

- Excellent abrasion resistance
- Extremely high suction capability
- No valves or mechanical seals
- Industrial, corrosion resistant and food safe models
- Dosing accuracy:  $\pm 1\%$
- Up to 70 % solids content in the conveyed media

## Advantages of PERIPRO® pumps

- Very long pump service life and excellent performance
- Robust pump technology
- Easy hose replacement
- Low starting torque
- High resistance to dry running
- Lower energy costs
- Low lubricant requirement

## Ideal for difficult media

- Abrasive media: lime milk, activated carbon, slurries, etc.
- Corrosive media: sodium hypochlorite, ferric chloride, hydrochloric acid, etc.
- Viscous media: adhesives, greases, creams, resins, etc. (water based)
- Delicate media: latex, polymers, flocculants, food, etc.

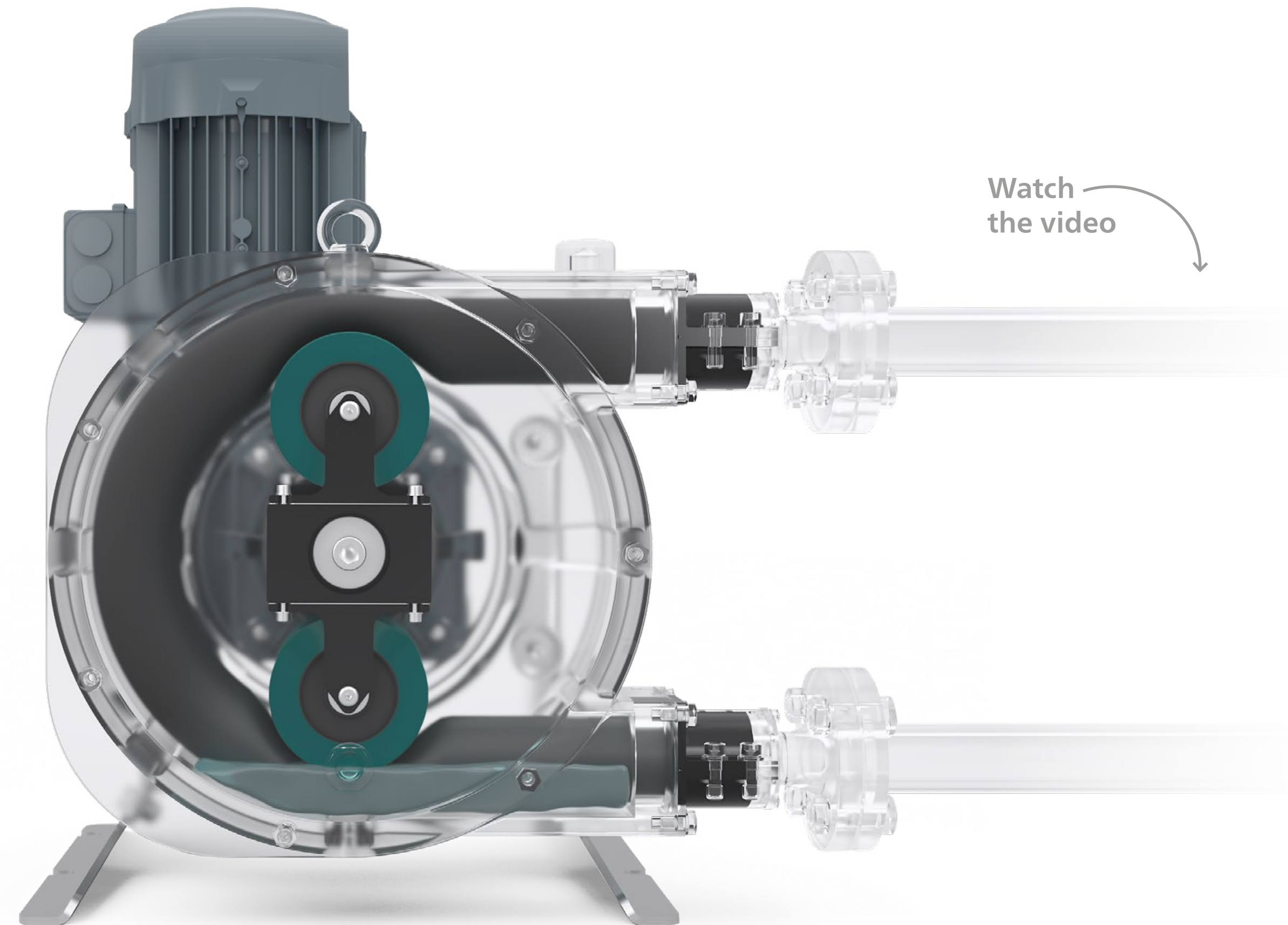

Watch  
the video

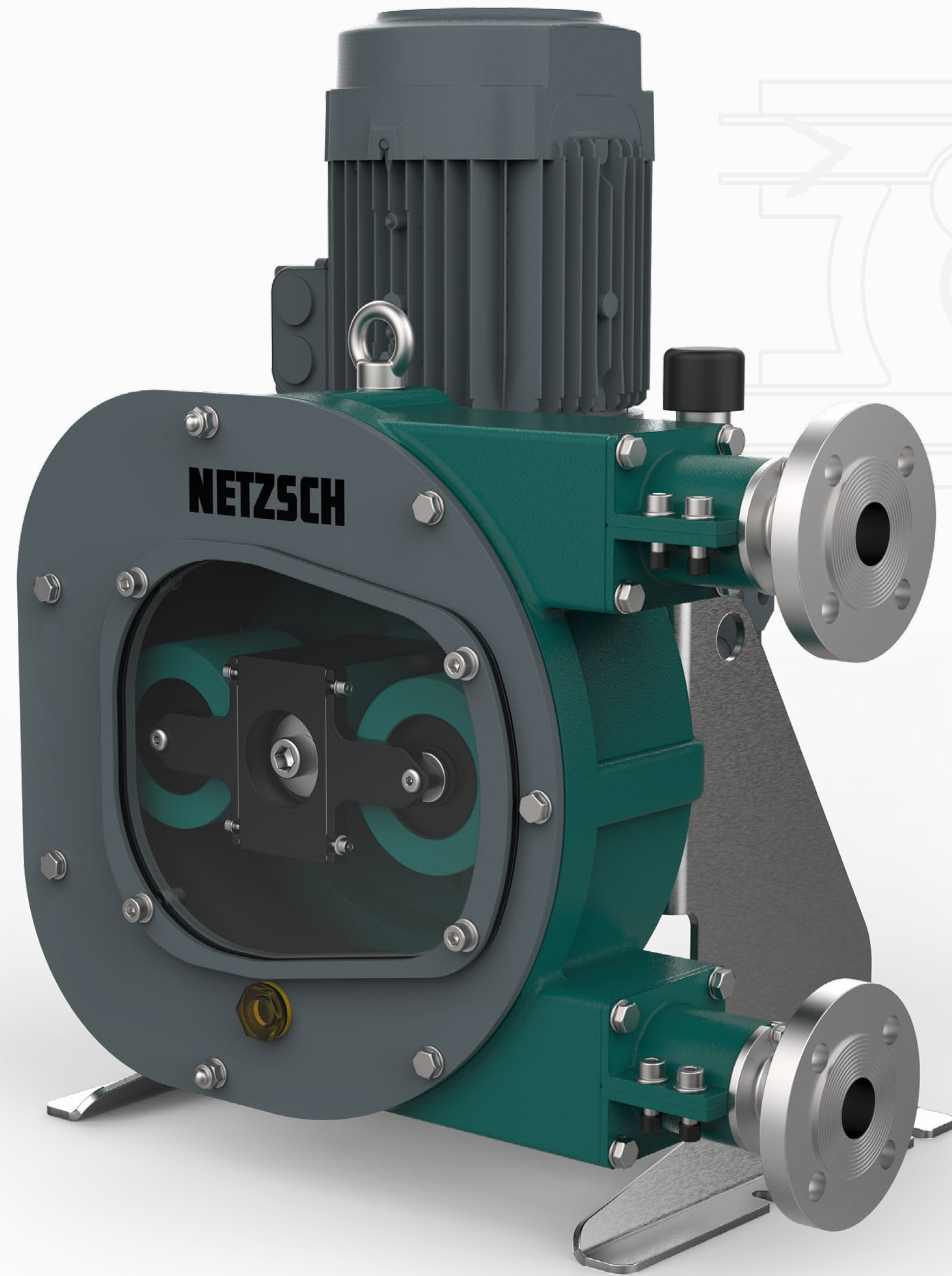

- ★ Up to 30 % energy savings
- ★ Highly robust design with XXL rollers
- ★ 90 % less lubricant
- ★ Only one wear part

# The PERIPRO® Design

## WHAT MAKES THIS PUMP SO DURABLE?

1

### Low hose wear

High quality hose with unique manufacturing process. Extruded inner layer, highly compacted textile reinforcement and precision manufactured outer layer. Available materials that are compatible with all types of products and working conditions.

2

### Robust design

Fast and easy installation, commissioning and maintenance. Innovative pump design that facilitates installation and hose replacement. Maintenance free pump and up to 90% less lubricant consumption compared to conventional pumps.

3

### Bearings

Integrated oversized bearings to resist the axial loads. Reliable connection system and highly robust materials.

4

### Rollers

Excellent compression of the hose without friction. Up to 30% lower energy consumption and longer hose service life due to the roller size. Easier operation with minimum starting torque and a very wide frequency range.

☆

**In summary: PERIPRO® pumps are easy to operate while offering excellent energy savings, a longer service life and greater durability of the hose.**

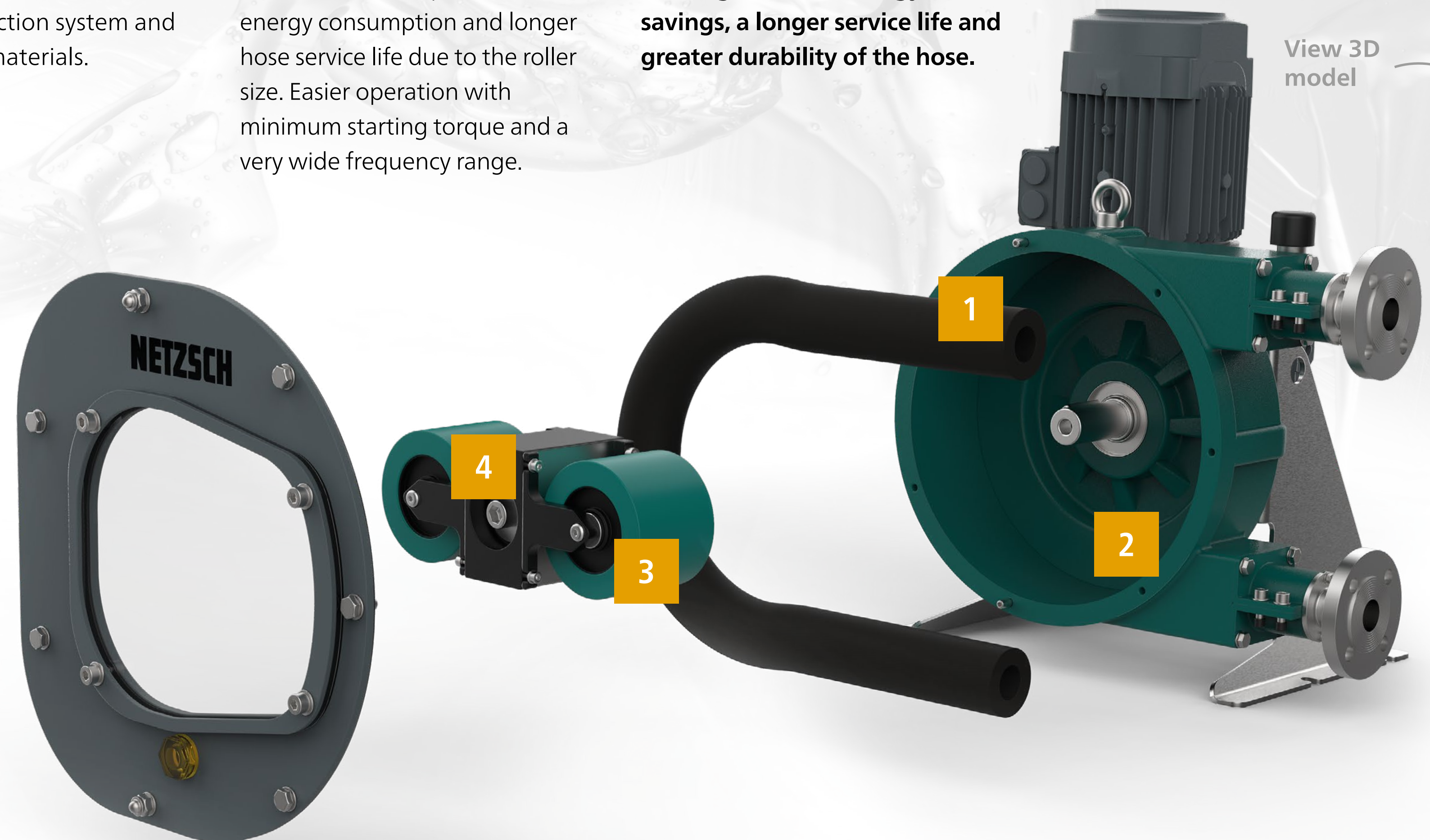

# The Three Versions

TO SUIT YOUR APPLICATION



## Industrial version

Robust design for conveying abrasive and aggressive media



- High durability and maximum serviceability
- Robust design
- Service-friendly conveying of abrasive and aggressive media like ceramic slip or mortar



## Food version

Contamination free conveying of food and particularly easy cleaning

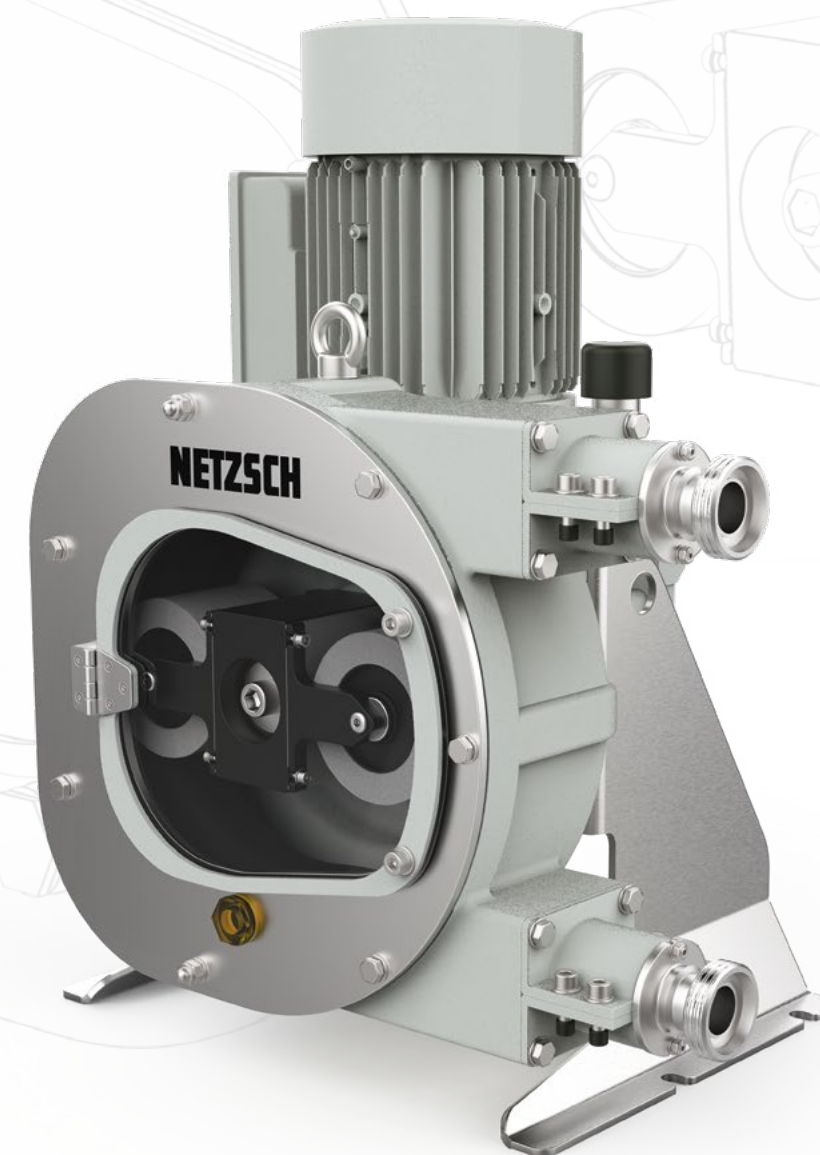

- The hatch in the cover allows for removal of the rollers and even easier cleaning of the pump
- Hose made of food grade FDA-certified nitrile
- Typical applications: transfer of viscous sauces and juices or supplying of filling machines



## Chemical version

High level of reliability for conveying and dosing corrosive media



- Sensor for hose leakage
- Only one part in contact with the medium, chemically resistant TEFZEL® coated housing
- Transferring and dosing of highly abrasive media like titanium dioxide or resins

# Service and Support

FOR US, PARTNERSHIP DOES NOT END WITH THE PURCHASE.

**We know no limits when it comes to offering our customers first rate service. Our promise is to deliver Proven Excellence – outstanding performance in all areas.**



## **Unlimited personal support**

Our experienced employees provide support and advice worldwide and around the clock, always tailored to your specific requirements. With our global network of service locations and warehouses, we guarantee prompt and efficient support, including on site and in person, so your pumps can always run smoothly.



## **Spare parts**

NETZSCH original spare parts stand for the highest manufacturing quality. We ensure reliable quality through worldwide implementation of uniform standards as per DIN EN ISO 9001. This enables reliable operation of your pumps with little downtime and low maintenance costs, and therefore continued optimum performance.



## **Technical training**

The specialists from our Technical Service provide practical training for your employees at the NETZSCH training centres, online or at your facility. This allows you to benefit from cost savings and increased pump efficiency and to avoid mistakes during commissioning, maintenance or repairs.

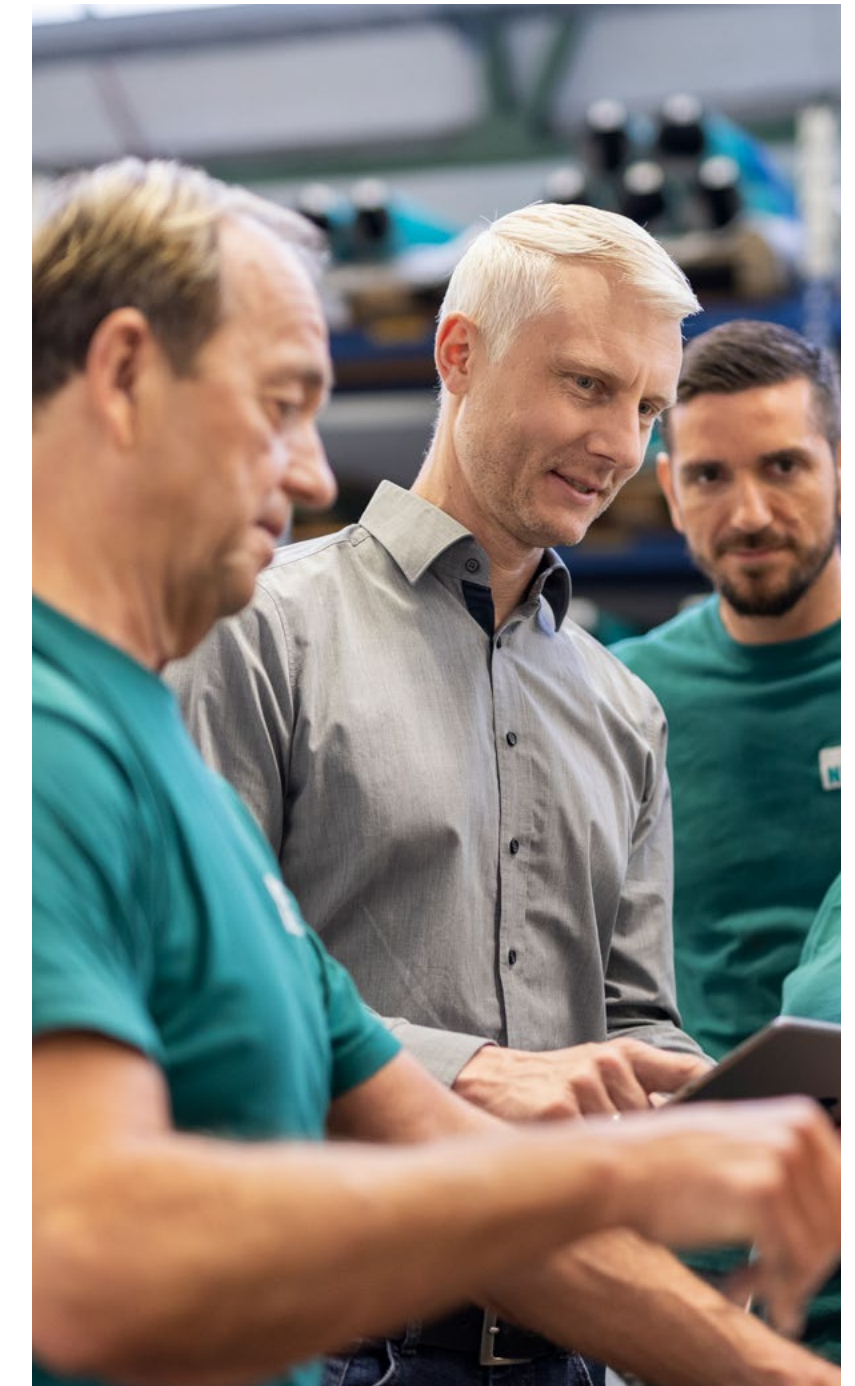

**More information on  
our service and support  
can be found here:**

The NETZSCH Group is an owner-managed, international technology company with headquarters in Germany. The Business Units Analyzing & Testing, Grinding & Dispersing and Pumps & Systems represent customized solutions at the highest level. A worldwide sales and service network ensure customer proximity and competent service.

Our performance standards are high. We promise our customers Proven Excellence – exceptional performance in everything we do, proven time and again since 1873.

The NETZSCH Business Unit Pumps & Systems offers NEMO® progressing cavity pumps, TORNADO® rotary lobe pumps, NOTOS® multi screw pumps, PERIPRO® peristaltic pumps, macerators/grinders, dosing technology and equipment that are custom built for challenging solutions for different applications globally.

# Proven Excellence. ■

NETZSCH Pumpen & Systeme GmbH  
Geretsrieder Straße 1  
84478 Waldkraiburg  
Germany  
Phone: +49 8638 63-0  
info.nps@netsch.com  
www.pumps-systems.netsch.com