

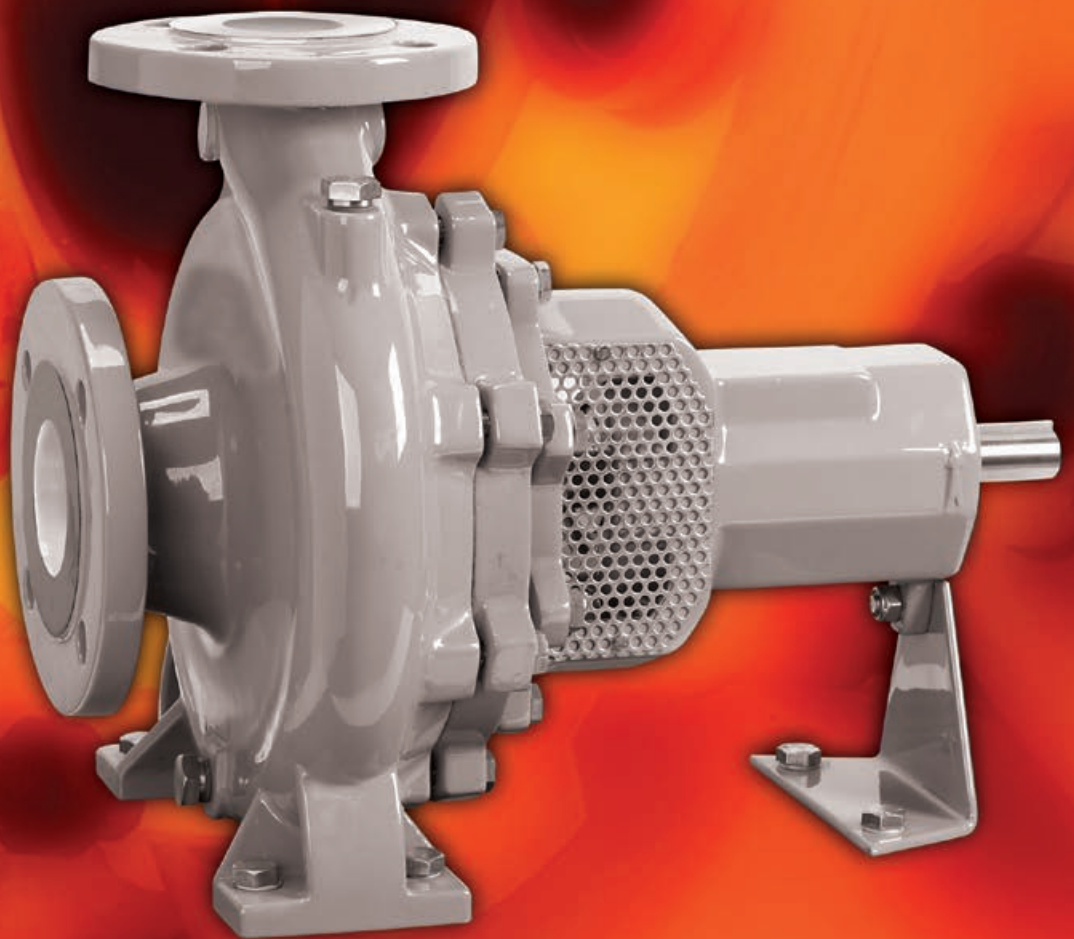

MEN Series

Single-Stage, End Suction Water Pumps

MEN – MENBLOC – ME



Experience In Motion

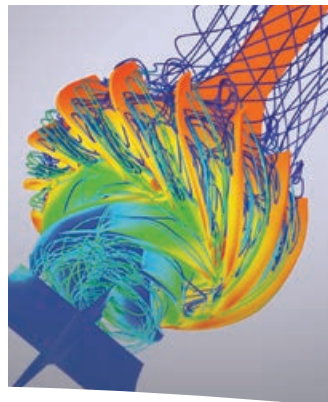

Pump Supplier to the World

Flowserve is the driving force in the global industrial pump marketplace. No other pump company in the world has the depth or breadth of expertise in the successful application of pre-engineered, engineered, and special purpose pumps and systems.

Life Cycle Cost Solutions

Flowserve provides pumping solutions that permit customers to reduce total life cycle costs and improve productivity, profitability and pumping system reliability.

Market-Focused Customer Support

Product and industry specialists develop effective proposals and solutions directed toward market and customer preferences. They offer technical advice and assistance throughout each stage of the product life cycle, beginning with the initial inquiry.

Broad Product Lines

Flowserve offers a wide range of complementary pump types, from pre-engineered process pumps to highly engineered and special purpose pumps and systems. Pumps are built to recognized global standards and customer specifications.

Pump designs include:

- Single-stage process
- Between bearings single-stage
- Between bearings multistage
- Vertical
- Submersible motor
- Positive displacement
- Nuclear
- Specialty

Product Brands of Distinction

ACEC™

Aldrich™

Byron Jackson®

Calder™ Energy Recovery Devices

Cameron™

Durco®

Flowserve®

HALBERG™

IDP®

INNOMAG®

Lawrence Pumps®

Niigata Worthington™

Pacific®

Pleuger®

Scienco™

Sier-Bath®

SIHI®

TKL™

United Centrifugal®

Western Land Roller™

Wilson-Snyder®

Worthington®

Worthington Simpson™

**MEN Series
Single-Stage,
End Suction
Water Pumps**

MEN
MENBLOC
ME

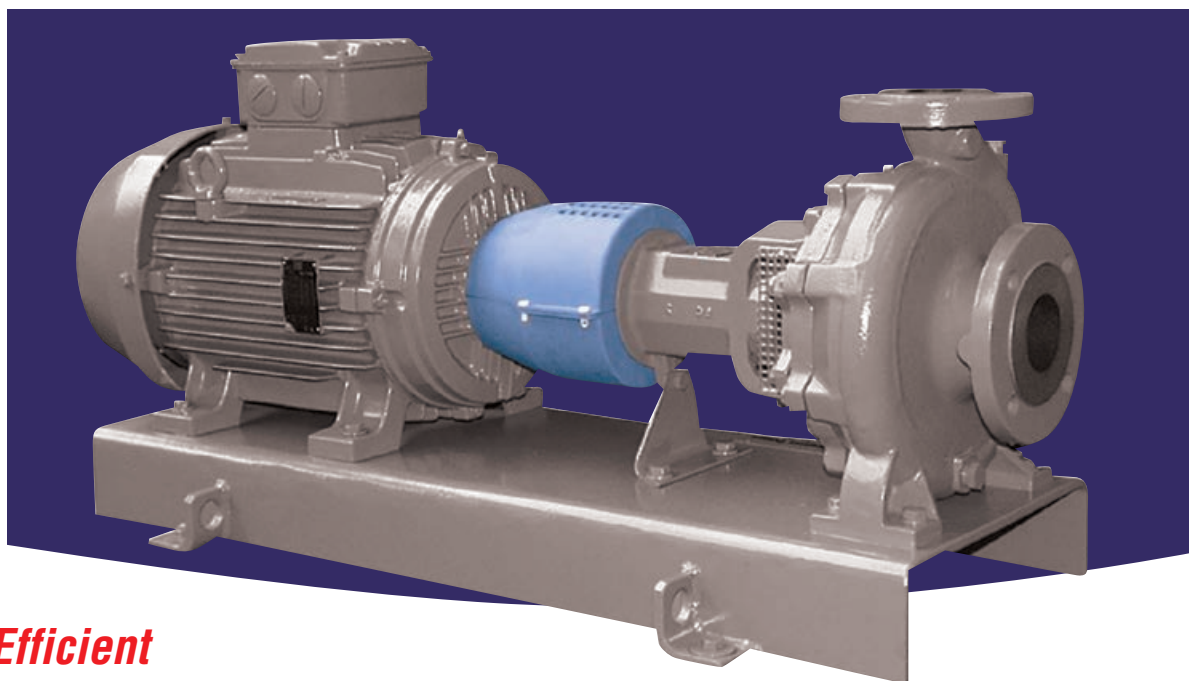

**Reliable and Efficient
Performance**

The MEN Series of single-stage, end suction water pumps provides broad hydraulic coverage with low total cost of ownership. MEN Series pumps feature optimized hydraulics and rugged construction to deliver long, reliable and efficient performance. Moreover, a high degree of parts interchangeability combined with low-maintenance designs make MEN Series pumps a “best value” selection for a wide variety of water, general and light chemical industry applications.

Three Models to Meet Varied Requirements

The MEN Series is comprised of three pump models to meet varied application requirements:

- **MEN**—Frame mounted with centerline discharge; high-capacity and high-pressure models available
- **MENBLOC**—Close coupled version of MEN
- **ME**—High-capacity, frame mounted with tangential discharge

Frame mounted models share a common bearing frame platform consisting of five sizes: 24, 32, 42, 55 and 70. This high degree of parts interchangeability helps to reduce inventory carrying costs and simplify maintenance.

Standards and Compliance

MEN Series pumps are CE marked and GOST certified. Compliance with applicable directives such as ATEX available.

European Regulation No. 547/2012

All MEN Series water pumps meet the eco-design requirements of European Regulation No. 547/2012. The optimized hydraulic design and high-quality components of MEN Series pumps ensure the mandated minimum efficiency index (MEI) of 0.4 is achieved. Energy consumption is also optimized by selecting the right impeller trim for the customer’s process needs.

Typical Applications

- Water supply
- Water treatment
- Irrigation
- Drainage
- Filter cleaning
- Fire protection
- General industry
- Water circulation
- HVAC
- Light chemical

Significant Benefits

MEN Series pumps are engineered to provide numerous significant benefits for users:

- **Superior performance**
 - Efficient operation
 - Low NPSHR
 - Quiet operation
- **Versatility**
 - Wide hydraulic range
 - Multiple configurations
 - Parts interchangeability
 - Materials options
- **Low total life cycle costs**
 - Low operating costs
 - Low energy costs
 - Reduced inventory requirements
 - Low maintenance costs
 - Increased uptime

**MEN Series
Single-Stage,
End Suction
Water Pumps**

MEN
MENBLOC
ME

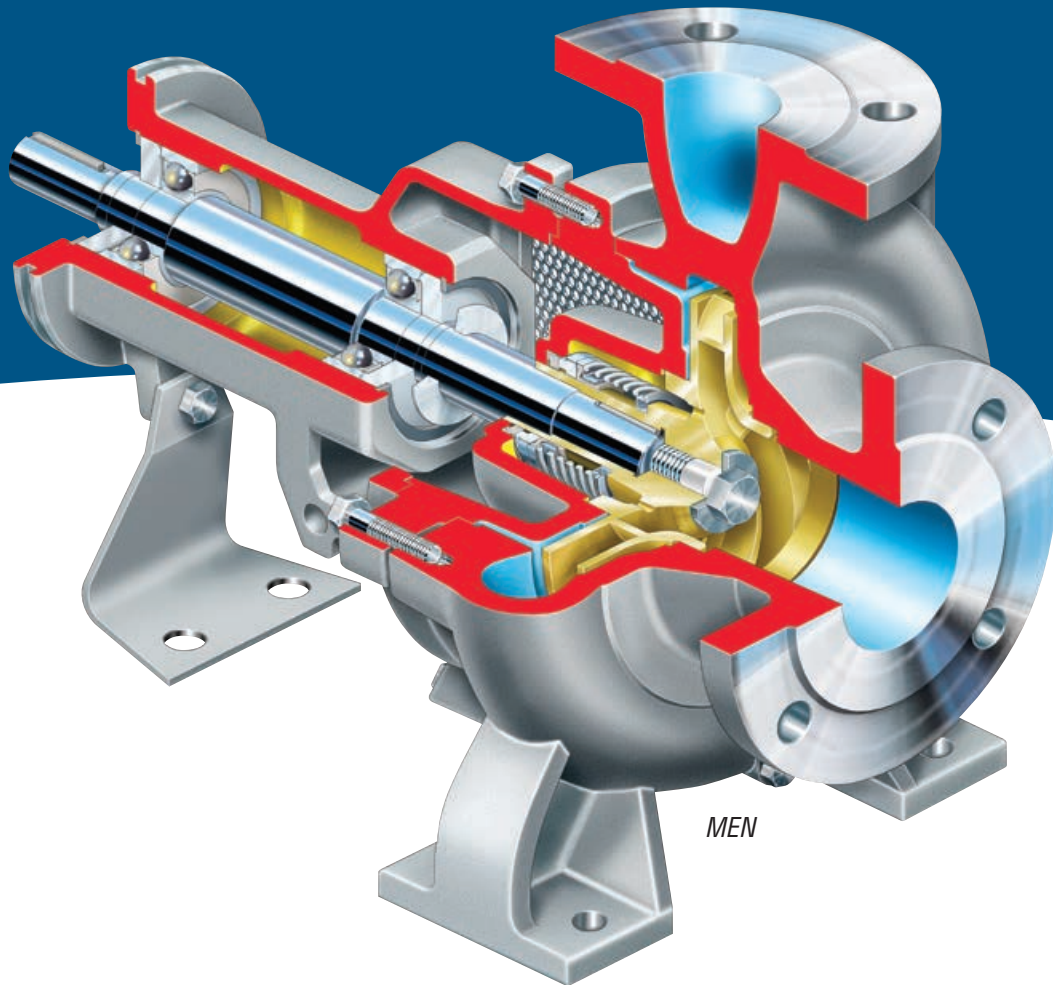

MEN—The Workhorse

MEN pumps are the preferred choice for many water, light chemical and general industry applications. Ruggedly built, they provide years of reliable performance with minimal maintenance.

Available in 35 sizes, the MEN is available in standard, high-capacity and high-pressure models.

- 15 sizes comply with both the dimensional and hydraulic requirements of EN 733 and DIN 24 255 (latest editions).
- 18 sizes comply only with the dimensional requirements of EN 733 (latest edition). The high-capacity hydraulics exceed the specification's performance requirements.
- 2 sizes are designed for high-pressure applications. These sizes do not comply with EN 733 and DIN 24 255.

Operating Parameters

- Flows to 800 m³/h (3520 gpm)
- Heads to 140 m (450 ft)
- Discharge pressures to 16 bar (230 psi)
- Temperatures from -10°C to 120°C (15°F to 250°F)

Features and Benefits

Single Volute Casing Design has a centerline discharge and raised face flanges to ISO PN 10/16 or ANSI B16.1 specifications. Back pull-out design facilitates inspection and maintenance.

Precision Cast Closed Impeller has machined shrouds and is dynamically balanced for high efficiency. Axial thrust is minimized by a balancing chamber and holes on the rear side.

Integral, One-piece Cast Iron Bearing Frame provides excellent rigidity and concentricity to minimize vibration. Three bearing frame sizes apply: 24, 32 and 42. All sizes utilize large diameter greased-for-life bearings.

Open Seal Chamber features integral vortex breaking ribs to extend the life of mechanical seals.

Standard Internal Elastomeric Bellows Mechanical Seal is bidirectional in operation and readily accommodates misalignment, end-float and seal face wear.

Oversized Stainless Steel Shaft is conservatively designed to minimize deflection and reduce wear.

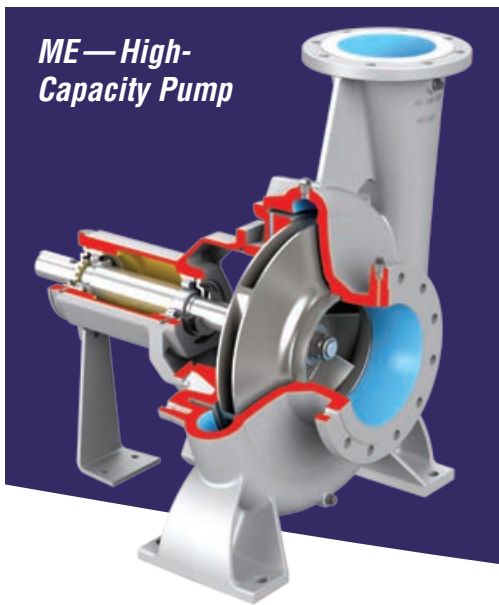

ME—High-Capacity Pump

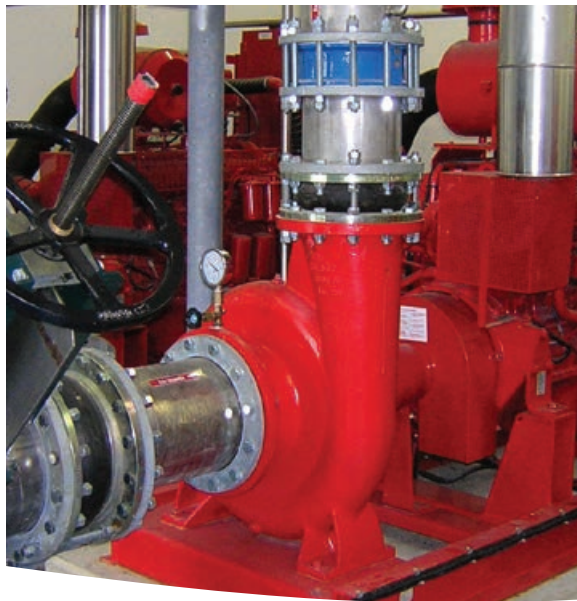

ME—High-Capacity Model

Of all the models in the MEN Series, the ME boasts the highest flow rates. The pump's key differentiating feature is its tangential discharge, which is optimized for high-capacity performance.

Available in 21 sizes.

Operating Parameters

- Flows to 3000 m³/h (13 208 gpm)
- Heads to 110 m (361 ft)
- Discharge pressures to 16 bar (230 psi)
- Temperatures to 120°C (250°F)



MENBLOC—Close Coupled Configuration

MENBLOC is the close coupled configuration of the MEN pump. Not requiring a baseplate or coupling, it is an economical alternative to the frame mounted MEN. Its reduced footprint also permits its use in tight areas.

Wet-end components comply with the latest editions of EN 733 and DIN 24 255.

Available in 69 sizes. Uses 50 Hz drivers only.

Operating Parameters

- Flows to 340 m³/h (1500 gpm)
- Heads to 100 m (330 ft)
- Discharge pressures to 16 bar (230 psi)
- Temperatures to 120°C (250°F)



Options and Technical Data

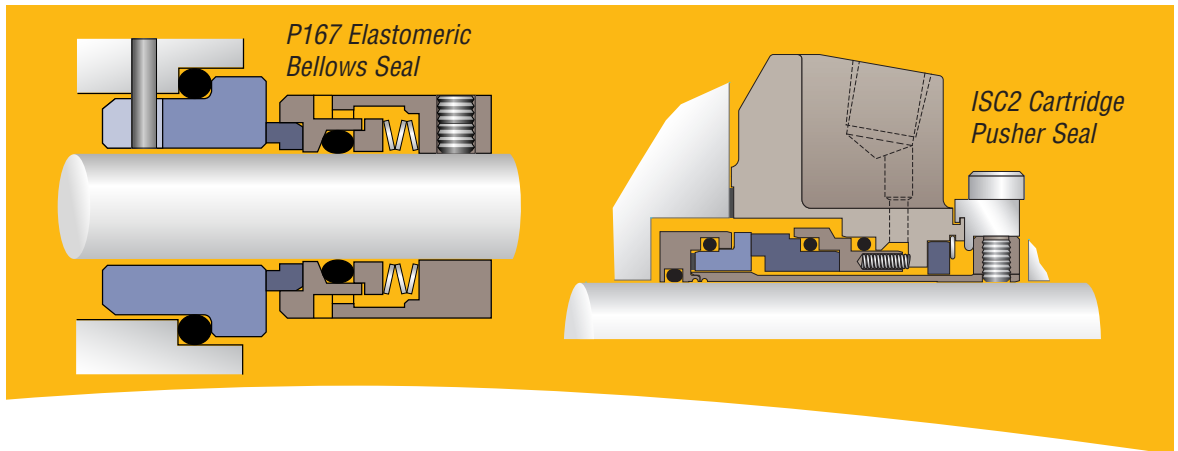

Shaft Sealing Options

- Internal elastomeric bellows mechanical seal
 - Pac-Seal P220 is standard on size 24, 32 and 42 bearing frames
 - Pac-Seal P167 is standard on size 55 and 70 bearing frames
- Optional ISC2 single cartridge pusher seal may be specified on the stainless steel MEN for more demanding applications.
- Packing

Additional Options

- ISO or ASME (ANSI) flanges
- Casing wear rings
- Vertical lineshaft and cantilevered configurations
- ATEX and/or GOST certification

Materials of Construction*

Component	Cast Iron		Stainless Steel	
	Standard	Option	Standard	Option
Casing	Cast Iron	-	Stainless Steel	-
Cover	Cast Iron	-	Stainless Steel	-
Impeller	Cast Iron	Bronze	Stainless Steel	-
Wear Rings	-	13% Cr Steel	-	13% Cr Steel
Bearing Housing	Cast Iron	-	Cast Iron	-
Shaft	13% Cr Steel	-	13% Cr Steel	-

* Consult the factory or a Flowserve representative for alternative materials of construction.

MEN Range Chart

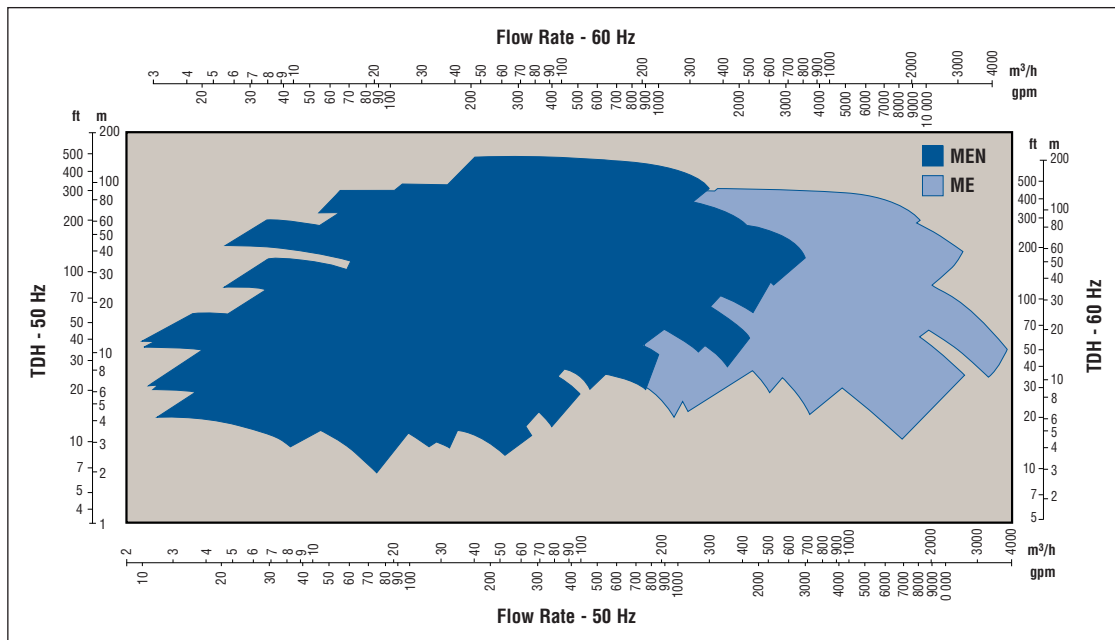

Global Service
and Technical
Support

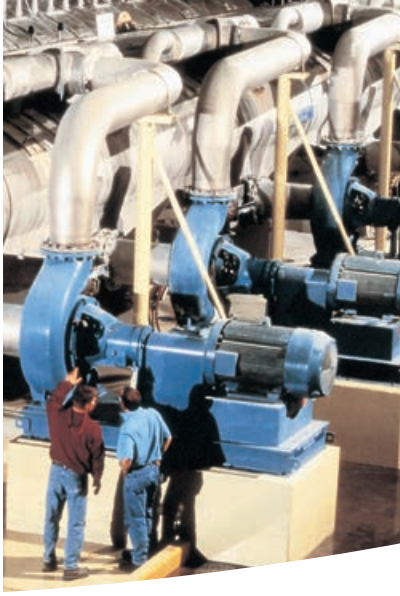

Life Cycle Cost Solutions

Typically, 90% of the total life cycle cost (LCC) of a pumping system is accumulated after the equipment is purchased and installed. Flowserve has developed a comprehensive suite of solutions aimed at providing customers with unprecedented value and cost savings throughout the life span of the pumping system. These solutions account for every facet of life cycle cost, including:

Capital Expenses

- Initial purchase
- Installation

Operating Expenses

- Energy consumption
- Maintenance
- Production losses
- Environmental
- Inventory
- Operating
- Removal

Innovative Life Cycle Cost Solutions

- New Pump Selection
- Turnkey Engineering and Field Service
- Energy Management
- Pump Availability
- Proactive Maintenance
- Inventory Management

Typical Pump Life Cycle Costs¹

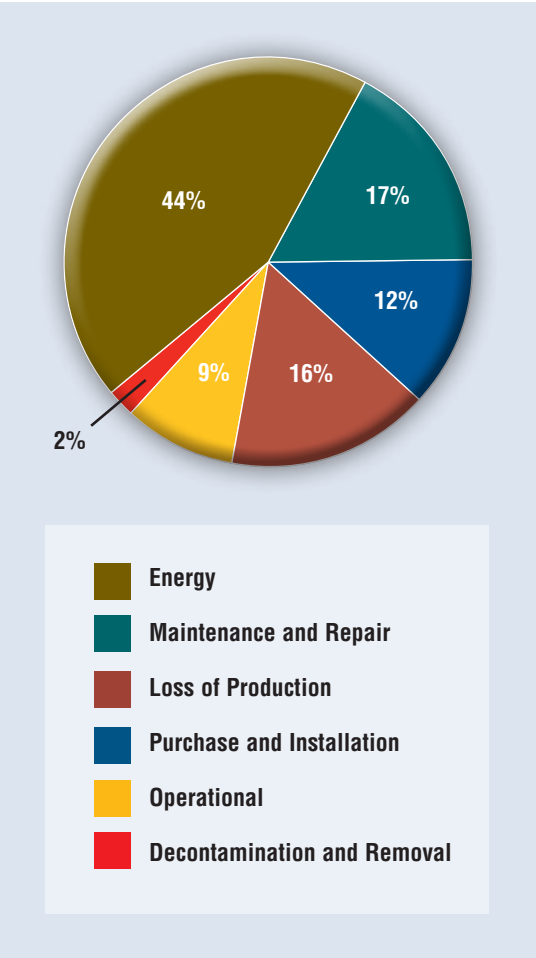

¹ While exact values may differ, these percentages are consistent with those published by leading pump manufacturers and end users, as well as industry associations and government agencies worldwide.

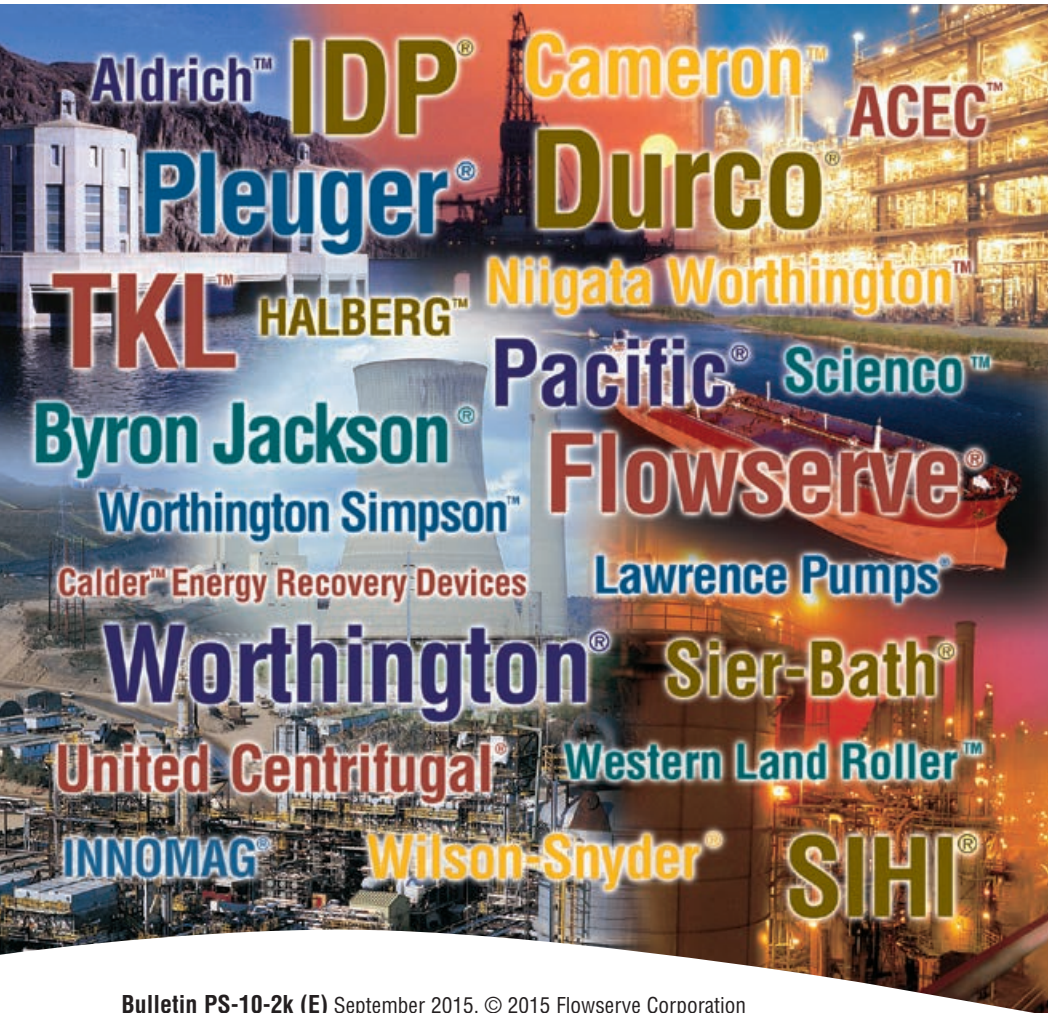

USA and Canada

Flowserve Corporation
5215 North O'Connor Blvd.
Suite 2300
Irving, Texas 75039-5421 USA
Telephone: +1 937 890 5839

Europe, Middle East, Africa

Flowserve Corporation
Parallelweg 13
4878 AH Etten-Leur
The Netherlands
Telephone: +31 76 502 8100

Latin America

Flowserve Corporation
Martín Rodríguez 4460
B1644CGN-Victoria-San Fernando
Buenos Aires, Argentina
Telephone: +54 11 4006 8700
Telefax: +54 11 4714 1610

Asia Pacific

Flowserve Pte. Ltd.
10 Tuas Loop
Singapore 637345
Telephone: +65 6771 0600
Telefax: +65 6862 2329

Bulletin PS-10-2k (E) September 2015. © 2015 Flowserve Corporation

To find your local Flowserve representative:

For more information about Flowserve Corporation,
visit www.flowserve.com or call +1 937 890 5839.