

The simplest ideas are often the best

‘500 Range’

Cost-effective pumps for ultimate product compatibility



'500 Style' plastic pumps



Flotronic Pumps Ltd have long realised that metal pumps aren't always the right choice.

That's why we developed the '500 Style' pump. Engineered from a choice of plastics, the '500 Style' is a cost-effective means of meeting the challenges presented by transfer applications that demand a product-compatible pump. Solvents, dyes and other specialist chemicals present no problems with the '500 Style' - which is also ideal for handling various acids and other chemicals where plastics offer maximum product compatibility.

The '500 Style' design comprises a solid plastic body and manifolds. These are supported by metal air domes, top and bottom plates and through studs, offering safety without compromising fast maintenance. In common with other Flotronic pumps, the '500 Style' can be modified for ATEX compliance.

The '500 Style' also utilises Flotronic's innovative, easy 'One-Nut' design with lubrication free air valve, allowing easy pump maintenance in a matter of minutes.

Performance to match any requirements.

- **self-priming, suction lift (3.6m/12ft dry and 8m/26ft wet)**
- **temperature range up to 80°C (176°F)**
- **flow rates up to 908 ltr/min**
- **screwed or flanged connections are available as standard including BSPT/BSPP/NPT/RJT/IDF/ISS/DIN/ANSI/BS (with other specialist connections available on request)**

Flotronic's commitment to high quality management of the processes that create and control our products has been recognised in the achievement of the ISO 9001 accreditation, the internationally recognised standard for quality management of businesses.

Flotronic '500 Style'

The impressive features and benefits of the 500 range:

- a range of ½” to 3” connections
- can run dry
- can stop/restart against closed/open valve without pressure relief or damage
- ATEX Directive compliant
- only one nut to access diaphragms with pump 'in-line'
- easy maintenance access to balls and seats
- bolt on external air valve allowing ease of maintenance with pump in-line
- no lubrication required
- with environmental protection in mind, Diaphragm Rupture Protection and fully pneumatic Alarm Systems are available
- latest designs eliminate the costly internal air mechanisms normally associated with Double Diaphragm pumps
- two or four wheel trolleys are available for easy pump transportation.

All of which help you to:

- transfer an extensive variety of materials efficiently across a range of industries
- reduce down time maintenance and production costs
- benefit from a versatile and cost effective pumping solution

Applications:

- bulk chemical transfer
- CIP chemical systems
- bund wall applications
- coatings
- paints
- adhesives

Optional construction materials:

Wetted Parts

Body and Manifolds: Polypropylene, PVC, Polyethylene and Aluminium

Thrust Tube: 316 Stainless Steel, or Polypropylene, PVC, PVDF sleeved

Diaphragms: PTFE faced with Nitrile and EPDM backing, solid Nitrile, solid EPDM as required

Divider Seals: PTFE, Nitrile

Manifold Seal Rings: PTFE, Nitrile, EPDM

Balls: PTFE, Nitrile, 316 Stainless Steel, EPDM

Seats: Polypropylene, PVC, Polyethylene

Non-wetted parts

E version: Coated Carbon Steel

S version: Stainless Steel



Technical Data

Flow Rate 7" diameter diaphragm 1/2"

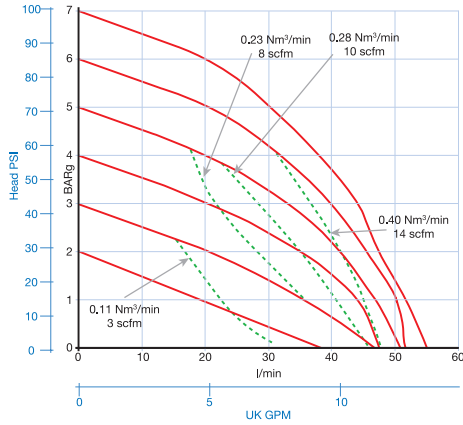

Flow Rate 12" diameter diaphragm 3"

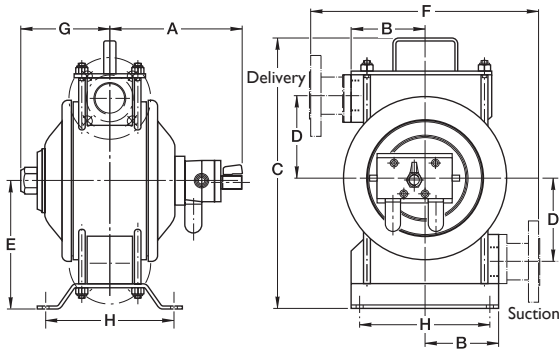
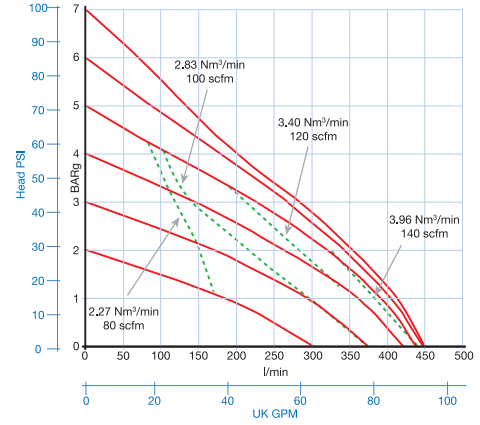

Polypropylene, PVC, PVDF & Aluminium										Diaphragm Diameter
Size	A	B	C	D	E	F	G	H	Wt/kg	
1/2" - 1"*	223	87	323	110	178	225	116	130	13†	7"
1/2"	190	114	360	115	170	355	140	203	19†	10"
1"	230	114	390	121	186	355	140	203	21†	10"
1 1/2"	230	114	419	129	200	355	140	203	21†	10"
2"	230	163	450	132	215	450	140	203	22†	10"
1 1/2" - 2" - 3"*	345	150	522	189	289	323	210	220	50†	12"
2" - 3"	350	190	545	148	270	550	235	330	75†	14"

Maximum operating pressure 7.2 bar (105 PSIG)

* Vertical delivery on these pumps

† For Aluminium weight please contact Flotronic

Dimensions in mm

Unibloc Hygienic Technologies, LLC
 Ricebridge Works, Brighton Road, Bolney, West Sussex RH17 5NA. UK
 Tel: +44 (0)1444 881871 Fax: +44 (0)1444 881860
 E-mail: sales@unibloctech.com Web: unibloctech.com
 For authentic Flotronic pump spares go to: unibloctech.com



Hastelloy® is a registered trademark of Haynes International.

'Flotronic' is a UK registered trade mark.

Specifications subject to change without notice.



Flotronic 'One - Nut' pumps - The simplest ideas are often the best