

Multistage Centrifugal Pumps

HEGA 2502 ... 8009

TECHNICAL DATA

Flow:	max. 190 m ³ /h
Head:	max. 425 m
Speed:	max. 3600 rpm
Material:	Cast iron (0B, 0C, 0D, 0E, 0R, 0S, 0U) Stainless steel (4B)
Temperature:	max. 190 °C, depending on the shaft sealing and the materials execution.
Casing pressure:	max. 40 bar, depending on the operating temperature.
Shaft seal:	Stuffing box or mechanical seal.
Flange connections:	Suction flange, according to DIN 2501 PN 16, Discharge flange, according to DIN 2501 PN 40
Direction of rotation:	To the right (clockwise), when looking at the pump from the drive end.

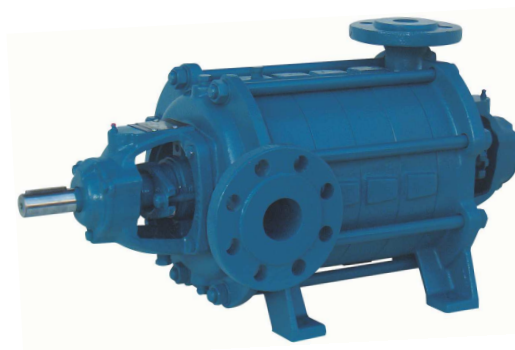

APPLICATION

Series HEG multistage centrifugal pumps are used in applications where the requirement is for trouble-free pumping of clear or slightly dirty liquids. They are used in:

- Heating plants
- Waterworks and water supply plants
- Pressure raising plants
- Circulating water and condensate plants
- Fire extinguishing plants
- Purification plants
- Irrigation plants
- Boiler feed water plants
- Pressurized water producing stations

DESIGN

Horizontal multistage centrifugal pumps with sectional casing and closed impellers.

The manufacturing program covers six sizes, with 2 up to maximum 13 stages, according to the size, the speed and the shaft seal. Axial thrust balancing is carried out by balancing the impellers separately. The remaining axial thrusts are taken up by adequately sized antifriction bearings.

The impellers, diffusers, as well as the wear ring from size 65, are interchangeable between stages.

Arrangements combining impellers of different diameters permit, within the application field, optimum matching to the required performance characteristics with the performance curve.

On the suction side, the mounting feet are arranged on the casing of the first stage. By this means, it is possible to ensure easy adaptation to different installation conditions, even subsequent to initial installation, by pivoting the suction head casing.

The driver is arranged on the suction side but discharge side driver or driver on both sides are possible on request.

All sizes can be supplied with one or more dummy stages, on request.

CONSTRUCTION

Casing pressure [bar]:

Discharge casing	Suction casing	Temperature range ⁽¹⁾
max. 40	max. 16	-10 to 120 °C
max. 38	max. 16	up to 140 °C
max. 32,6	max. 13	up to 194 °C

(1) Take in mind the application limit for the shaft seal

Discharge casing pressure = suction pressure + zero flow head.

Please note: The relevant technical regulations and safety rules must be observed.

Flanges:

Suction side flange according to DIN 2533 PN16, discharge side flange according to DIN 2535 PN40.

The flanges can be drilled according to ANSI B16.1 class 250, on request.

Flange positions:

Suction flange arranged horizontally towards the right hand side (looking on the shaft end) and discharge flange radially upwards.

On request, the suction flange can be arranged on the left and, in the case of pumps with three or more stages, also vertically upwards.

Bearings:

One cylindrical roller bearing according to DIN 5412 on the shaft end side and one deep-groove ball bearing according to DIN 625 on the discharge side, both lubricated by grease.

On request, a four point contact ball bearing or two single row angular contact ball bearings mounted in X arrangement, can be supplied on the discharge side.

Shaft sealing:

Sealing of the shaft can be carried out either by a stuffing box or mechanical seal as required.

- Designation 001:
Uncooled stuffing box.
Temperature range: -10 up to 110 °C.
- Designation 022:
Externally flushed, uncooled, lengthened stuffing box (nonavailable for sizes 25 and 32).
Temperature range: -10 o 110 °C.
- Designation 511:
Cooled stuffing box.
Temperature range: up to 140 °C (up to 194 °C to consult).
- Designation BK3/BKS/BKU:
Unbalanced single mechanical seal with rubber bellows and self-circulation.
Temperature range: -10 °C up to 110 °C
- Designation BX3/BXS/BXU:
Equivalent to BK3/BKS/BKU plus refrigeration/heating chamber.
Temperature range: up to 140 °C

Materials of construction:

Item	Component	Material					Construction ⁽¹⁾							
		Mat. Nr.	DIN denomination	ISO-EN denomination	US Material		0B	0C	0D	0E	0R	0S	0U	4B
					ASTM standard	AISI								
10.6	Suction casing	0.6025	GG-25	EN-GJL 250	A278 Cl. 30		x	x	x	x	x	x	x	
		1.4408	GX6CrNiMo18-10	GX5CrNiMo19-11-2	A351 CF8M	316								x
10.7	Discharge casing	0.6025	GG-25	EN-GJL 250	A278 Cl. 30		x	x	x	x	x	x	x	
		1.4408	GX6CrNiMo18-10	GX5CrNiMo19-11-2	A351 CF8M	316								x
10.8	Stage casing	0.6025	GG-25	EN-GJL 250	A278 Cl. 30		x	x	x	x	x	x	x	
		1.4408	GX6CrNiMo18-10	GX5CrNiMo19-11-2	A351 CF8M	316								x
23.0	Impeller	0.6025	GG-25	EN-GJL 250	A278 Cl. 30		x				x			
		2.1060	G-CuSn12 Ni	EN-CC484K	B427 C91700			x	x			x		
		1.4408	GX6CrNiMo18-10	GX5CrNiMo19-11-2	A351 CF8M	316				x			x	x
17.1	Diffuser	0.6025	GG-25	EN-GJL 250	A278 Cl. 30		x	x		x	x	x	x	
		2.1060	G-CuSn12 Ni	EN-CC484K	B427 C91700				x					
		1.4408	GX6CrNiMo18-10	GX5CrNiMo19-11-2	A351 CF8M	316								x
21.1	Shaft	1.7225	42 CrMo 4	42CrMo4	A322 Gr. 4140	4140	x	x	x	x				
		1.4021	X20CrMo 13	X20CrMo13	A276 Gr. 420	420					x	x	x	x
52.4	Shaft sleeve (stuffing box)	1.4021	X20CrMo 13	X20CrMo13	A276 Gr. 420	420	x	x	x	x	x	x	x	x
52.32	Shaft sleeve (mec. seal)	1.4301	X5CrNi 18-9	X5CrNi18-9	A276 Gr. 304	304	x	x	x	x	x	x	x	x
46.1	Stuffing box	Synthetic fiber with PTFE impregnation					x	x	x	x	x	x	x	x
43.3	Mechanical seal	AQ1EGG [Carbon graphite / Silicon carbide / EPDM ⁽²⁾] AQ1VGG [Carbon graphite / Silicon carbide / FKM ⁽²⁾ (Viton)] Q1Q1VGG [Silicon carbide / Silicon carbide / FKM ⁽²⁾ (Viton)]					x	x	x	x	x	x	x	x

(1) Other combinations are possible. Please consult with the factory.

(2) Short way according to ISO 1629.

Casing gasket:

The casings are sealed by means of Perbunan o'rings. Code of this execution: P.

For temperature over 140 °C up to 194 °C, the casings are sealed with Viton o'rings. Code of this execution: V.

Motor power, speed and number of stages:

By means of standard electrical motors, type of construction IM B3.

The following maximum numbers of stages as a function of shaft seal and speeds, must be observed :

Pump size	Maximum speed [rpm]	Maximum number of stages according to the shaft seal				
		001	022	511	BK3/BKS/BKU	BX3/BXS/BXU
2500	1 800	13	-	11	13	11
	3 000	11	-	11	13	11
	3 600	8	-	8	10	8
3200	1 800	12	-	10	12	10
	3 000	9	-	9	11	9
	3 600	6	-	6	7	6
4000	1 800	12	10	10	12	10
	3 000	8	8	8	9	8
	3 600	6	6	6	6	6
5000	1 800	11	9	9	11	9
	3 000	6	6	6	8	6
	3 600	4	4	4	5	4
6500	1 800	10	8	8	10	8
	3 000	5	5	5	6	5
	3 600	3	3	3	4	3
8000	1 800	9	7	7	9	7
	3 000	4	4	4	5	4
	3 600	2	2	2	3	2

General notes:

The following additional design is available: **HESB**: Vertical multistage centrifugal pumps, base supported for casing pressures up to 25 bar.

Sectional drawing and list of parts

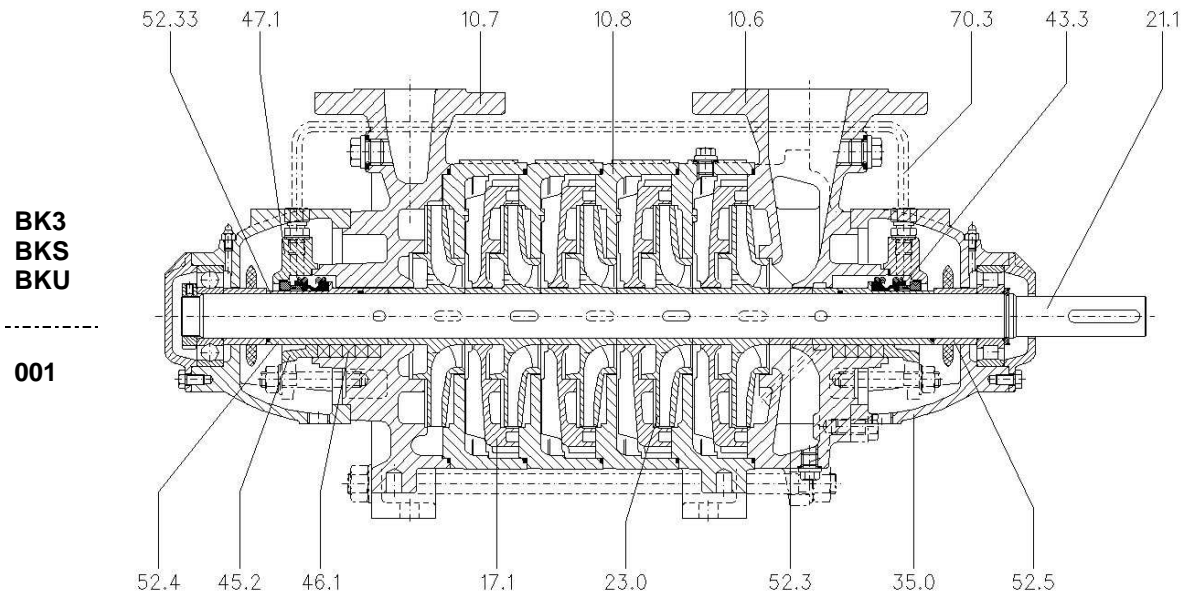

BK3
BKS
BKU

001

10.6	Suction casing	43.3	Mechanical seal	50.21	Wear ring ⁽¹⁾
10.7	Discharge casing	45.1	Stuffing box housing	52.3	Spacer sleeve
10.8	Stage casing	45.2	Stuffing box gland	52.31	Spacer sleeve
17.1	Diffuser	45.8	Lantern ring	52.33	Shaft protection sleeve
21.1	Shaft	46.1	Stuffing box	52.4	Shaft protection sleeve
23.0	Impeller	47.1	Seal cover	52.5	Spacer sleeve
35.0	Bearing housing	50.2	Wear ring ⁽¹⁾	70.3	Liquid circulating tube

(1) Wear rings are used only in sizes 65 and 80

Other types of shaft sealing arrangement:

Execution 022 ⁽²⁾

Uncooled, lengthened stuffing box with external flushed.

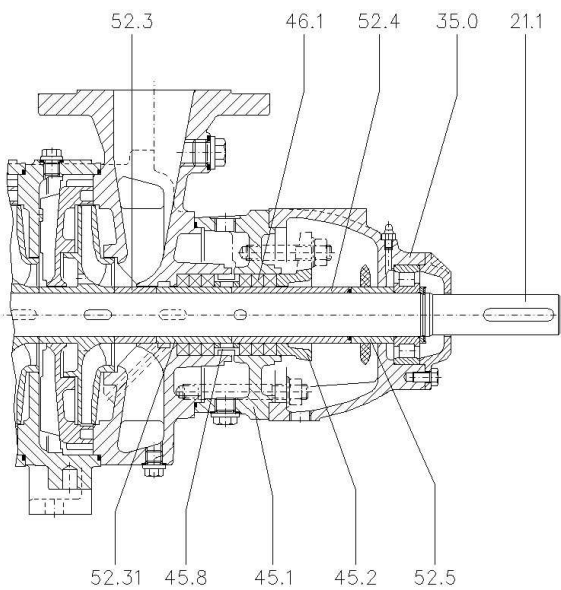

Execution 511 – Execution BX3/BXS/BXU

Cooled stuffing box – Refrigeration / Heating chamber.

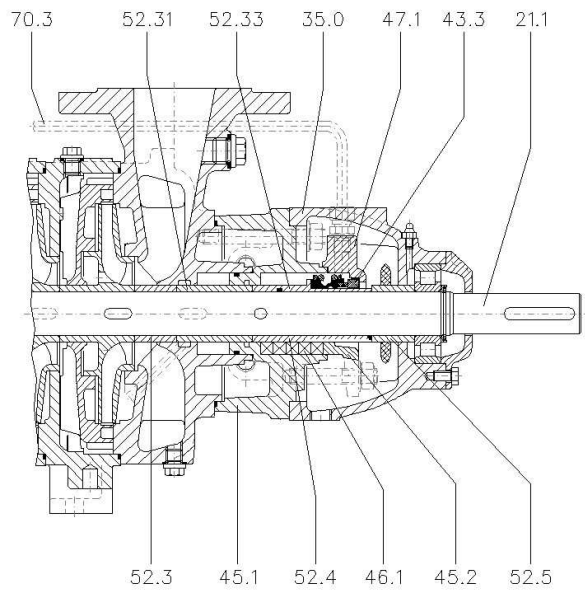

BX3
BXS
BXU

511

(2) Non-available for sizes 25 and 32

Field chart 50 Hz

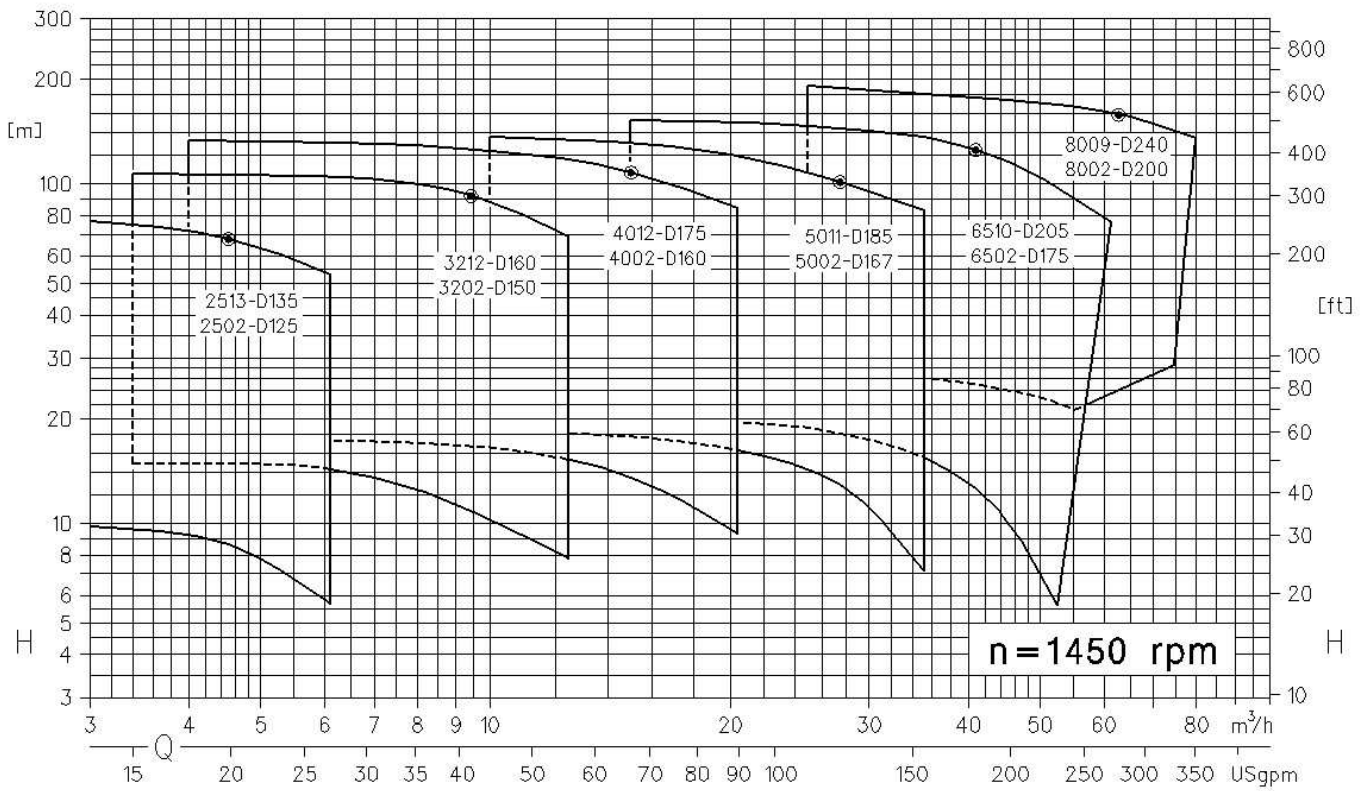
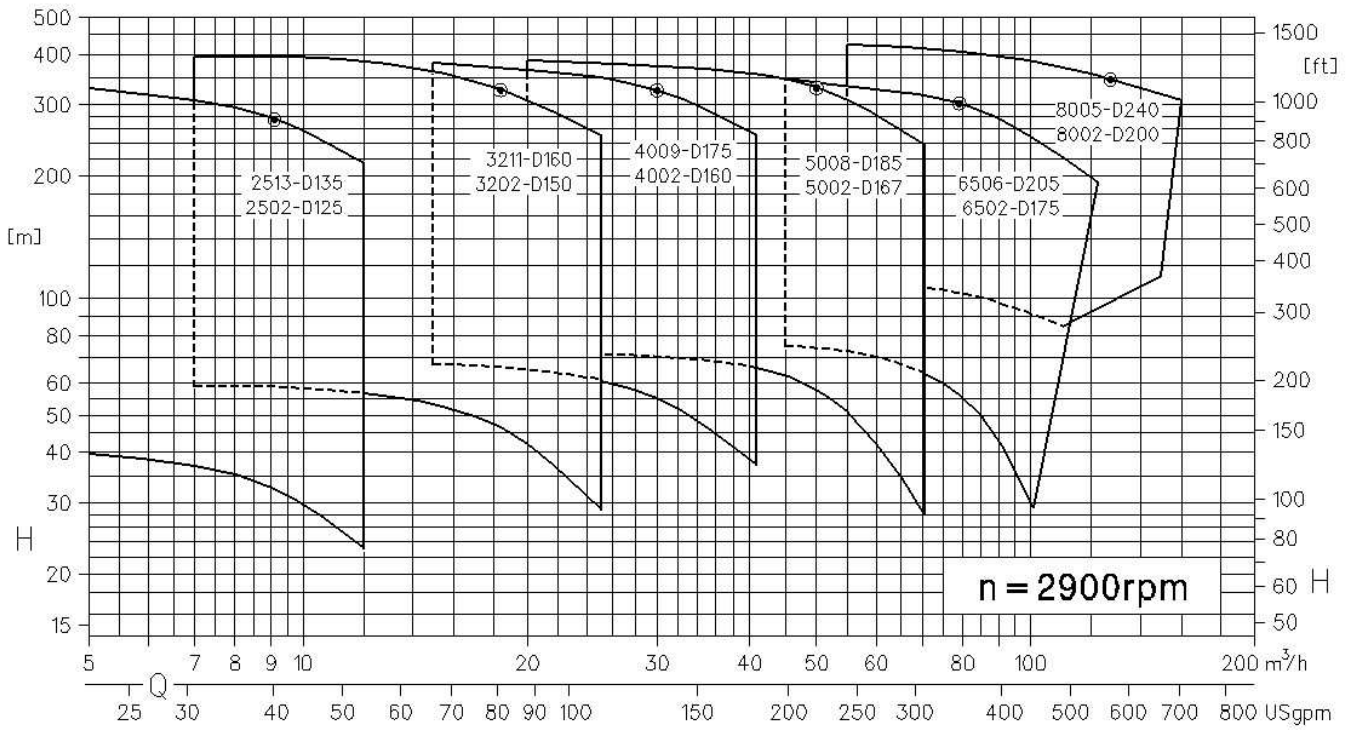

Field chart 60 Hz

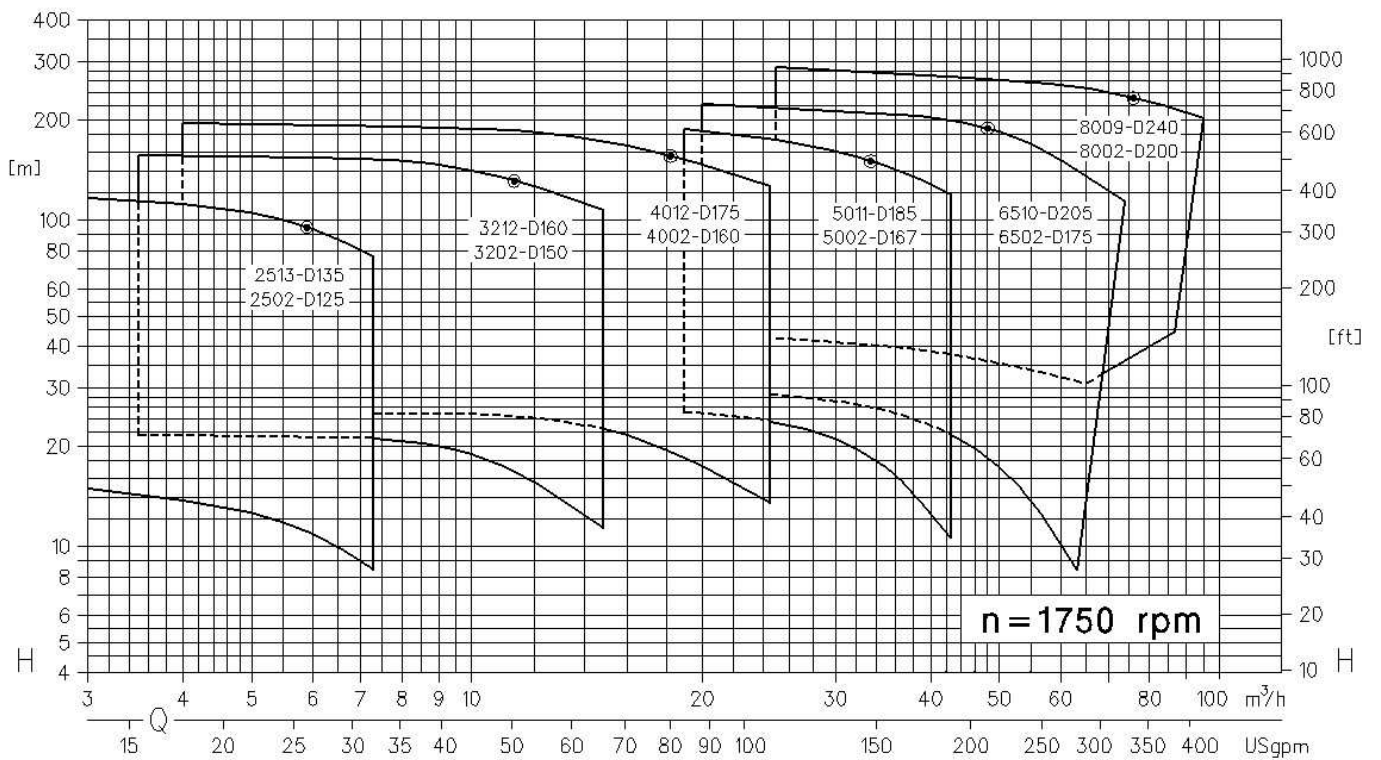
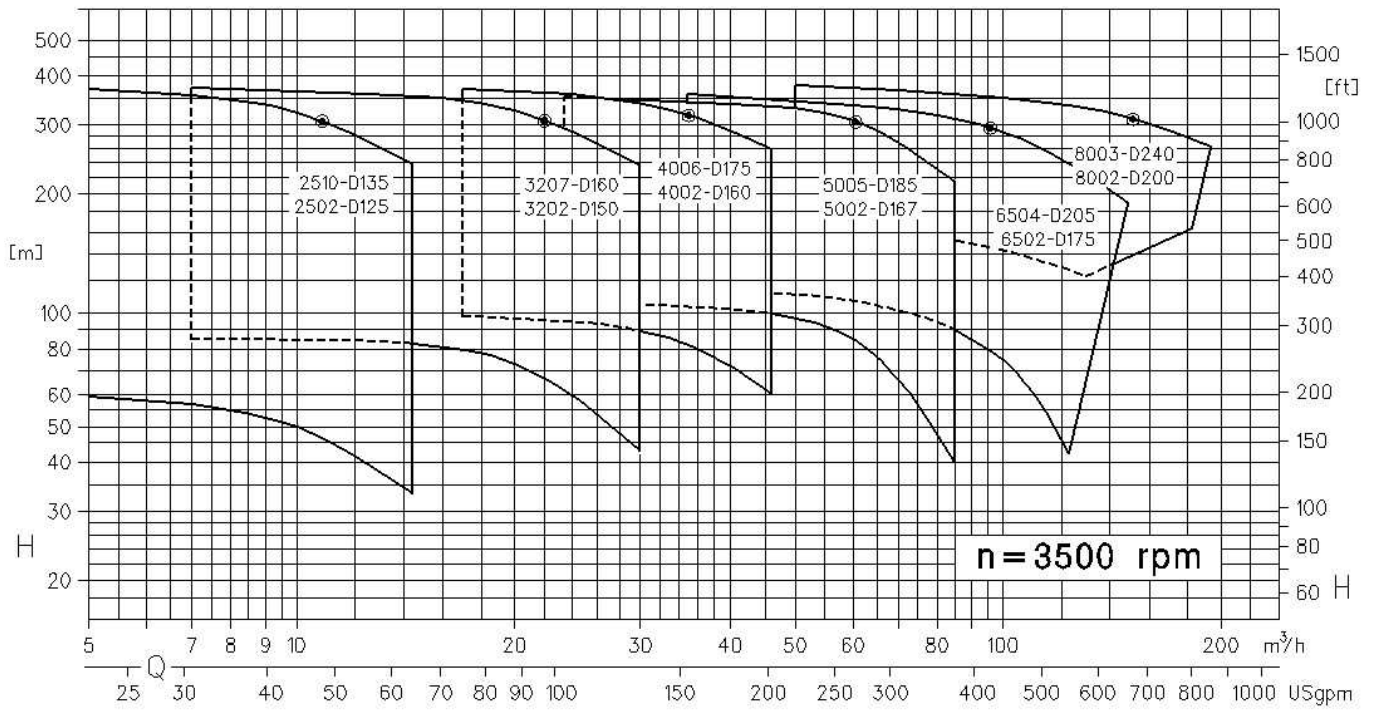

Performance curves

HEGA 25

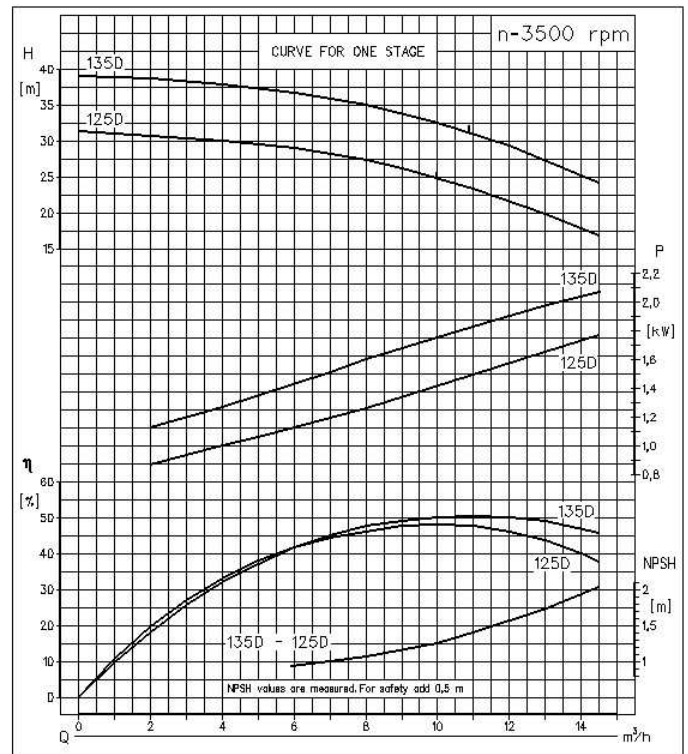
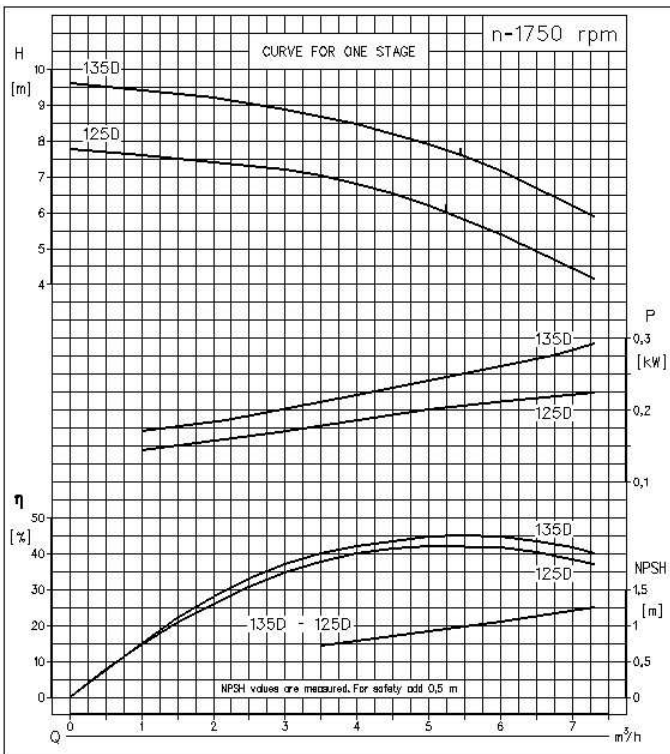
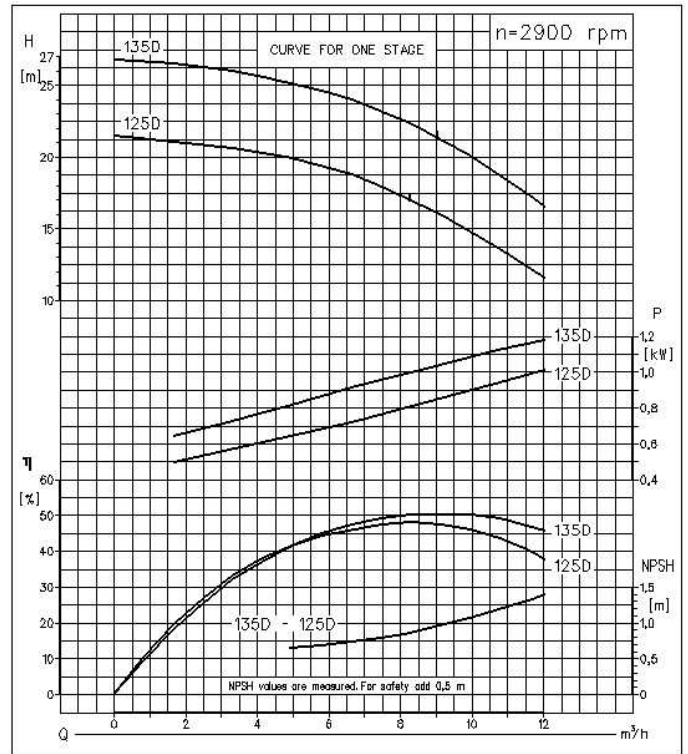
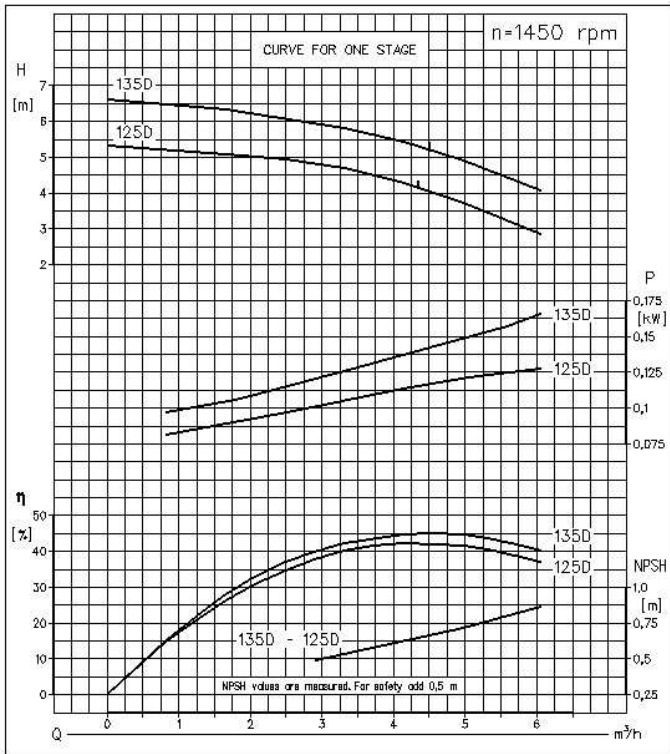

- Not valid for materials of construction 4B (stainless steel). Please consult with the factory.
- Head or Power for more than one stage = Head or Power for one stage multiplied by number of the stages.

Performance curves

HEGA 32

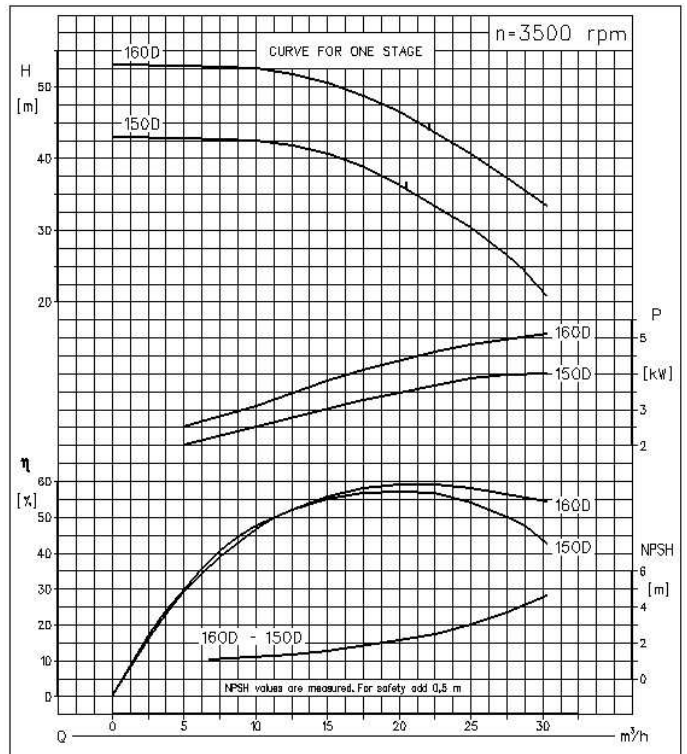
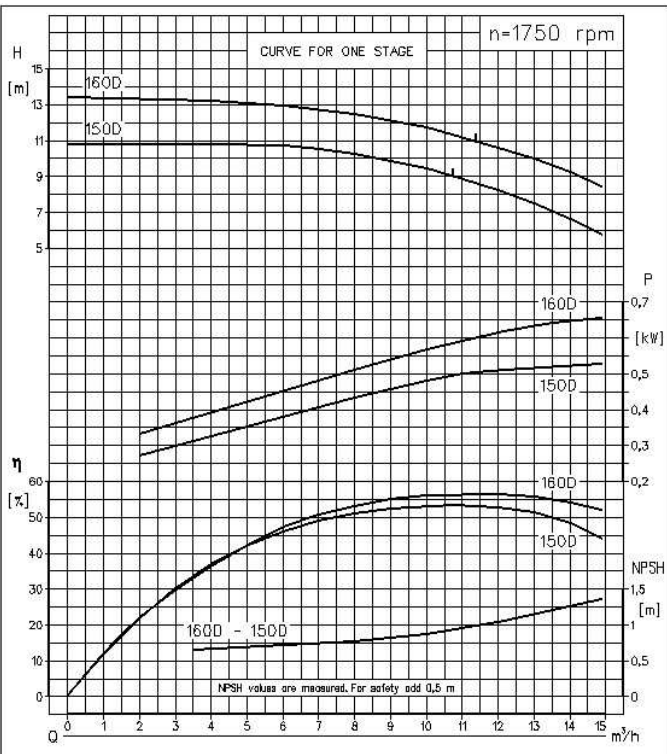
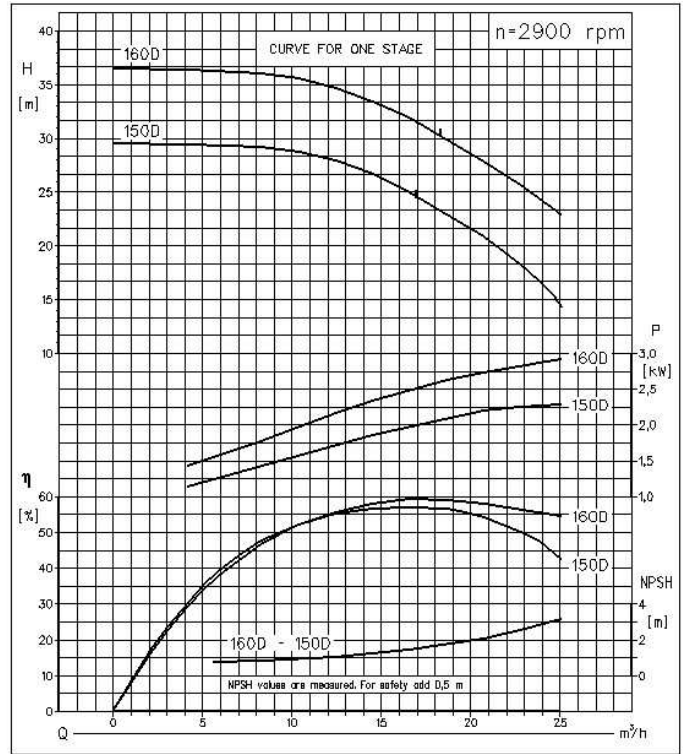
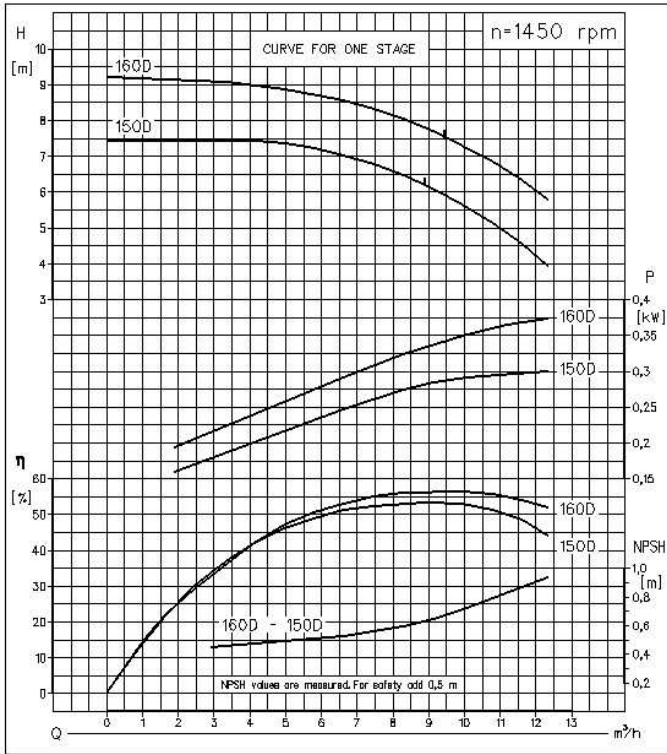

- Not valid for materials of construction 4B (stainless steel). Please consult with the factory.
- Head or Power for more than one stage = Head or Power for one stage multiplied by number of the stages.

Performance curves

HEGA 40

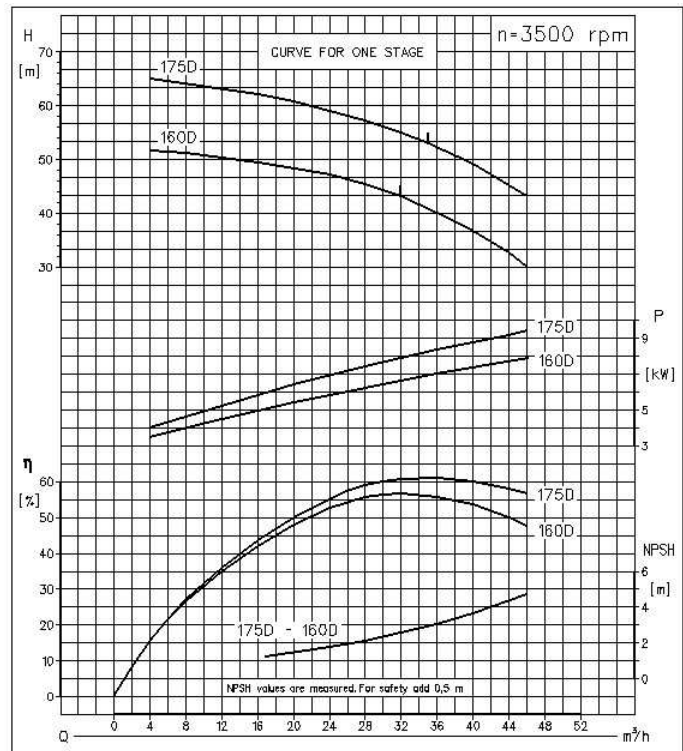
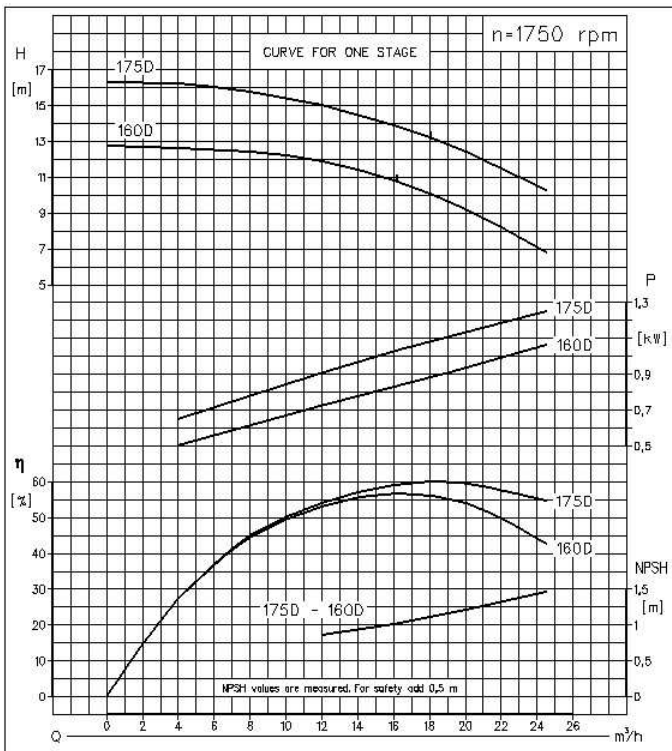
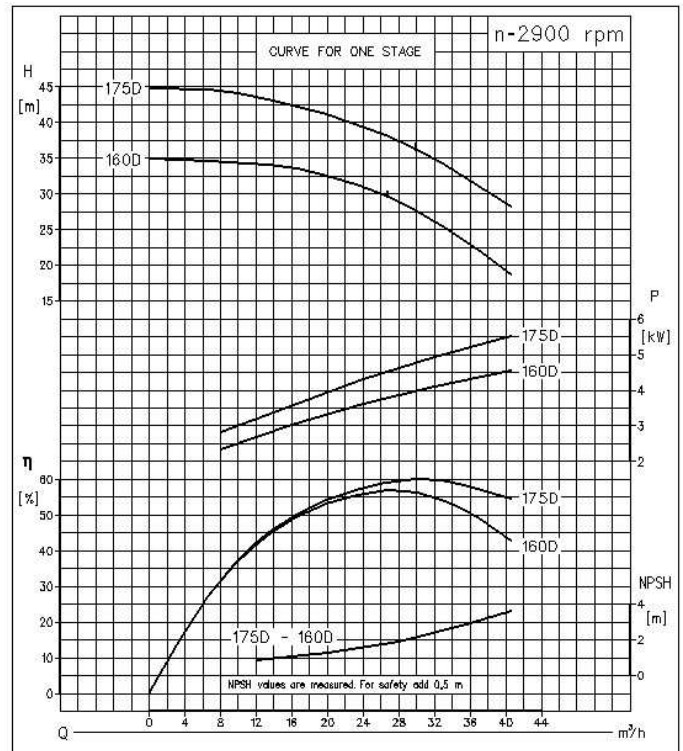
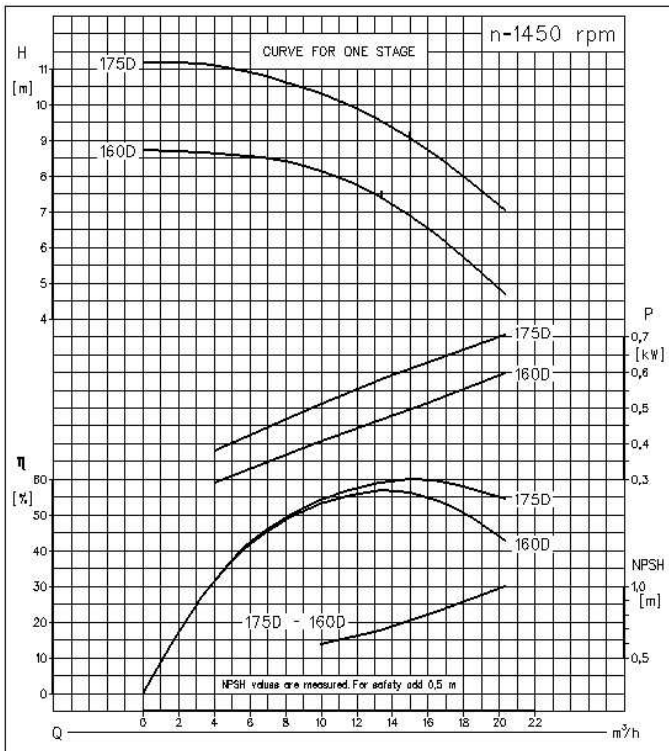

- Not valid for materials of construction 4B (stainless steel). Please consult with the factory.
- Head or Power for more than one stage = Head or Power for one stage multiplied by number of the stages.

Performance curves

HEGA 50

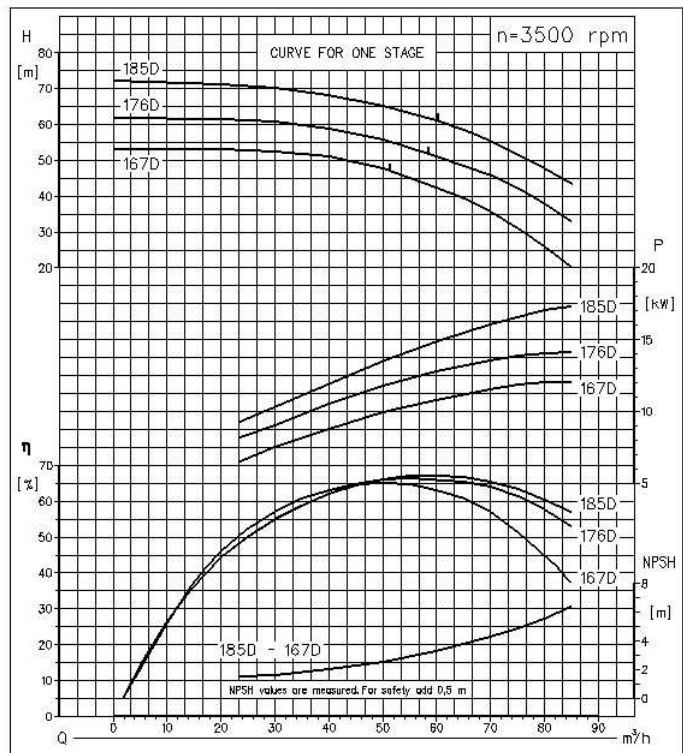
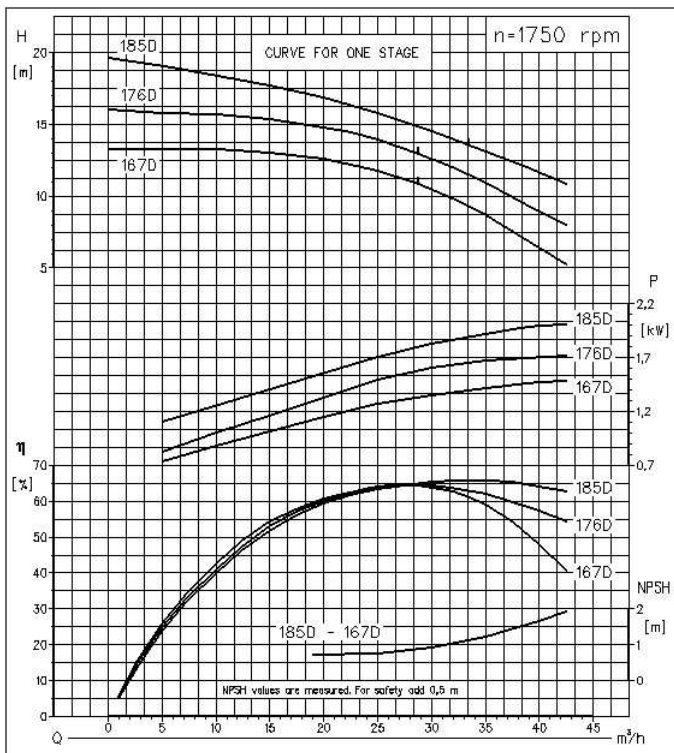
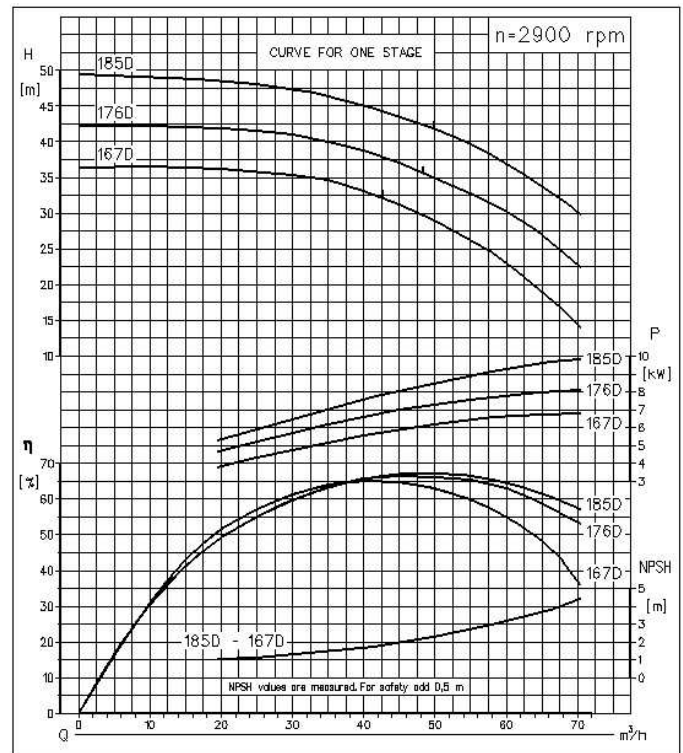
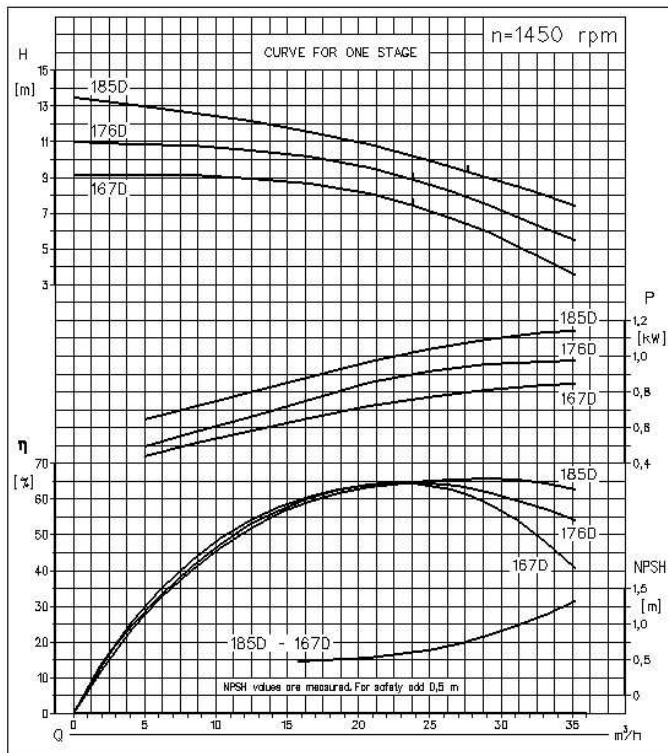

- Not valid for materials of construction 4B (stainless steel). Please consult with the factory.
- Head or Power for more than one stage = Head or Power for one stage multiplied by number of the stages.

Performance curves

HEGA 65

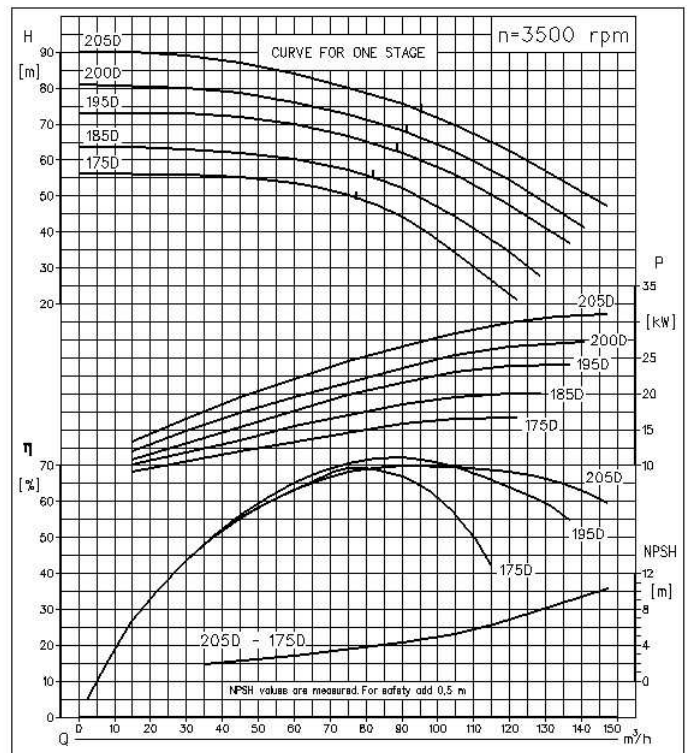
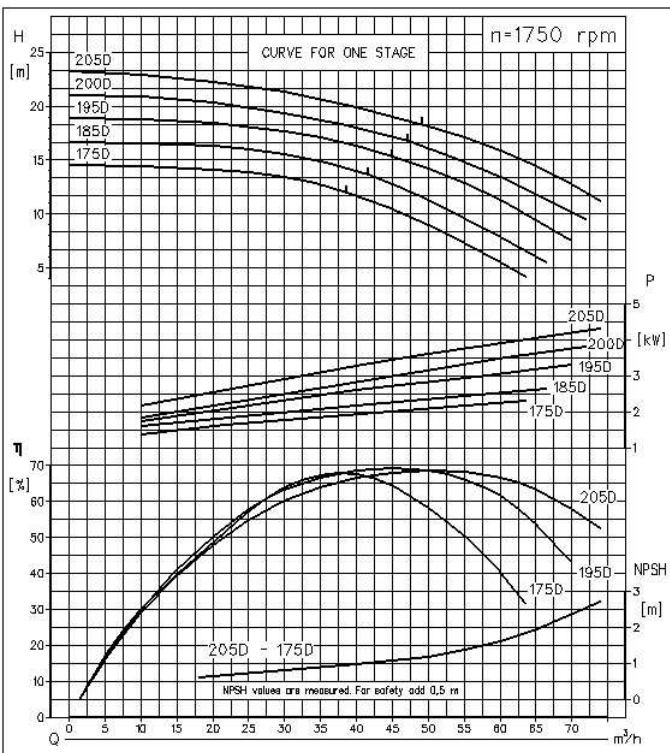
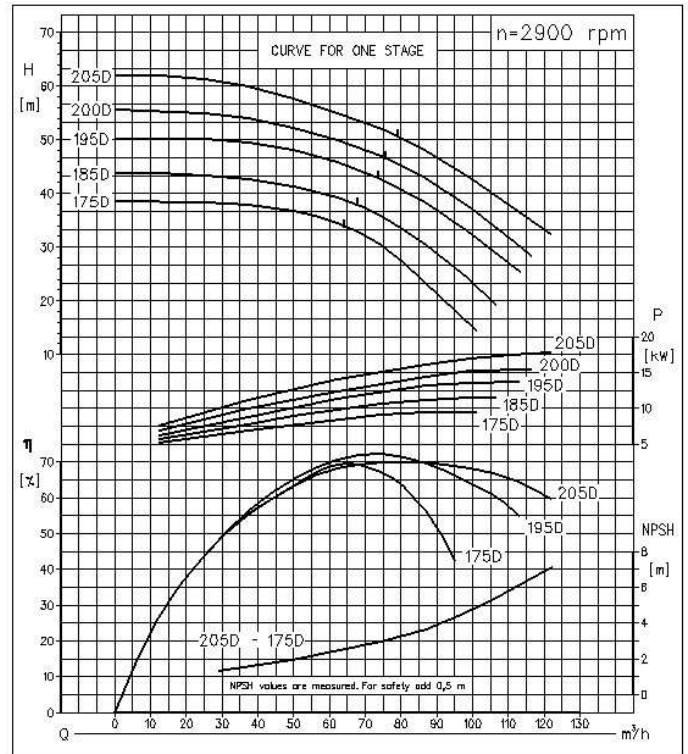
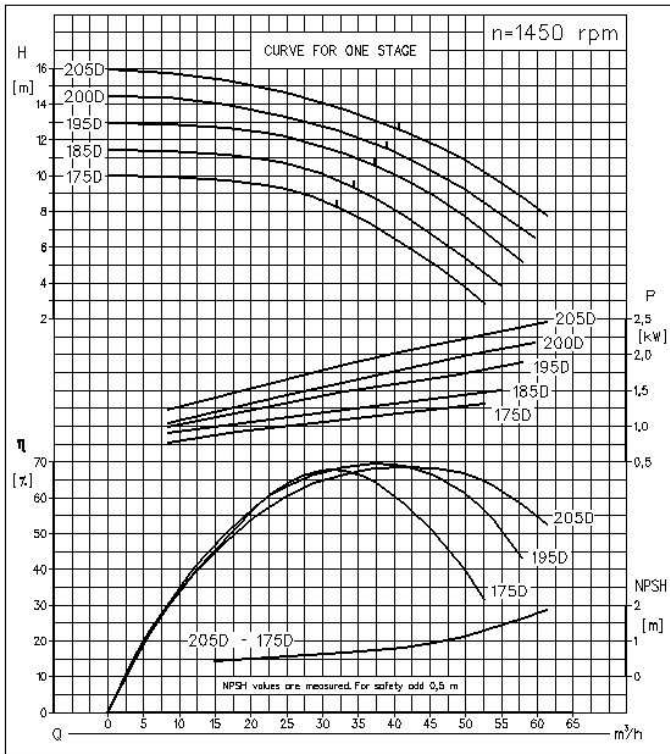

- Not valid for materials of construction 4B (stainless steel). Please consult with the factory.
- Head or Power for more than one stage = Head or Power for one stage multiplied by number of the stages.

Performance curves

HEGA 80

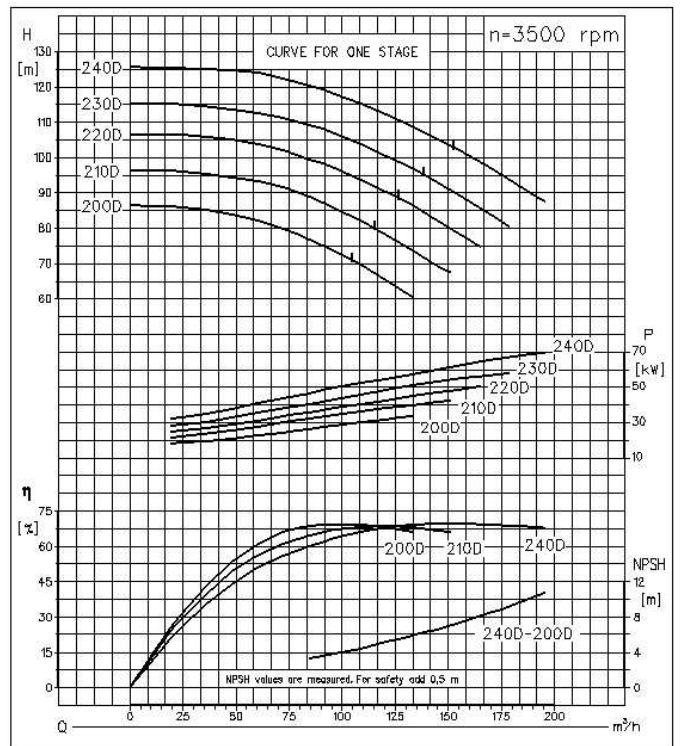
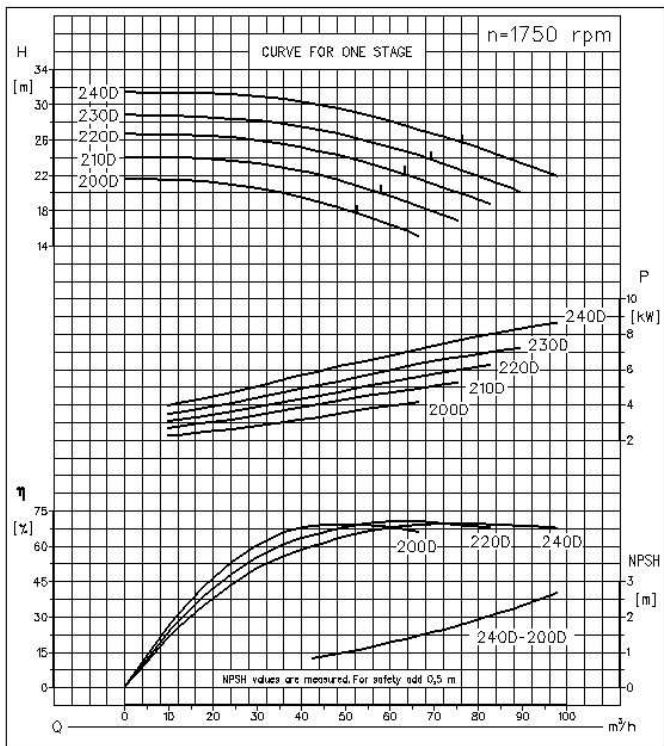
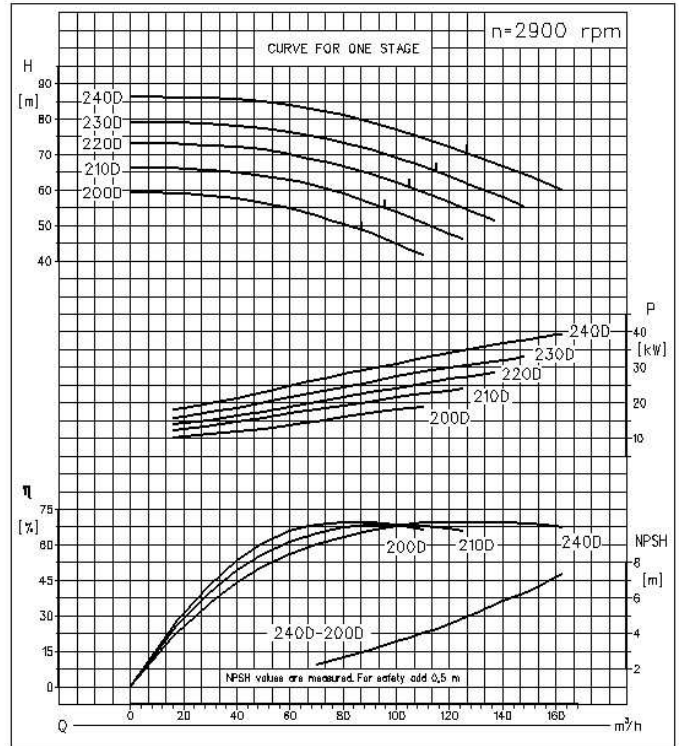
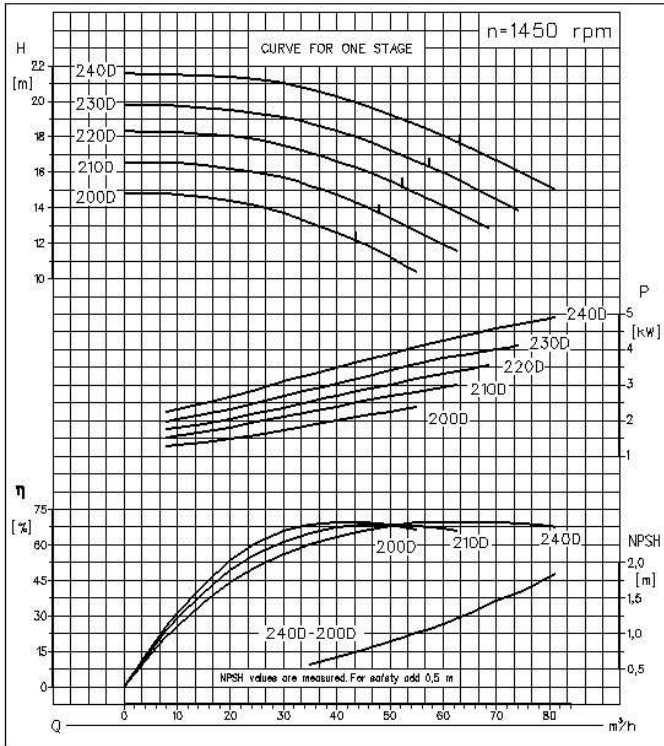

- Not valid for materials of construction 4B (stainless steel). Please consult with the factory.
- Head or Power for more than one stage = Head or Power for one stage multiplied by number of the stages.

Table of dimensions – shaft seal 001, BK3, BKS, BKU

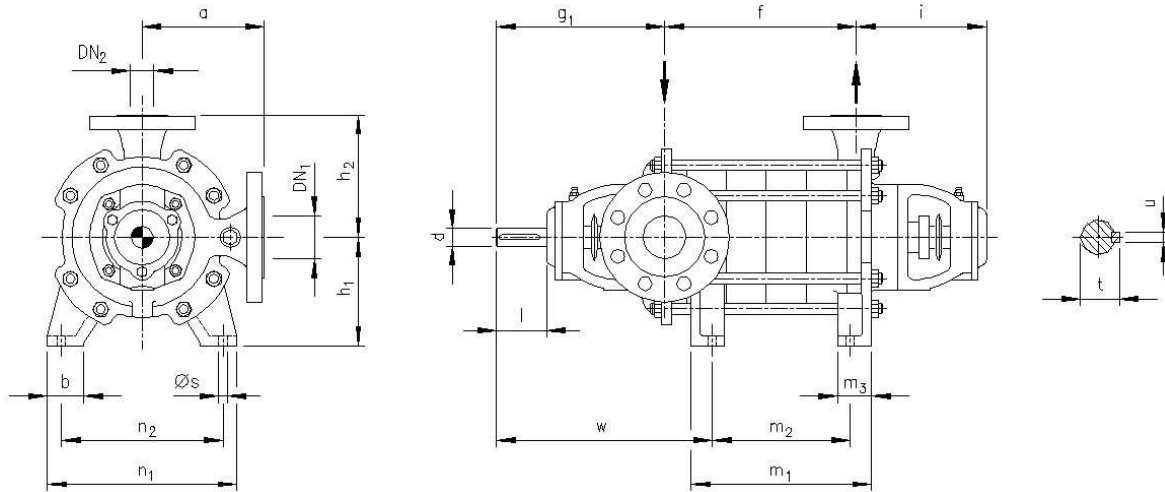

Pump size	DN ₂	DN ₁	Pump dimensions							Foot dimensions							Shaft end			
			a	f	g ₁	h ₁	h ₂	i	b	c	m ₁	m ₂	m ₃	n ₁	n ₂	s	w	d _{k6}	l	t
2500	32	40	160	According to Nr. of stages	243	132	160	173	45	12	According to Nr. of stages	45	250	216	15	293	28	60	30,9	8
3200		50			180	230	180									193				
4000	40	65	200		265	160	200	55	14	50		280	245	345	32	80	35,3			
5000	50	80	275		180	220	216	60	16	55		320	280	365						
6500	65	100	220		300	225	250	235	60	16		60	320	280	405	38	41,3			
8000	80	100	250		320	225	250	235	60	16		70	370	320	20			440		

Pump	2500			3200			4000			5000			6500			8000		
Nr.stg.	f	m ₁	m ₂	f	m ₁	m ₂	f	m ₁	m ₂	f	m ₁	m ₂	f	m ₁	m ₂	f	m ₁	m ₂
2 ⁽¹⁾	105	115	75	118	103	53	135	115	55	153	133	63	190	145	65	218	173	83
3	160	170	130	173	158	108	195	175	115	218	198	128	270	225	145	313	268	178
4	215	225	185	228	213	163	255	235	175	283	263	193	350	305	225	408	363	273
5	270	280	240	283	268	218	315	295	235	348	328	258	430	385	305	503	458	368
6	325	335	295	338	323	273	375	355	295	413	393	323	510	465	385	598	553	463
7	380	390	350	393	378	328	435	415	355	478	458	388	590	545	465	693	648	558
8	435	445	405	448	433	383	495	475	415	543	523	453	670	625	545	788	743	653
9	490	500	460	503	488	438	555	535	475	608	588	518	750	705	625	883	838	748
10	545	555	515	558	543	493	615	595	535	673	653	583	830	785	705			
11	600	610	570	613	598	548	675	655	595	738	718	648						
12	655	665	625	668	653	603	735	715	655									
13	710	720	680															

Flange dimensions according to DIN 2501						
DN ₂ / DN ₁	32	40	50	65	80	100
Ø D	140	150	165	185	200	220
Ø k	100	110	125	145	160	180
d ₂ x cant.	PN 16	18 x 4	18 x 4	18 x 4	18 x 4	18 x 8
	PN 40				18 x 8	-
Flange drilled according to ANSI B16.1 cl. 250						
DN ₂ / DN ₁	1,1/4"	1,1/2"	2"	2,1/2"	3"	4"
Ø k	98	114	127	149	168	200
d ₂ x cant.	19 x 4	22 x 4	19 x 8	22 x 8	22 x 8	22 x 8

(1) Suction flange vertically upwards only from three stages onward.

Table of dimensions – shaft seal 022⁽²⁾, 511, BX3, BXS, BXU

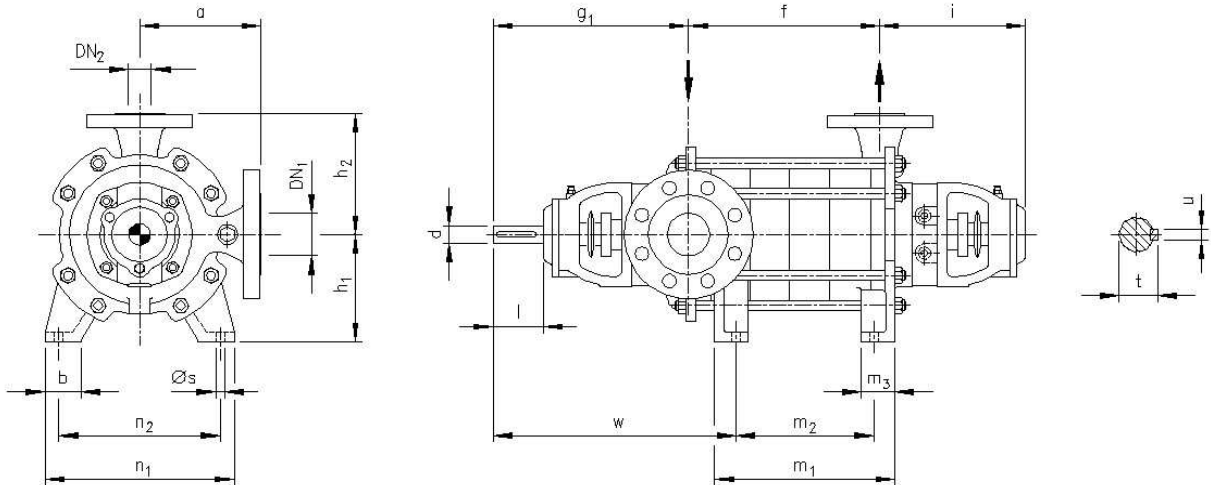

Pump size	DN ₂	DN ₁	Pump dimensions								Foot dimensions							Shaft end			
			a	f	g ₁	h ₁	h ₂	i	b	c	m ₁	m ₂	m ₃	n ₁	n ₂	s	w	d _{k6}	l	t	u
2500	32	40	160	According to Nr. of stages	298	132	160	228	45	12	According to Nr. of stages	45	250	216	15	348	28	60	30,9	10	
3200		50			180	285	160									180					350
4000	40	65	325		200	253		405													
5000	50	80	200		340	220	258	430													
6500	65	100	220		380	180	296	485													
8000	80	100	250		415	225	330	535													

Pump	2500			3200			4000			5000			6500			8000		
Nr.stg.	f	m ₁	m ₂	f	m ₁	m ₂	f	m ₁	m ₂	f	m ₁	m ₂	f	m ₁	m ₂	f	m ₁	m ₂
2 ⁽¹⁾	105	115	75	118	103	53	135	115	55	153	133	63	190	145	65	218	173	83
3	160	170	130	173	158	108	195	175	115	218	198	128	270	225	145	313	268	178
4	215	225	185	228	213	163	255	235	175	283	263	193	350	305	225	408	363	273
5	270	280	240	283	268	218	315	295	235	348	328	258	430	385	305	503	458	368
6	325	335	295	338	323	273	375	355	295	413	393	323	510	465	385	598	553	463
7	380	390	350	393	378	328	435	415	355	478	458	388	590	545	465	693	648	558
8	435	445	405	448	433	383	495	475	415	543	523	453	670	625	545	788	743	653
9	490	500	460	503	488	438	555	535	475	608	588	518	750	705	625	883	838	748
10	545	555	515	558	543	493	615	595	535	673	653	583	830	785	705			
11	600	610	570	613	598	548	675	655	595	738	718	648						
12	655	665	625	668	653	603	735	715	655									
13	710	720	680															

Flange dimensions according to DIN 2501						
DN ₂ / DN ₁	32	40	50	65	80	100
Ø D	140	150	165	185	200	220
Ø k	100	110	125	145	160	180
d ₂ x cant.	PN 16	18 x 4	18 x 4	18 x 4	18 x 4	18 x 8
	PN 40				18 x 8	-
Flange drilled according to ANSI B16.1 cl. 250						
DN ₂ / DN ₁	1,1/ 4"	1,1/ 2"	2"	2,1/ 2"	3"	4"
Ø k	98	114	127	149	168	200
d ₂ x cant.	19 x 4	22 x 4	19 x 8	22 x 8	22 x 8	22 x 8

(1) Suction flange vertically upwards only from three stages onward.

(2) Only sizes 4000, 5000, 6500, 8000.

Connections

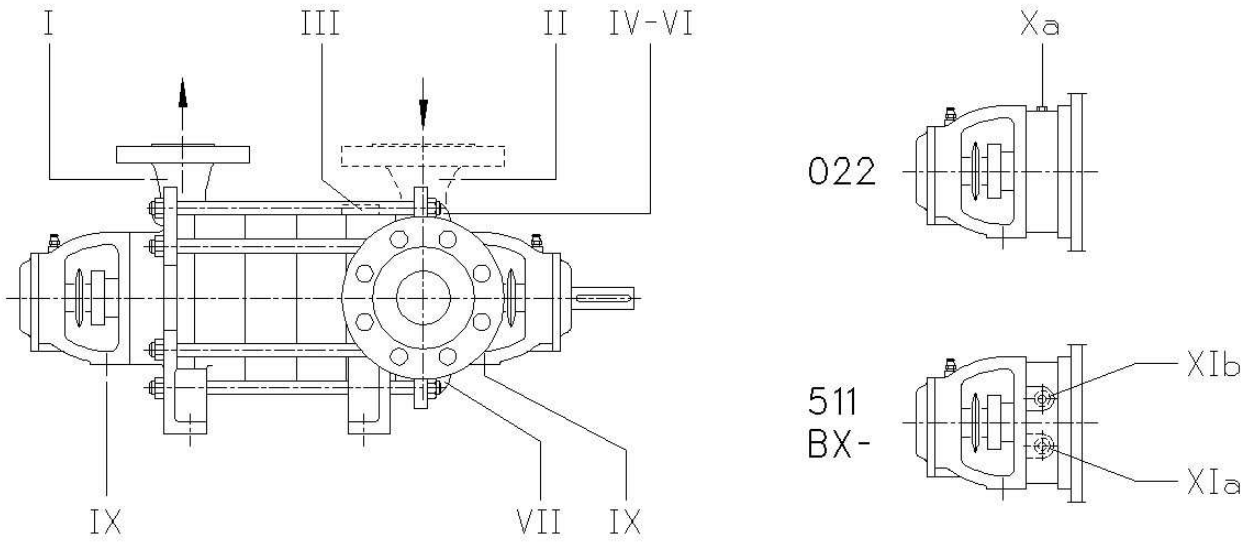

Code	Connections	Shaft seal	Position of connections	Dimensions	
				2500 - 5000	6500 - 8000
I	Pressure gauge connection	001 022 511 BK- BX-	Discharge flange	G1/2"	G1/2"
II	Pressure / vacuum gauge connection		Suction flange	G1/2"	G1/2"
III	Vent		First stage casing	G1/4"	G3/8"
IV ⁽¹⁾	Vent		Suction casing	G1/4"	G3/8"
VI ⁽¹⁾	Filler connection		Suction casing	G1/4"	G3/8"
VII	Drain		Suction casing	G1/4"	G3/8"
IX	Drip and leakage connection		Bearing suction (suction and discharge side)	G3/8"	G1/2"
Xa	Connection for sealing liquid	022	Stuffing box housing (suction and discharge side)	G3/8"	G1/2"
XIa	Inlet connection for shaft seal cooling	511 BX-	Stuffing box housing (suction and discharge side)	G3/8"	G1/2"
XIb	Outlet connection for shaft seal cooling		Stuffing box housing (suction and discharge side)	G3/8"	G1/2"

(1) When suction flange position is horizontal, to right or to left.

Denomination – Instructions for ordering

The table describes the codification for the pump denomination according to its execution.

Type, size and number of stages	Impeller combination	Hydraulic and shaft support	Shaft sealing	Materials of construction	Casing gasket	Drive, standard and orientation of the flanges (always seen from shaft end)
HEGA 02502 - 02513 03202 - 03212 04002 - 04012 05002 - 05011 06502 - 06510 08002 - 08009	0-4 0-4 0-4 0-7 0/9 0/9	A • Hydraulic A	001 Uncooled stuffing box.	0B Main parts in cast iron	P O-rings of NBR ⁽²⁾ (Perbunan)	DRIVE ON SUCTION SIDE: 0 DIN/EN flanges, discharge vertical up, suction horizontal right. 1 Same as 0, but suction horizontal left. 2 Same as 0, but suction vertical up. (only for more than 3 stages) A Same as 0, but flanges drilled according to ANSI. B Same as 1, but flanges drilled according to ANSI. C Same as 2, but flanges drilled according to ANSI. DRIVE ON DISCHARGE SIDE (only for sizes 25, 32 and 40): 3 DIN/EN flanges, discharge vertical up, suction horizontal left. 4 Same as 3, but suction horizontal right. 5 Same as 3, but suction vertical up. (only for more than 3 stages) D Same as 3, but flanges drilled according to ANSI. E Same as 4, but flanges drilled according to ANSI. F Same as 5, but flanges drilled according to ANSI.
		B • Hydraulic B ⁽¹⁾	022 Externally flushed, uncooled, lengthened stuffing box (only for sizes 40, 50 and 65).	0C Same as 0B but impellers in bronze	V O-rings of FKM ⁽²⁾ (Viton)	
		• B One cylindrical roller bearing (DIN 5412) on the suction side and one deep-groove ball bearing (DIN 625) on the discharge side; both lubricated by grease.	511 Cooled stuffing box.	0D Same as 0C but diffusers and wear rings in bronze		
		• S One cylindrical roller bearing (DIN 5412) on the suction side and one four-point contact ball bearing (DIN 628) or two single row angular contact ball bearings mounted in X arrangement on the discharge side; both lubricated by grease.	BK3 Unbalanced single mechanical seal with rubber bellows and self-circulation.	0E Same as 0B but impellers in stainless steel		
			BKU	0R Same as 0B but shaft in stainless steel		
			BKS	0S Same as 0C but shaft in stainless steel		
			BX3 Equivalent to BK3/BKS/BKU plus refrigeration or heating chamber	0U Same as 0E but shaft in stainless steel		
			BXU	4B Main parts of stainless steel		
			BXS			

(1) Only size 3200

(2) Shortway according to ISO 1629

Example of order:

For pump size HEGA 32 of 6 stages with 2 trimmed impellers, strengthened shaft support, cooled stuffing box shaft sealing,

impellers of bronze, o-rings of Viton and DIN/EN flanges vertical up: **HEGA 3206/2 BS.511.0C.V2**

SIHI Pumps Colombia reserves the right to make any change on this document without previous notice



SIHI Pumps Colombia

Cra. 34 A Nr. 4 - B - 33 - Bogotá D.C., Colombia
Tel. (57-1) 3649264 - Fax. (57-1) 3649262 - 3649241
E-mail: info@sihi.com.co

www.sihi.com.co

SIHI HALBERG *LaBour* SERVICE

Brands of the Sterling Fluid Systems Group

www.sterlingsihi.com