

***Worcester Controls AW44  
3-Piece Steam Isolation Valve***



***Experience In Motion***

In the AW44, Flowserve Worcester has recognised the need for a 3-piece ball valve specifically designed for the isolation of steam. With energy costs already high and still rising, the AW44 has proved itself to be cost effective in minimising the loss of process steam.

Using its unique Fluorofill seat material, Worcester guarantees the AW44 on continuous saturated steam service up to 250 psi. (17 bar) whilst other Worcester high performance seat materials provide even higher temperature/pressure capabilities. In addition to its proven record with steam as a heat transfer

medium, the AW44 can accommodate other thermal fluids/hot oils up to 250°C (Fluorofill), or up to 280°C where required with other seat materials.

The AW44 features a mounting platform on the body for ease of ancillary mounting while retaining valve integrity.

For these demanding duties, Worcester incorporates its unique PTFE-coated metal body seal which maintains its sealing capability during thermal cycling.

Available in sizes 8-50 mm, the AW44 is manufactured in carbon steel and stainless steel with a range of end connections.

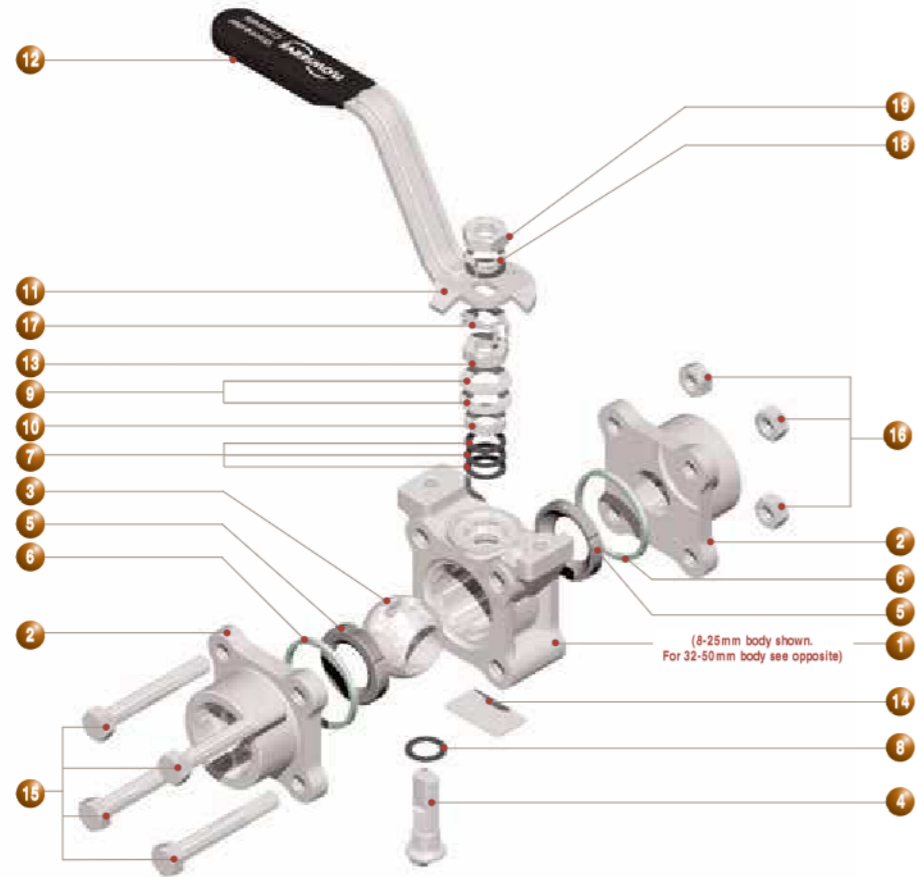

### Parts/Materials List

ITEM	DESCRIPTION	MATERIAL	ITEM	DESCRIPTION	MATERIAL
1.	Body	Carbon Steel ASTM A216WCB Stainless Steel ASTM A351 CF8M UNS J92900	11.	Wrench	Carbon Steel Rustproofed / Stainless Steel 304
2.	Body Connector	Carbon Steel ASTM A216WCB / A105 Stainless Steel ASTM A351 CF8M	12.	Wrench Sleeve	Vinyl Plastisol
3.	Ball (See Note 7)	Stainless Steel ASTM A351 CF8M UNS J92900	13.	Gland Nut	Stainless Steel 316
4.	Stem	Stainless Steel AISI Type 316	14.	Identification Plate	Stainless Steel 304
5.*	Seat Ring (See Note 5)	Fluorofill / PEEK	15.	Body Connector Bolt	Carbon Steel BS3692 Gr. 8.8 / Stainless Steel B6105/ISO 3506 A40-80
6.*	Body Connector Seal	Stainless Steel PTFE Coated	16.	Body Connector Nut	Carbon Steel BS3692 Gr. 8.8 / Stainless Steel B6105/ISO 3506 A40-80
7.*	Gland Packing	PTFE 35% Carbon Filled	17.	Gland Nut Locking Clip	Coated Spring Steel
8.*	Stem Thrust Seal	PTFE 35% Carbon Filled	18.	Spring Washer	Stainless Steel 316
9.*	Disc Spring	Stainless Steel	19.	Wrench Nut	Stainless Steel 316
10.	Gland	Stainless Steel 316			

\* Items marked thus denote component supplied in repair kit

### Features

- Mounting platform on valve body.
- PTFE coated metal body seal.
- Carbon-filled PTFE stem seals.
- Black wrench sleeve.
- Compact size.
- Lightweight.
- 3-piece design.
- High cranked handle
- Live loaded Gland

### Benefits

- Improved stem cycle life.
- Optimum performance during thermal cycling.
- Leak tight high cycling capability.
- Clear visual indication of AW44.
- Takes less space.
- Minimises need for pipe supports.
- Ease of maintenance.
- Enables pipeline insulation without the need for stem extension
- Reduced maintenance, increasing safety & line integrity.

Note: Main drawings below show 8-25mm body.  
See inset drawing for 32-50mm

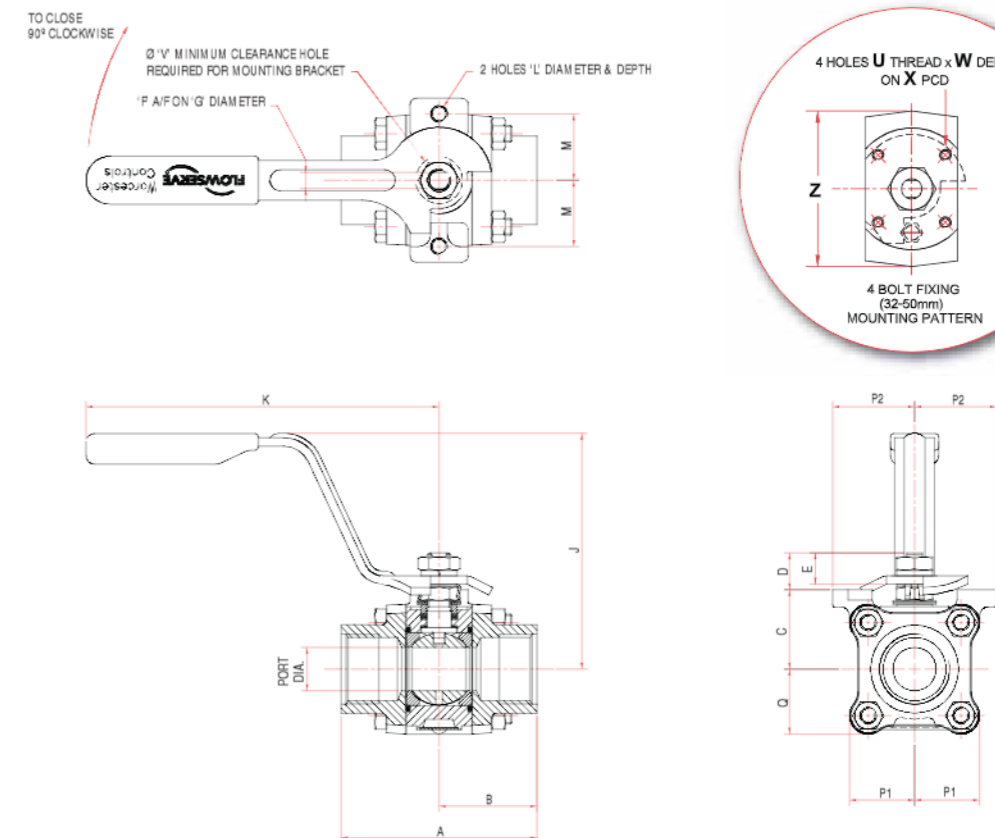

### Valve Dimensions (mm)

Valve Size (mm)	Port Dia.	A	B	C	D	E	F A/F	G THREAD	J	K	L THREAD & DEPTH	M	P1	P2	Q	Ø V	MOUNTING PLATFORM (BS EN ISO 5211) ISO MOUNTING HOLES PLATFORM RECESS	APPROX WEIGHT KG		
8, 10, 15	10.9	66.25 64.52	32.69	26.7 26.5	11.68 11.04	10.69 10.19	5.54 5.46	3/8"-24 UNF	97.9	156.0	M6 x 1.0p 9.5 MIN.	24.0	23.8	30.4	23.8	19.5	-	-	0.7	
20	14.0	71.81 70.09	35.48	29.1 28.9	11.68 11.04	10.69 10.19	5.54 5.46	3/8"-24 UNF	100.3	156.0	M6 x 1.0p 9.5 MIN.	27.0	27.2	33.4	27.2	19.5	-	-	0.9	
25	20.4	94.55 92.82	46.84	38.1 37.9	17.94 17.16	15.19 14.69	7.54 7.47	7/16"-20 UNF	112.8	169.0	M8 x 1.25p 9.7 MIN.	31.75	32.7	40.5	32.7	22.5	-	-	1.6	
32	25.1	106.90 105.17	53.02	37.10 36.85	23.74 22.91	15.19 14.69	15.19 14.69	7/16"-20 UNF	17.6	169.0	M5 x 0.8p 6.0 MIN.	19.5	36.3	-	36.3	22.5	F04	4 OFF M5 x 0.8p X 7.5 DEEP MIN. ON 42.0 P.C.D.	Ø 30.15 / 30.02 x 4.29 / 3.52 DEEP	2.2
40	31.3	115.41 113.69	57.28	44.00 43.75	29.55 28.73	18.39 17.89	18.39 17.89	9/16"-18 UNF	128.9	193.0	M6 x 1.0p 7.5 MIN.	23.0	42.3	-	42.3	29.5	F05	4 OFF M6 x 1.0p X 8.7 DEEP MIN. ON 50.0 P.C.D.	Ø 35.15 / 35.02 x 4.01 / 3.26 DEEP	3.2
50	37.7	127.94 126.21	63.54	48.75 48.50	29.55 28.73	18.39 17.89	18.39 17.89	9/16"-18 UNF	133.6	193.0	M6 x 1.0p 8.7 MIN.	23.0	47.4	-	47.4	29.5	F05	4 OFF M6 x 1.0p X 8.7 DEEP MIN. ON 50.0 P.C.D.	Ø 35.15 / 35.02 x 4.01 / 3.26 DEEP	4.3

### Pressure Temperature Ratings

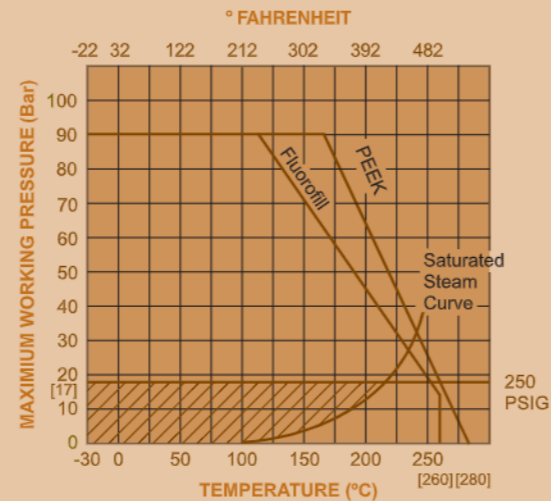

### Notes

1. Screwed butt weld and socket weld end variations are available
2. Limiting stem input torque figures are based on random practical laboratory tests. For critical applications where a guaranteed figure is essential consult Worcester Controls.
3. When wrench not fitted flats on stem, when parallel to pipeline axis, denote ball open.
4. All weld end valves are assembled with Buna 'O' ring body connector seals with body seals attached loose. This provides for the valve to be tested by Worcester Controls, disassembled by the customer to weld in line, and reassembled. Instructions will be supplied for fitting body seals.
5. Other seat variations are available.
6. All valves have stainless steel trim as standard.
7. Installation, Operating and Maintenance Instructions are available on request.
8. Specially prepared versions of this valve are available which comply to NACE-MR-01-75.

### Flow Coefficients

Valve Size		Flow Coefficients		Equivalent Length of Pipe	
mm	in	Cv	Kv	Feet	Metres
8-15	¼-½	8.3	7.2	1.9	0.58
20	¾	13.6	11.8	5.5	1.67
25	1	37.5	32.6	3.0	0.91
32	1¼	37.7	32.7	4.6	1.4
40	1½	79.5	69.1	3.9	1.19
50	2	106	92	9.0	2.74

### Standards of Compliance

<b>Butt Weld Valves</b>	Weld Preparation: SCH 40 & 10: BS 2633 suitable for Schedule Pipe to BS 1600
<b>Socket Weld Valves</b>	Prepared for assembly to plain end pipe in accordance with BS 1600
<b>Screwed Valves</b>	Thread Specification: BSP Taper - ISO/7 BS 21 BSP Parallel - BS 2779/ISO 228/1 ISO/7 (BS 21 DIN 2999) NPT- ANSI B1.20.1
<b>Test Rating</b>	Valves are tested to the pressures and durations as defined in BS 6755 Part 1

FCD WCEBR0009-01 Printed in Germany. (Replaces PB07 Rev 12/02)

#### To find your local Flowserve representative:

For more information about Flowserve Corporation,  
visit [www.flowserve.com](http://www.flowserve.com) or call +44 (0) 1444 314400

Due to continuous development of our product range, we reserve the right to alter the dimensions and information contained in this leaflet as required. Information given in this leaflet is made in good faith and based upon specific testing but does not, however, constitute a guarantee.

### Options



Critical in applications such as steam isolation, the Worcester Lockable Wrench is a standard option for the AW44 in any size. If you need to ensure valve position integrity, this option provides the perfect solution.



**Flowserve Flow Control**  
A Division of Flowserve GB Ltd  
Burrell Road, Haywards Heath  
West Sussex RH16 1TL  
United Kingdom  
Telephone: +44 (0)1444 314400  
Telefax: +44 (0)1444 314401  
Email: [wvukinfo@flowserve.com](mailto:wvukinfo@flowserve.com)