

IMI PBM SANITARY CHECK VALVES

VC and HC SERIES, 1/2" - 4"



DESIGN FEATURES:

- Check valves use no internal springs nor guides.
- Vertical and horizontal valves are split body design using sanitary clamp and USP Class VI gasket
- All materials are FDA compliant
- Elastomers are USP Class VI compliant
- Extended butt weld in 316L material has 0.005 to 0.017% sulfur control
- Valve body includes marking designating direction of flow
- Applications are liquid, low pressure steam
- Report (MTRS) provided for wetted components
- Surface finishes are achieved without the use of ADIs (Animal Derived Ingredients)



SPECIFICATIONS	CHECK VALVES
Sizes	1/2" - 4"
Material	316L, Hastelloy™ C276/22, AL6XN™, others
Temperatures	-10°F to 300°F
End Connections	Sanitary clamp or extended butt weld for U.S. gauge tubing
Cold Working Pressure	Up to 2" (full vacum to 235 psig), 2-1/2" to 3" (full vacum to 150 psig), 4" (full vacuum to 100 psig)
Maximum Working Pressure	Rated up to 300°F saturated steam at 55 psig
Crack Pressure	0.1 psig, 1/2" - 2", 0.24 psig, 2-1/2" - 4"
Polish	Standard internal polish of 20 Ra or better

CV Values (gpm)		
Size		Vertical/ Horizontal
1/2"	DN 15	2.3
3/4"	DN 20	6.2
1"	DN 25	13
1-1/2"	DN 40	29
2"	DN 50	51
2-1/2"	DN 65	72
3"	DN 80	95
4"	DN 100	170

Component	Material	Specification
Body, End (VC & HC)	316L Stainless steel	Bar Stock: A479, S31603
	Hastelloy® C-276	Bar Stock: B574, N10276
	AL6XN®	Bar Stock: B691, N08367
	Hastelloy® C-22®	Bar Stock: B574, N06022
Poppet	PTFE	Virgin PTFE, USP Class VI
Body Clamp gasket	Viton, PTFE, EPDM	USP Class VI
Body Clamp	304 Stainless Steel	CF8 or F304

Testing: Maximum Allowable Leakage Rates

Size	PTFE Poppet
1/2", 3/4", 1"	5 drops/min @ 3 psi (.2 bar)
1-1/2"	8 drops/min @ 3 psi (.2 bar)
2"	10 drops/min @ 3 psi (.2 bar)
2-1/2" - 3"	15 drops/min @ 3 psi (.2 bar)
4"	20 drops/min @ 3 psi (.2 bar)

Component	ID Finish	OD Finish	Type
Body, End*	20 Ra max	63 Ra max	Standard finish, Mechanical
PTFE poppet	-	-	Standard finish, Mechanical

*Optional finer finishes and electropolish available

How To Order:

Product Style (1-2)	Materials (3-4)	Size (5)	Upstream End Connection (6)	Downstream End Connection (7)	Poppet & Gasket (8)	Polish (9) (Mech. unless noted)	Miscellaneous (10)
HC HORIZONTAL CHECK VALVE	HL 316L Stainless	C 1/2"	F Ext tube butt weld	- Same as Upstream	C PTFE / PTFE	A 20Ra ID (STD)	- No Options
	C- Hastelloy® C-276	D 3/4"	X clamp - tube	F Ext tube butt weld	S PTFE / FKM	B 32Ra OD	L LOX cleaning per PBM Procedure
VC VERTICAL CHECK VALVE	Y- Hastelloy® C-22®	E 1"		X clamp - tube	T PTFE / EPDM	C 20Ra ID / 32Ra OD	
	P- AL6XN	G 1-1/2"				D 15Ra ID	
		H 2"				E 10Ra ID	
		J 2-1/2"				F 20Ra ID after EP	
		K 3"				G 15Ra ID after EP	
		L 4"				H 10Ra ID after EP	
					I 5Ra ID		
					K 5Ra ID / 32Ra OD		
					L 20Ra ID / 32Ra OD / EP		
					M EP ID & OD		
					N 10Ra ID / 32Ra OD		
					O 15Ra ID / 32Ra OD / EP		
					Q 15Ra ID / 32Ra OD		
					S 10Ra ID / 32Ra OD / EP		

<http://pbmvalve.com/build-a-part-number>

IMI PBM SANITARY CHECK VALVES

VERTICAL CHECK VALVES

Valve Size	ID		OD Butt weld Ends		L			
	inches	mm	inches	mm	X- Clamp		F- Weld	
					inches	mm	inches	mm
1/2" DN 15	0.37	9.4	0.50	12.7	2.25	57.2	5.25	133.4
3/4" DN 20	0.62	15.7	0.75	19.1	2.50	63.5	5.50	139.7
1" DN 25	0.87	22.1	1.00	25.4	2.75	69.9	5.75	146.1
1-1/2" DN 40	1.37	34.8	1.50	38.1	3.50	88.9	6.50	165.1
2" DN 50	1.87	47.5	2.00	50.8	4.00	101.6	7.00	177.8
2-1/2" DN 65	2.37	60.2	2.50	63.5	6.50	165.1	10.00	254
3" DN 80	2.87	72.9	3.00	76.2	6.50	165.1	10.00	254
4" DN 100	3.83	97.3	4.00	101.6	7.50	190.5	11.50	292.1

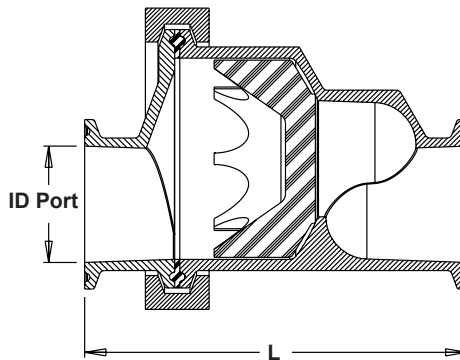
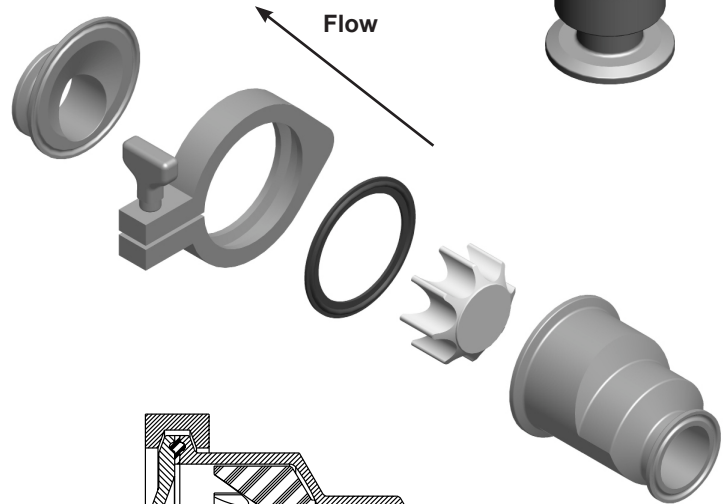
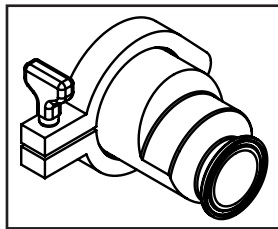
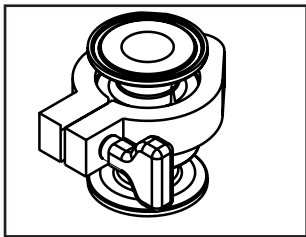
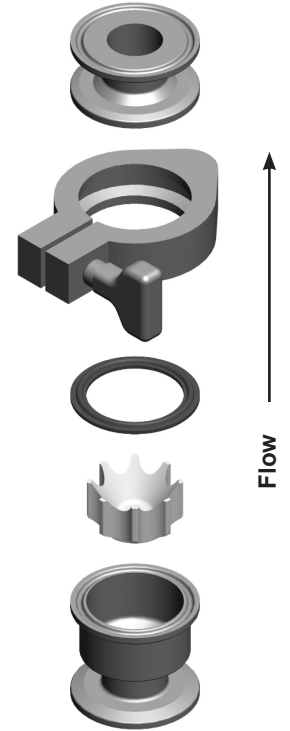
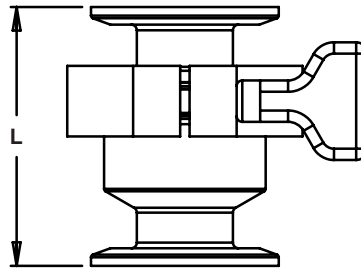

HORIZONTAL CHECK VALVES

Valve Size	ID		OD Butt weld Ends		L			
	inches	mm	inches	mm	X- Clamp		F- Weld	
					inches	mm	inches	mm
1/2" DN 15	0.37	9.4	0.50	12.7	2.75	69.9	5.75	146.1
3/4" DN 20	0.62	15.7	0.75	19.1	3.50	88.9	6.50	165.1
1" DN 25"	0.87	22.1	1.00	25.4	3.50	88.9	6.50	165.1
1-1/2" DN 40	1.37	34.8	1.50	38.1	4.50	114.3	7.50	190.5
2" DN 50"	1.87	47.5	2.00	50.8	5.50	139.7	8.50	215.9
2-1/2" DN 65	2.37	60.2	2.50	63.5	9.50	241.3	13.00	330.2
3" DN 80	2.87	72.9	3.00	76.2	9.50	241.3	13.00	330.2
4" DN 100	3.83	97.3	4.00	101.6	11.00	279.4	15.00	381.0