



Worcester Controls F44 Anti-Static Firesafe 3-Piece Ball Valves



Experience In Motion

The Series F44 is a fire-safe variant of the renowned Flowserve Worcester three-piece range of ball valves. It has been fire-tested in accordance with ISO 10497 and features graphite gland and body seals, 8 high tensile body connector screws for strength in fire conditions, and an integral location spigot machined on the body connector to ensure correct alignment of the fire lip to the ball in a fire.

The design of the valve is such that graphite contamination of the media is now a thing of the past. Further benefits of this product include a mounting platform on the body for ease of ancillary mounting whilst retaining valve integrity, the three-piece valve's inherent ease of maintenance and its compact and lightweight design. The F44 is available in sizes 8-50mm in a range of materials and with a variety of end connections.

The F44 is fully PED (Pressure Equipment Directive) approved (97/23/EC).

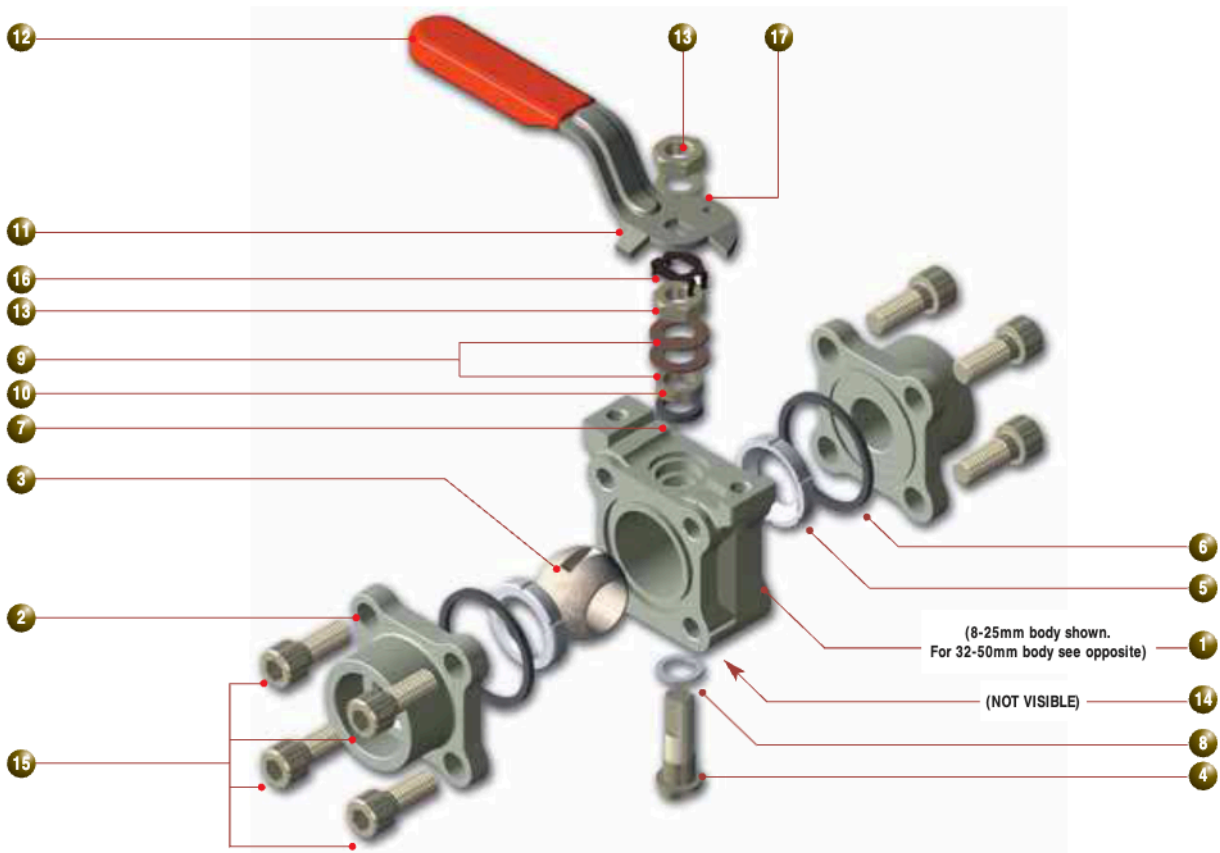

Parts/Materials List

ITEM	DESCRIPTION	MATERIAL	ITEM	DESCRIPTION	MATERIAL
1.	Body	Carbon Steel ASTM A105 (UNS K03504) Stainless Steel A351 CF8M (UNS J92900)	11.	Wrench	Carbon Steel Rustproofed / Stainless Steel
2.	Body Connector	Carbon Steel ASTM A105 (UNS K03504) Stainless Steel A351 CF8M (UNS J92900) CF3M (UNS J92800)	12.	Wrench Sleeve	Vinyl Plastinol
3.	Ball	Stainless Steel ASTM A479 316 (UNS S31600) or ASTM A351 CF8M (UNS J92900)	13.*	Gland Nut	Stainless Steel
4.	Stem	Stainless Steel 316	14.	Identification Plate	Stainless Steel
5.*	Seat Ring (See Note 5)	PTFE Virgin / 15% Glass Filled	15.	Body Connector Screw	Stainless Steel BS 4882 B8MX
6.*	Body Connector Seal	PTFE Coated Graphite	16.*	Gland Nut Locking Clip	Spring Steel Rustproofed
7.*	Gland Packing	Graphite	17.*	Spring Washer	Coated Spring Steel
8.*	Stem Thrust Seal	PTFE 35% Carbon Filled	* Items marked thus denote component supplied in rear kit		
9.*	Disc Spring	Stainless Steel			
10.	Gland	Stainless Steel			

Features

- Graphite gland and body seals.
- Mounting platform on valve body.
- Metal to metal ball / fire lip seal.
- 8 high tensile bolts.
- Compact size.
- Lightweight.
- 3-piece design.

Benefits

- For optimum valve integrity before and after a fire.
- Improved stem cycle life.
- To minimise leakage through the valve.
- Maintains integrity of pressure vessel during fire.
- Takes less space.
- Minimises need for pipe supports.
- Ease of maintenance.

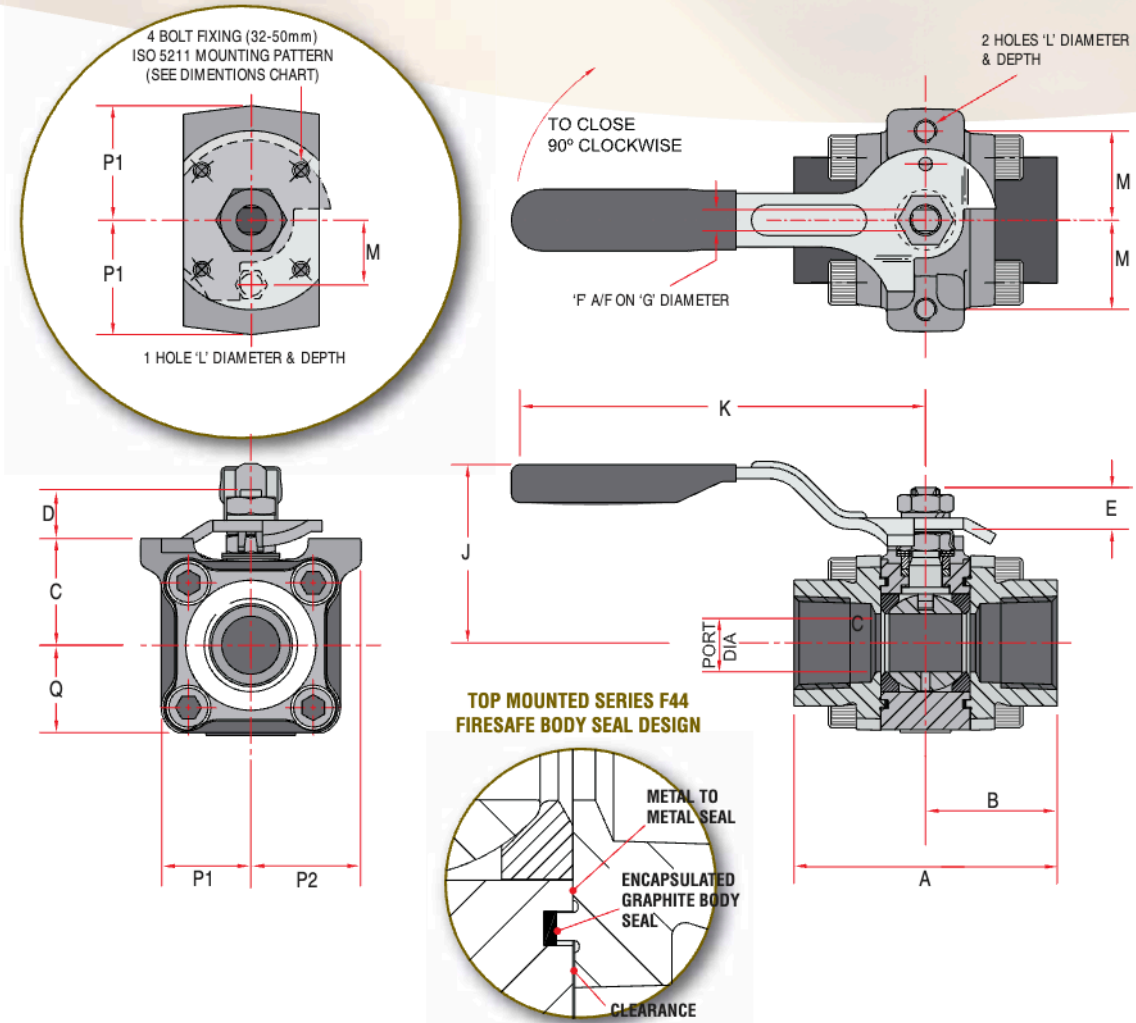

Valve Dimensions (mm)

Note: Main drawings show 8-25mm body.
See inset drawing for 32-50mm

Valve Size (mm)	Port Ø MIN.	A	B	C	D	E	STEM		J	K	L Thread & Depth	M	P1	P2	Q	Mounting Platform (BS EN ISO 5211)		Approx. Weight Kg
							F A/F	G THREAD								ISO SIZE	Mounting Holes	
8-15	10.9	66.25	32.69	26.7	11.68	10.69	5.54	3/8"-24 UNF	57.9	136.0	M6 x 1.0P 9.5 MIN.	24.0	23.8	30.4	23.8			0.7
		64.52		26.5	11.04	10.19	5.46											
		71.81		29.1	11.68	10.69	5.54											
20	14.0	70.09	35.48	28.9	11.04	10.19	5.46	3/8"-24 UNF	60.3	136.0	M6 x 1.0P 9.5 MIN.	27.0	27.2	33.4	27.2			0.9
		94.55		38.1	17.94	15.19	7.54											
25	20.4	92.82	46.84	37.9	17.16	14.69	7.47	7/16"-20 UNF	64.8	149.0	M8 x 1.25P 9.7 MIN.	31.75	32.7	40.5	32.7			1.6
		106.90		37.10	23.74	15.19	7.54											
32	25.1	105.17	53.02	39.85	22.91	14.69	7.47	7/16"-20 UNF	69.6	149.0	M5 x 0.8P 6.0 MIN.	19.5	36.3	36.3	F04	4 OFF M5 x 0.8p X 7.5 DEEP MIN. ON 42.0 P.C.D	Ø 30.15 / 30.02 x 4.29 / 3.52 DEEP	2.2
		115.41		44.00	29.55	18.39	8.71											
40	31.3	113.69	57.28	43.75	28.73	17.89	8.64	9/16"-18 UNF	82.6	181.0	M6 x 1.0P 7.5 MIN.	23.0	42.3	43.2	F05	4 OFF M6 x 1.0p X 8.7 DEEP MIN. ON 50.0 P.C.D	Ø 35.15 / 35.02 x 4.01 / 3.26 DEEP	3.2
		127.94		48.75	29.55	18.39	8.71											
50	37.7	126.21	63.54	48.50	28.73	17.89	8.64	9/16"-18 UNF	82.6	181.0	M6 x 1.0P 8.7 MIN.	23.0	47.4	47.4	F05	4 OFF M6 x 1.0p X 8.7 DEEP MIN. ON 50.0 P.C.D	Ø 35.15 / 35.02 x 4.01 / 3.26 DEEP	4.3

Pressure Temperature Ratings

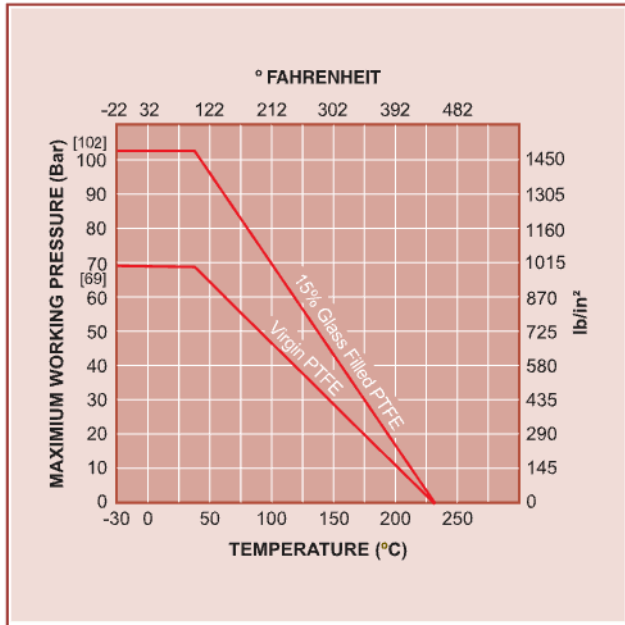

Notes

- Screwed ends shown for clarity. Butt weld and socket weld variations are available.
- Limiting stem input torque figures are based on random practical laboratory tests. For critical applications where a guaranteed figure is essential consult Worcester Controls.
- When wrench not fitted flats on stem when parallel to pipeline axis, denotes ball in open position.
- All weld end valves are assembled with Buna 'O' ring body connector seals with fire seals attached loose. This provides for the valve to be tested by Worcester Controls, disassembled by the customer to weld in line, and reassembled. Instructions will be supplied for fitting fire seals.
- Other seat variations are available.
- Stainless steel valves have stainless steel trim as standard.
- Installation, Operating and Maintenance Instructions are supplied with each order.
- Specially prepared versions of this valve are available which comply to NACE-MR-01-75.

Flow Coefficients

Valve Size		Flow Coefficients		Equivalent Length of Pipe	
mm	in	Cv	Kv	Feet	Metres
8-15	½	8	6.9	1.9	0.58
20	¾	12	10.4	5.5	1.67
25	1	32	28.1	3	0.91
32	1¼	46	39.8	3.1	0.94
40	1½	80	69.2	3.9	1.19
50	2	104	90.0	7.5	2.28

Cv – Flow in US GPM Pressure – psi
Kv – Flow in M³/hr Pressure – bar

How to order Worcester Valves and other Worcester products

Please order Worcester Valves and other products by description, not by part number.

We need a precise description of the valve you require. We will then translate this information into our own coding for order processing and production.

Please state the despatch address and desired date of delivery.

WCEBR0014-01 Printed in Germany. (Replaces PB06)

To find your local Flowserve representative:

For more information about Flowserve Corporation, visit www.flowserve.com or call USA 1 800 225 6989

Due to continuous development of our product range, we reserve the right to alter the dimensions and information contained in this leaflet as required. Information given in this leaflet is made in good faith and based upon specific testing but does not, however, constitute a guarantee.

Standards of Compliance

Butt Weld Valves	Weld Preparation: BS 2633 suitable for Schedule 5, 10 & 40 Pipe to BS 1600 & API 5L
Socket Weld Valves	Prepared for assembly to plain end pipe in accordance with BS 1600, BS3600 & API 5L
Screwed Valves	Thread Specification: BSP Taper - ISO/7 BS 21 BSP Parallel - BS 2779/ISO 228/1 DIN 2999 NPT- ANSI B1.20.1.
Firesafe Specification	In accordance with ISO 10497:2004
Test Rating	Valves are subjected to the requirements of EN 12266 Part 1 with hydrostatic Shell test.

Limiting Stem Input Torque

Valve Size		Limiting Stem Input Torque		See Note 2
mm	in	lb/ft/in	Nm	
8-20	¼-¾	117	13.2	
25-32	1-1¼	216	24.4	
40-50	1½-2	430	48.6	



Flowserve Flow Control (UK) Ltd.

Worcester Controls
Burrell Road, Haywards Heath
West Sussex RH16 1TL
United Kingdom
Telephone: +44 (0)1444 314400
Telefax: +44 (0)1444 314401
Email: wvukinfo@flowserve.com