



***Worcester Controls 3HP44/5HP44  
High Pressure 3-Piece Ball Valve***



*Experience In Motion*

Flowserve Worcester's 3HP44/5HP44 was developed specifically for use in high pressure systems. Typically handling oil, inhibited water or nitrogen gas.

The 3HP44/5HP44 is derived from Worcester's proven Series 44 3-piece valve, and incorporates a number of enhanced product features, all designed to optimise the valve's performance. These include high pressure seals, thicker flanges on the body connectors, high tensile bolting, special high pressure acetal resin or PEEK seats and a high strength stem.

Compared with other types of high pressure valves, the 3HP44/5HP44 offers greater flow rates and easier operation (whether manual or automated).

Whilst acetal resin seats will tolerate temperatures up to 80°C the use of PEEK seats extends the valve's temperature capability to 170°C, in conjunction with appropriate stem and body seals (see graph for corresponding pressures).

The 3HP44/5HP44 is manufactured in carbon and stainless steel in sizes ranging from 8 to 50mm, with body connector options including screwed, butt weld and socket weld.

### PED Compliance

Valve Size mm	Valve Size in	Prefix	Maximum Pressure	Media
8 - 25	¼ - 1	5HP	5000psi	Liquids or Gases
32 - 50	1¼ - 2	5HP	5000psi	Group II Liquids
32 - 50	1¼ - 2	3HP	3000psi	Liquids or Gases

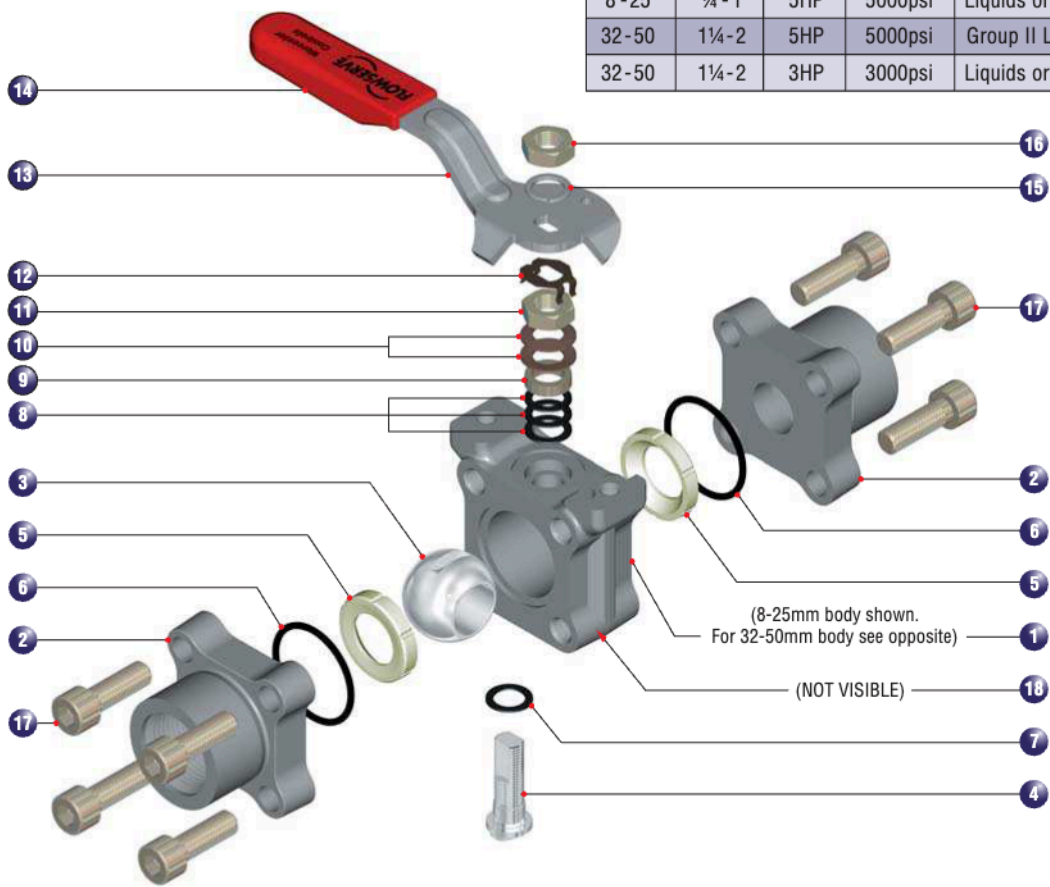

### Parts / Materials List

ITEM	DESCRIPTION	MATERIAL	ITEM	DESCRIPTION	MATERIAL
1	Body	Stainless Steel ASTM A182 F316 (UNS S31600) or Carbon Steel ASTM A479 316 (UNS S31600) ASTM A105 (UNS K03504)	9	Gland	Stainless Steel
2	Body Connector	Stainless Steel ASTM A479 316 (UNS S31600) 0.03% Carbon Maximum or Carbon Steel ASTM A105 (UNS K03504) 0.2% Carbon Maximum	10*	Disc Springs	Stainless Steel
3	Ball	Stainless Steel ASTM A479 316 (UNS S31600) or ASTM 351 CF8M (UNS J92900)	11*	Gland Nut	Stainless Steel
4	Stem	Stainless Steel ASTM A564 Type 630 - H900 (UNS S17400)	12*	Locking Clip	Carbon Spring Steel
5*	Seat Ring	Acetal Resin (Delrin) / PEEK	13	Wrench	Carbon Steel / Iron
6*	Body Seal (O-Ring)	Nitrile Rubber / Viton 'A'	14	Wrench Sleeve	Vinyl Plastisol
7*	Stem Seal	Nylatron / PEEK	15*	Spring Washer	Stainless Steel
8*	Gland Packing	PTFE 35% Carbon Filled	16	Wrench Nut	Stainless Steel
			17	Hexagon Socket Head Cap Screw	Carbon Steel
			18	Identification Plate	Stainless Steel

**Notes:** Valve sizes 40-50mm have a stop plate, stop pin and cast iron wrench. Valve size 32mm has a stop pin.

\* Items marked thus denote component supplied in repair kit

## Features

- 3-piece design
- Quarter turn design
- Wide range of body connectors
- Bottom entry stem
- High tensile stem
- Nylatron / PEEK thrust seal
- High tensile cap-head screws

## Benefits

- Ease of maintenance
- Quick and easy operation
- Greater pipe connection choice
- Blow-out proof safety
- Greater operational reliability
- Maximum stem integrity
- High pressure integrity

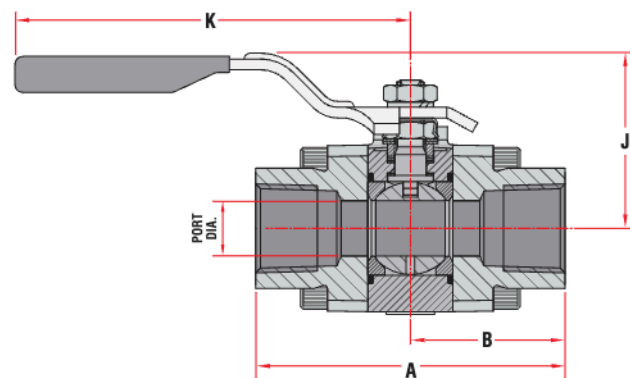
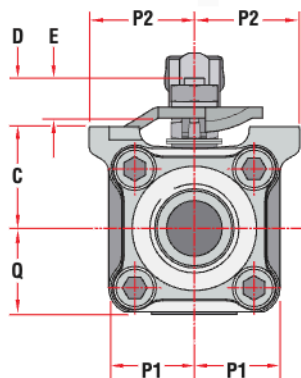
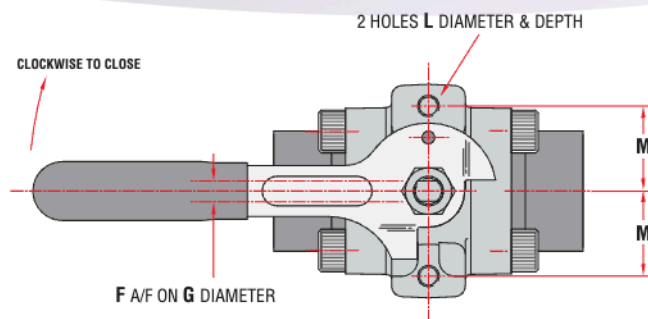
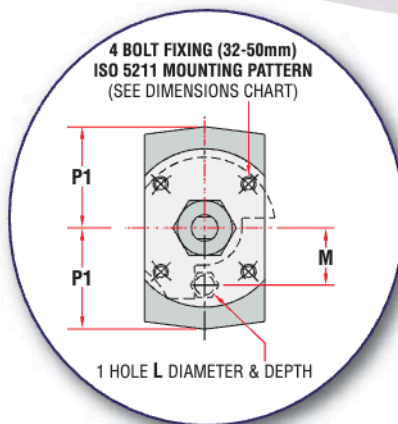

## Dimensions (mm)

NOTE: Main drawings show 15-25mm body. See inset drawing for 32-50mm. When wrench not fitted, flats on stem parallel to pipeline axis denotes ball open.

Valve Size	Port Ø Min.	A	B	C	D	E	STEM		J	K	L THREAD & DEPTH	M	P1	P2	Q	MOUNTING PLATFORM (ISO 5211)			WEIGHT (Kg)
							F A/F	G THREAD								ISO SIZE	MOUNTING HOLES	PLATFORM RECESS	
15	10.9	81.65 79.52	40.29	26.7 26.5	11.68 11.04	10.69 10.19	5.54 5.46	3/8"-24 UNF	57.9	136.0	M6 x1.0p 9.5 MIN	24.0	23.8	30.4	23.8				0.9
20	14.0	95.61 93.49	47.28	29.1 28.9	11.68 11.04	10.69 10.19	5.54 5.46	3/8"-24 UNF	60.3	136.0	M6 x1.0p 9.5 MIN	27.0	27.2	33.4	27.2				1.2
25	20.4	116.75 114.62	57.84	38.1 37.9	17.94 17.16	15.19 14.69	7.54 7.47	7/16"-20 UNF	64.8	149.0	M8 x1.25p 9.7 MIN	31.75	32.7	40.5	32.7				2.1
32	25.1	132.30 130.17	65.62	37.10 36.85	23.74 22.91	15.19 14.69	7.54 7.47	7/16"-20 UNF	69.6	149.0	M5 x0.8p 6.0 MIN	19.5	36.3		36.3	F04	4 OFF M5 x0.8p x7.5 DEEP MIN ON 42.0 P.C.D.	Ø 30.15 / 30.02 x4.29 / 3.52 DEEP	2.7
40	31.3	145.41 143.29	72.18	44.0 43.75	29.55 28.73	18.39 17.89	8.71 8.64	9/16"-18 UNF	77.9	254.0	M6 x1.0p 7.5 MIN	23.0	42.3		42.3	F05	4 OFF M6 x1.0p x8.7 DEEP MIN ON 50.0 P.C.D.	Ø 35.15 / 35.02 x4.01 / 3.26 DEEP ON 50.0 P.C.D.	4.3
50	37.7	165.34 163.21	82.14	48.75 48.50	29.55 28.73	18.39 17.89	8.71 8.64	9/16"-18 UNF	82.6	254.0	M6 x1.0p 8.7 MIN	23.0	47.4		47.4	F05	4 OFF M6 x1.0p x8.7 DEEP MIN ON 50.0 P.C.D.	Ø 35.15 / 35.02 x4.01 / 3.26 DEEP	5.7

## Pressure Temperature Ratings

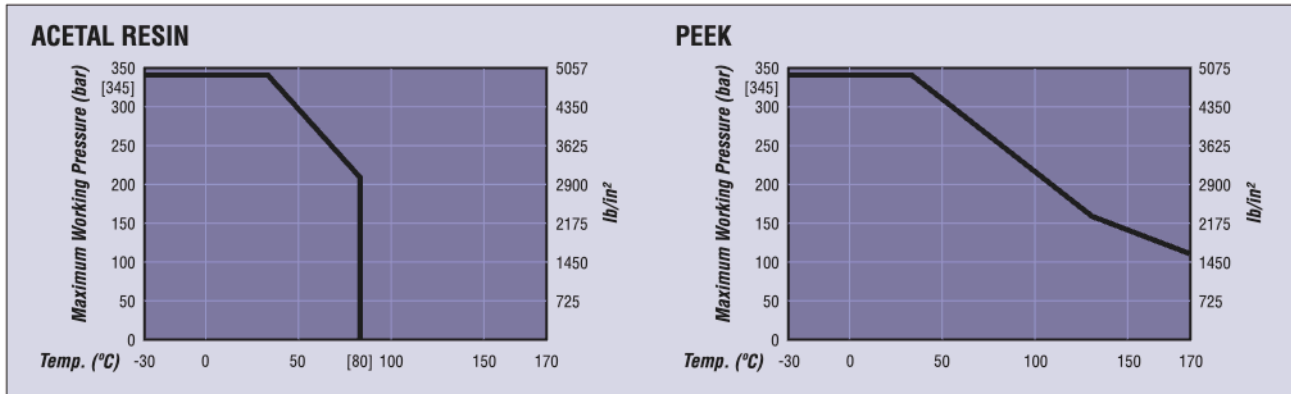

## Standards of Compliance

Screwed Valves	Body connector screwed female to the following thread specifications: NPT ANSI B1.20.1 (NPT) BSP Taper - BS EN 10226 BSP Parallel - ISO 228/1
Socket Weld Valves	Prepared for assembly to plain end pipe in accordance with BS 1600 API 5L BS 3600
Butt Weld Valves	Prepared in accordance with ASME Code Section IX, and to the following specifications : - API 5L BS 1600 Schedules 160/80
Pressure Test Specification	BS EN 12266 : Part 1
Quality Assurance	BS EN ISO 9001 : 2000

## Flow Coefficients

Valve Size		Flow Coefficients		Equivalent Length of Pipe	
mm	in	Cv	Kv	Feet	Metres
8 - 15	¼ - ½	8.0	6.9	1.9	0.58
20	¾	12.0	10.4	5.5	1.67
25	1	32.0	28.1	3.0	0.91
32	1¼	48.0	41.4	4.6	1.4
40	1½	80.0	69.2	3.9	1.19
50	2	104.0	90.0	9.0	2.28

Cv – Flow in US GPM Pressure – psi  
Kv – Flow in M<sup>3</sup>/hr Pressure – bar



5HP44 with Norbro Series 40R pneumatic actuator.



5HP44 with Norbro Series 75 electric actuator.

### How to order Worcester Valves and other Worcester products

Please order Worcester Valves and other products by description, not by part number. We need a precise description of the valve you require. We will then translate this information into our own coding for order processing and production. Please state the despatch address and desired date of delivery.

Installation, Operating and Maintenance Instructions are available on request.

FCD WCEBR0006-02 Printed in Germany.

Due to continuous development of our product range, we reserve the right to alter the dimensions and information contained in this leaflet as required. Information given in this leaflet is made in good faith and based upon specific testing but does not, however, constitute a guarantee.



**Flowserve Flow Control (UK) Ltd.**  
Worcester Controls  
Burrell Road, Haywards Heath  
West Sussex RH16 1TL  
United Kingdom  
Telephone: +44 (0)1444 314400  
Telefax: +44 (0)1444 314401  
Email: wvukinfo@flowserve.com