

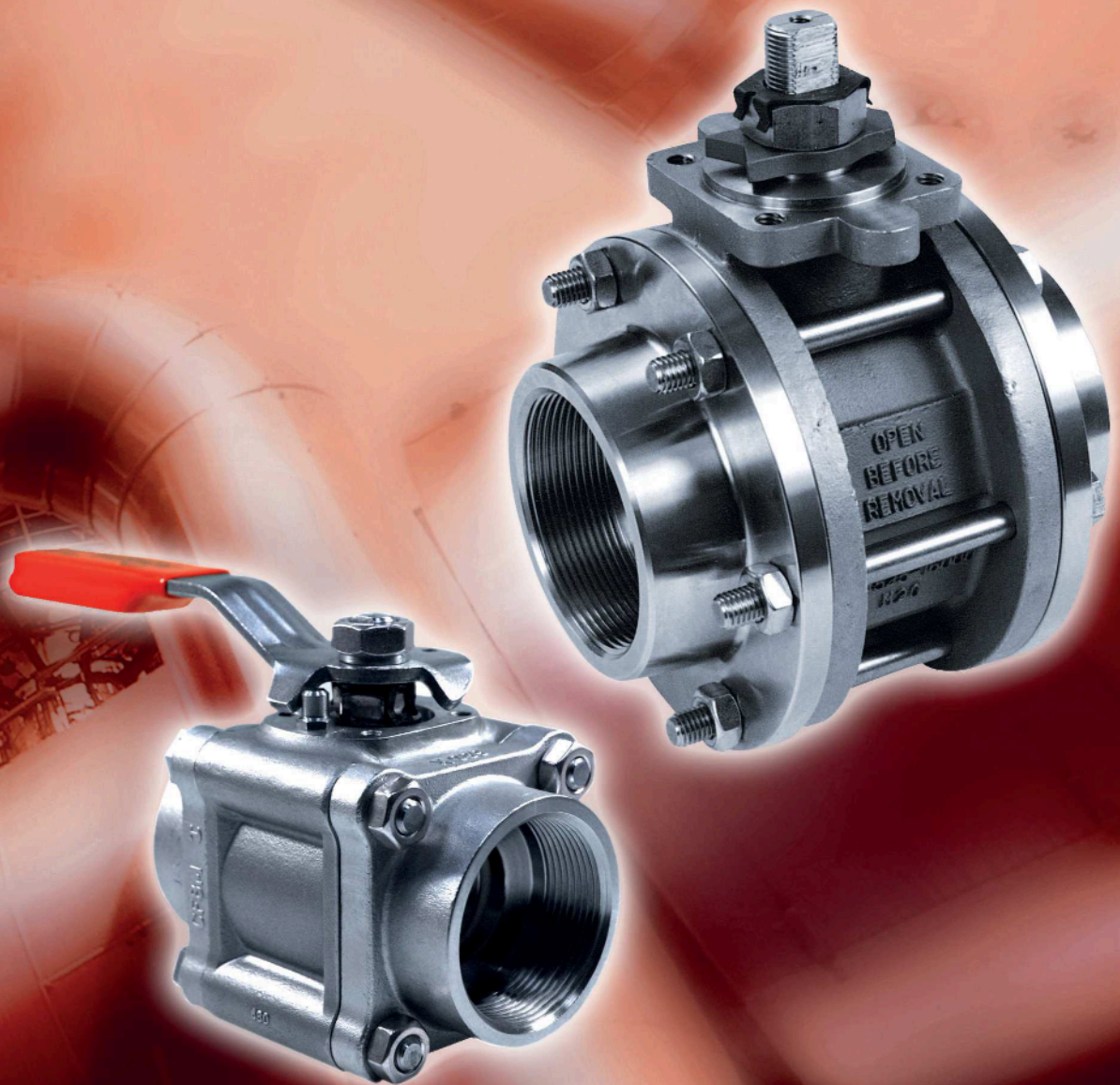

Worcester Controls Standard 3-Piece Ball Valves



Experience In Motion



The Flowserve Worcester Controls three-piece ball valve delivers rugged, high performance reliability for a range of applications, all in an easy-to-maintain design.

A variety of pipe ends, including socket weld, screwed or butt weld ends enables these valves to be adapted to fit both standard and more unusual piping specifications while the range of seat materials handles steam, chemicals, cryogenic gases, petroleum products, caustics, abrasive materials or fluids containing solids.

As you would expect, Worcester has developed and improved the Series 44/459 over the years to maintain its position as the 8-150mm valve design which others strive to equal. The 59 and 599 series full bore versions complete the range of 3-piece valves.

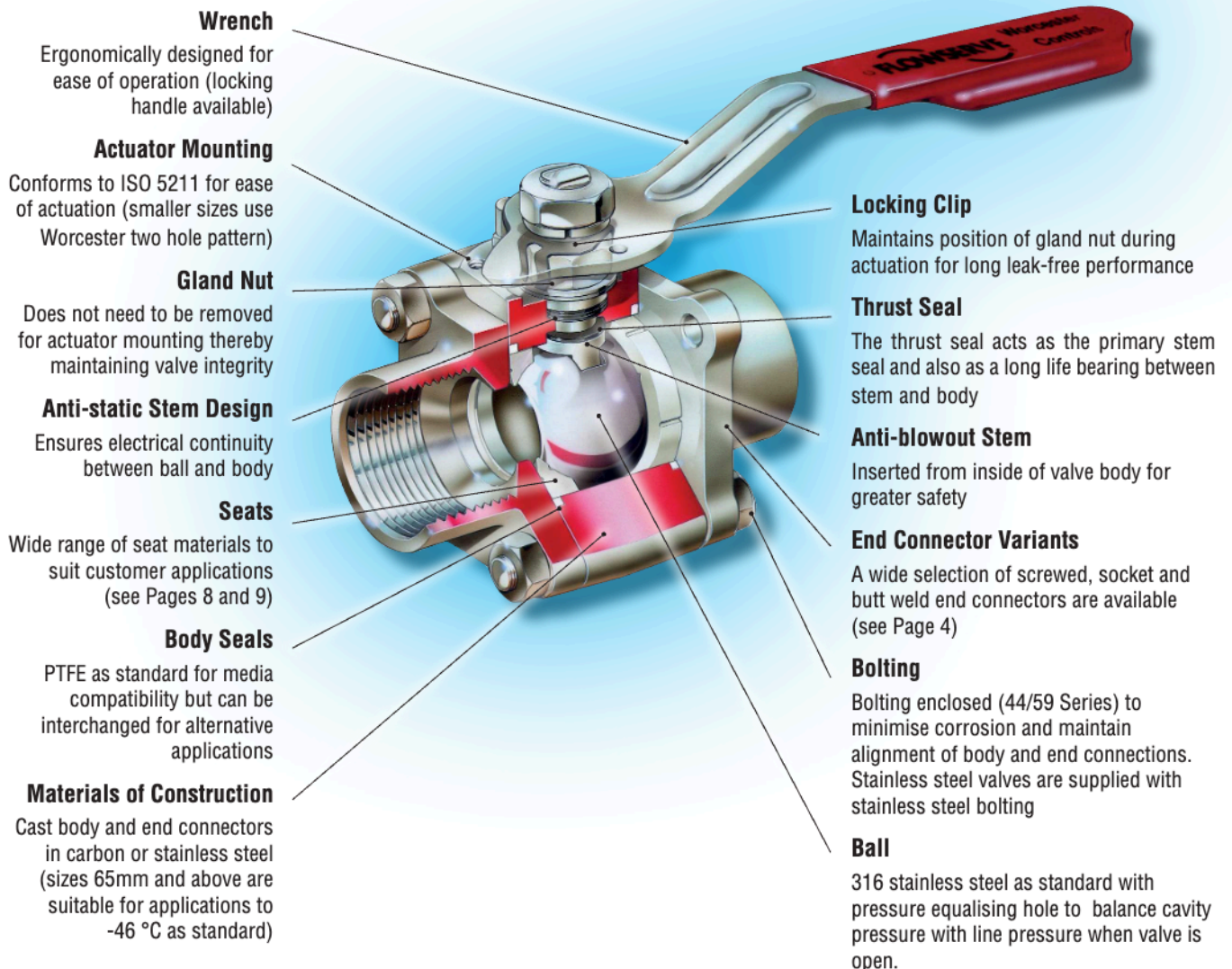

Standards of Compliance

Worchester have always taken the lead when it comes to standards of compliance and the 3-piece valve is no exception, meeting all the mandatory requirements along with a number of others relating to product for use in the process industry.

PED 2014/68/EU

The Pressure Equipment Directive was introduced to ensure the safety and integrity of pressure containing equipment used within Europe. The Directive requires design files including calculations to ASME BPVC Sect. VIII, risk assessments, Product testing, Pressure containing components with 3.1 Certification along with supporting QA certification validated by a Notified Body. CE marking for PED only applies to valves greater than DN25 nominal bore. Below that design files are still maintained but classified as SEP.

Atex 94/9/EC

The Atex Directive was established to prevent explosive atmospheres forming, prevent ignition and control the effect of explosions. Valves complying with the Atex requirement are CE marked with the standard designation. Worchester valves carry a rating Ex II2GDcX due to the anti-static devices used in the build.

FLOWSERVE WORCESTER (UK)	
20 A44-6666TT	T
DN50	
69 BAR -30°C	0 BAR -230°C
BALL 316	SEAT PTFE
CE 2014/68/EU 0086 2014/34/EU	9000012345/1000 Ex II2GDcX 2016

SIL (Safety Integrity Level) IEC61508

Safety Integrity is now an essential part of many process plants allowing assessments to be made based on the reliability of the equipment used within it. Worchester valves have been independently reviewed and assessed and given the rating of SIL 'SC 3'. This allows an assembly utilising a Worchester valve to carry a maximum overall rating of SIL 3 or less if other equipment has a lower rating

Fugitive Emission ISO15848

Introduced to ensure that product used in process plants can maintain a specified level of integrity based on service conditions. The Worchester 44 Series now has a combined class rating as follows;

Tightness Class: BH (Helium)
 Endurance Class: C01 (500 cycles)
 Test Pressure: 69 Bar
 Test temperature: Ambient 20 °C & 120 °C
 Stem seal Adjustments (SSA): 0 (No adjustments)
 ISO FE BH-C01-SSA 0-t(-29 °C to 120 °C)-69 bar

End Connector Variants

Worchester offers a wide range of end connector variants to meet international, European and regional standards. The variety of connectors is shown below with their reference standard against the Worchester 3-digit product code designation.

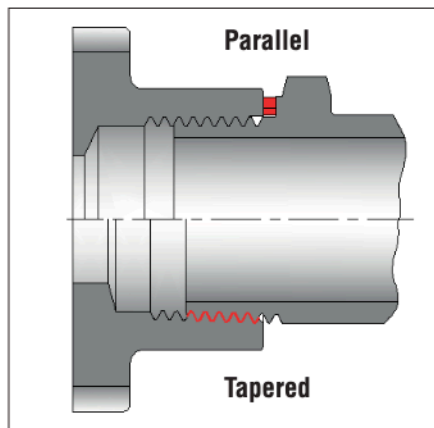

Threaded

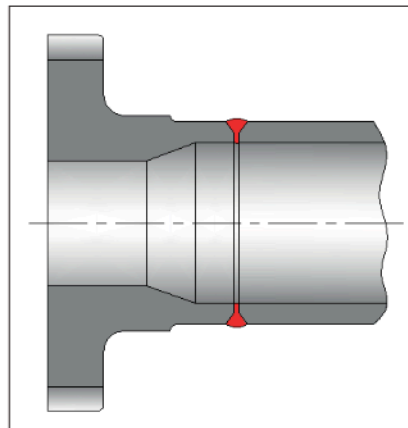

Butt Weld

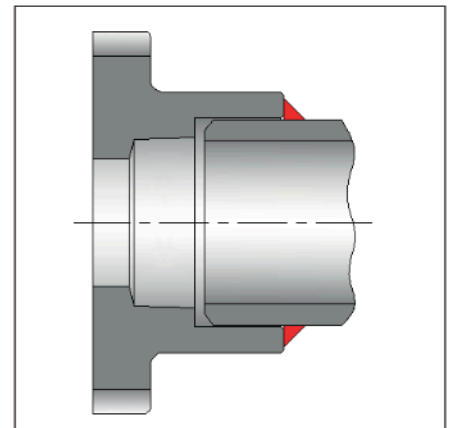

Socket Weld

Type	Code	Reference	Standard of Compliance
Threaded	SEP	BSPP / G	BS EN ISO 228-1
	SET	BSPT / Rc	BS EN ISO 10226-1 / ISO 7-1
	SEN	NPT	ASME B1.20.1
Butt Weld	BW5	Schedule 5	Pipe to BS1600, ASME B36.10/B36.19 Butt weld preparation to ASME B16.25
	BWE	Schedule 10	
	BWA	Schedule 40	
	BWC	Schedule 80	
	BW6	Schedule 160	
	BOD	Hygienic Tube	Inch series O/D pipe, 16 swg wall
	BWG	ISO Pipe (special)	ISO 4200 Series 1 O/D with Wall thickness to EN 1092-1 PN16/40
	BWJ	ISO Pipe (special)	ISO 4200 Series 1 O/D with 2.6mm Wall thickness
	BWH	ISO Pipe (special)	ISO 4200 Series 1 O/D with I/D as per valve DN size
	BWK	DIN Pipe	DIN 2463 Row 1
	BWL	DIN Pipe	DIN 11850 Row 2
	BWM	Swedish Std	SSG7837 (Pulp and Paper)
	BWR	DIN Pipe	DIN 11850 Row 1
BX*	ISO Pipe	ISO 4200 Series 1	
BY*	ISO Pipe	ISO 4200 Series 2	
BZ*	ISO Pipe	ISO 4200 Series 3	
Socket Weld	SWA	Schedule 40	Pipe to BS1600, ASME B36.10/B36.19
	SWC	Schedule 80	Pipe to BS1600, ASME B36.10/B36.19 (Not available on A44)

Alternative end connectors such as extended or Tri-clamp are available upon request.

Application Variants



EC 1935 Food Contact Valve

This special variation of the 44/459 series fully complies with the requirements of Regulation EC 1935, enabling it to be safely installed on applications involving direct food contact.



Cryogenic Valves C44/59/459/599

The cryogenic valve is suitable for low temperature applications, including CO₂, N₂, Ar, O₂, LNG and other liquid gases. It is available in stainless steel or brass.

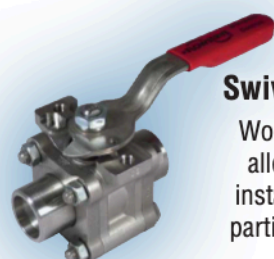

Swivel Ended Valves AS44/59

Worcesters swivel-end connector allows for simple orientation and installation of butt welded valves, particularly when long, complicated sections of pre-fabricated pipework are used.



High Integrity Valve E44

The unique dual stem sealing design of the Worcesters Enviro-Safe valve makes it ideal for toxic media and high cycling applications.



Clean Valves WK70

This valve has been specifically developed for use in semi-conductor, pharmaceutical and bio-tech applications.



Control Valves V44/459

Worcesters versatile rotary V-Flow control valve offers accurate control through a range of V-ported, characterized seats, providing a compact control valve for a variety of applications (Also available in firesafe version).



High Pressure Valves 5HP44

The 5HP44 is Worcesters three-piece ball valve for high pressure hydraulic systems up to 345 Bar (5000 psi).



Steam and Thermal Fluid Valves AW44/59

Specifically designed for on/off steam applications in conditions up to 250 psi (continuous saturated steam) or 1500 psi (thermal fluids), the AW44 is available in stainless or carbon steel.



Firesafe Valves F44/59/459/599

This firesafe design is particularly suitable for hazardous areas in hydrocarbon and chemical process lines.



Diverter Valves 13/14

Worcesters Series 13/14 range of three-way valves has been designed for diverting and mixing process media, and features a number of variants which provide a range of operational solutions. Available in bottom entry and side entry configurations

Construction A44/A59

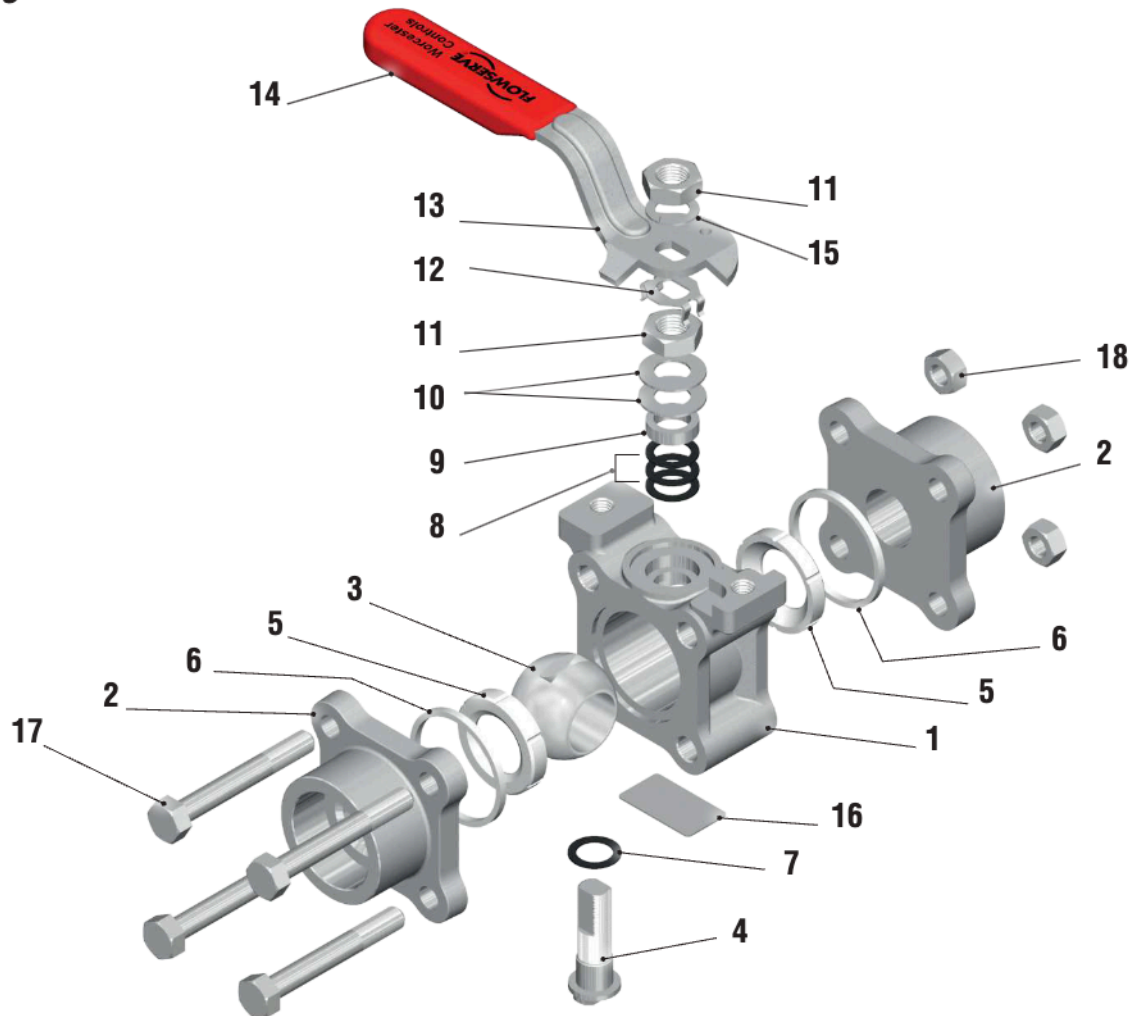

Item	Description	Carbon Steel	Stainless Steel	Item	Description	Carbon Steel	Stainless Steel
1	Body	ASTM A216 WCB UNS J03002	ASTM A351 CF8M UNS J92900	11	Gland/Wrench Nut*		Stainless Steel
2	End Connector	ASTM A216 WCB UNS J03002	ASTM A351 CF3M UNS J92800	12	Locking Clip*		Stainless Steel
3	Ball	ASTM A479 316 UNS S31600 ASTM A351 CF8M UNS J92900		13	Wrench	Carbon Steel	Stainless Steel
4	Stem	Stainless Steel AISI Type 316		14	Wrench Sleeve		Vinyl Plastisol
5	Seats*	T PTFE, Virgin R PTFE, 15% Glass Filled H PTFE, 25% Glass Filled P Fluorofill (10% Glass, 15% Carbon Filled) Also Acetal, PEEK, UHMWPE & Metal Seats		15	Spring Washer		Stainless Steel
6	Body Seal*	PTFE, Virgin		16	Identification Plate		Stainless Steel
7	Stem Thrust Seal*	PTFE, 35% Carbon Filled		17	Body Bolts	BS3692 Gr.8.8 ASTM A193M Gr.B7	BS EN 3506-1 A4-80 BS6105 Gr.A4-80 BS1506 Gr.MB8MX ASTM A193M Gr.B8M Cl.2
8	Gland Packing*	PTFE, 35% Carbon Filled		18	Body Nuts	BS3692 Gr.8 ASTM A194M Gr.2H	BS EN 3506-2 A4-80 BS6105 Gr.A4-80 BS1506 Gr.M8MX ASTM A194M Gr.8M
9	Gland Follower	Stainless Steel					
10	Disc Springs*	Stainless Steel					

1 Items marked with * denote components supplied in repair kits.

2 All material grades stated are known to be correct at the time of issue but may be subject to change. Customers are advised to contact Flowserve when exact materials of construction are required.

3 Stainless steel stop pin fitted on 1¼" - 2" A44 and 1" - 1½" A59

Construction A459/A599

Wrench kit supplied separately. To be ordered at time of valve Purchase Order.

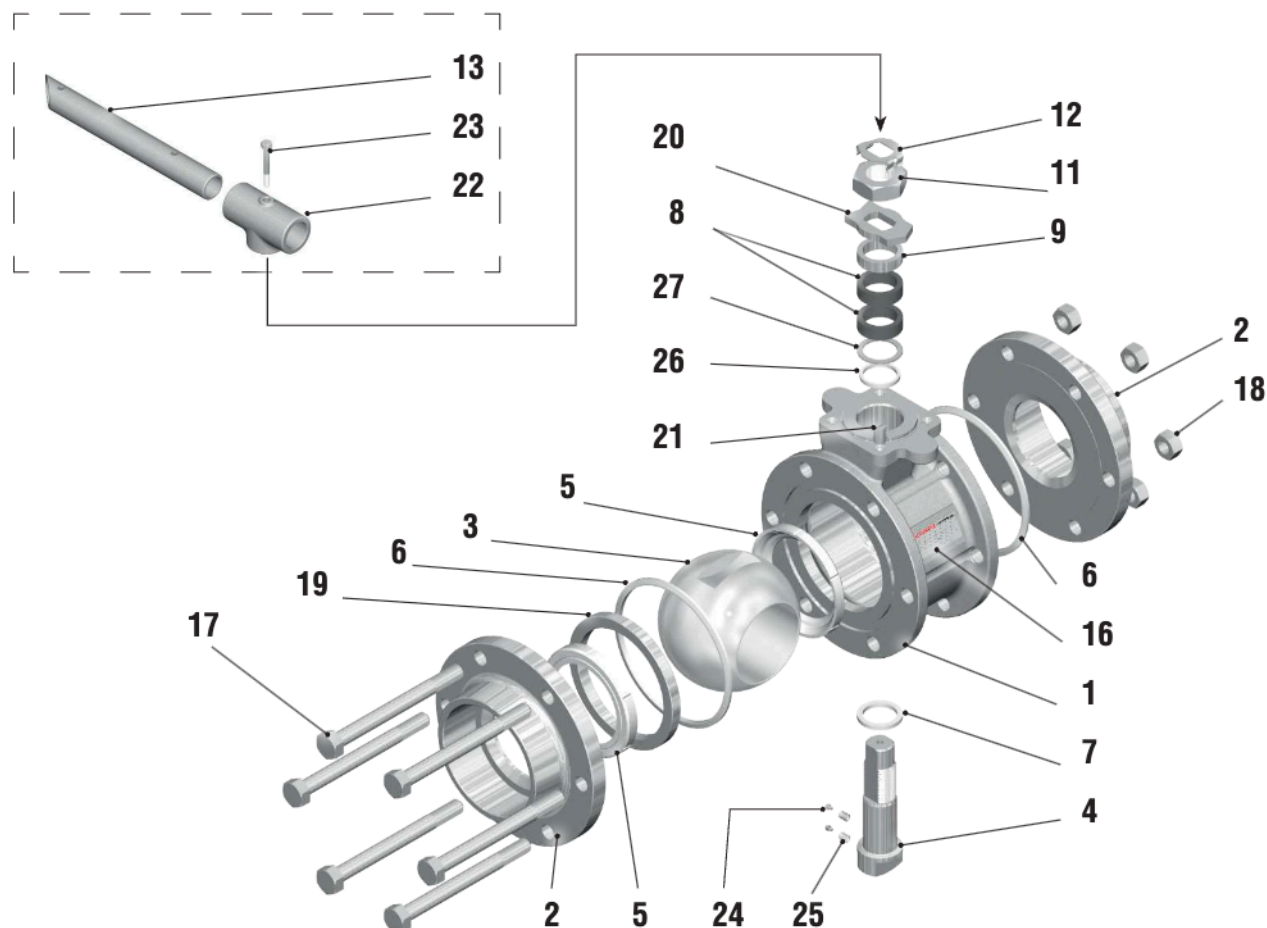

Item	Description	Carbon Steel	Stainless Steel	Item	Description	Carbon Steel	Stainless Steel
1	Body	ASTM A352 LCB UNS J03003	ASTM A351 CF8M UNS J92900	16	Identification Plate	Stainless Steel	
2	End Connector	ASTM A352 LCB UNS J03003	ASTM A351 CF3M UNS J92800	17	Body Bolts	ASTM A193M Gr.B7 BS3692 Gr.8.8	ASTM A193M Gr.B8M Cl.2 BS EN 3506-1 A4-80 BS1506 Gr.MB8MX
3	Ball	Stainless Steel ASTM A351 CF8M UNS J92900		18	Body Nuts	ASTM A194M Gr.2H	ASTM A194M Gr.8M
4	Stem	Stainless Steel AISI Type 316		19	Seat Ring Retainer	BS3692 Gr.8 ASTM A352 LCB UNS J03003	BS EN ISO 3506-2 Gr.A4-80 BS1506 Gr.M8MX ASTM A351 CF8M UNS J92900
5	Seats*	T PTFE, Virgin R PTFE, 15% Glass Filled H PTFE, 25% Glass Filled P Fluorofill (10% Glass, 15% Carbon Filled) Also Acetal, PEEK, UHMWPE & Metal Seats		20	Stop Indicator	Carbon Steel	Stainless Steel
6	Body Seal*	PTFE, Virgin		21	Stop Pin	Carbon Steel	Stainless Steel
7	Stem Thrust Seal*	PTFE, 25% Glass Filled		22	Wrench Head	Cast Iron / Stainless Steel	
8	Gland Packing*	Graphite		23	Wrench Bolt	Stainless Steel	
9	Gland Follower	Stainless Steel		24	Anti-static Plunger	Stainless Steel	
11	Gland/Wrench Nut*	Carbon Steel	Stainless Steel	25	Anti-static Spring	Stainless Steel	
12	Locking Clip*	Stainless Steel		26	Stem Location Ring	Stainless Steel	
13	Wrench	Carbon Steel		27	Stem Seal (Secondary)	PTFE, Virgin	

1 Items marked with * denote components supplied in repair kits.

2 Material selection may alter the valves operating pressure/temperature range. Customers are advised to contact Flowserve on ratings for special valve builds.

3 All material grades stated are known to be correct at the time of issue but may be subject to change. Customers are advised to contact Flowserve when exact materials of construction are required.

Pressure Temperature Ratings

PTFE based seats

VIRGIN PTFE (T)

Virgin PTFE is the most common sealing material and is suitable for almost all media as it has excellent chemical resistance.

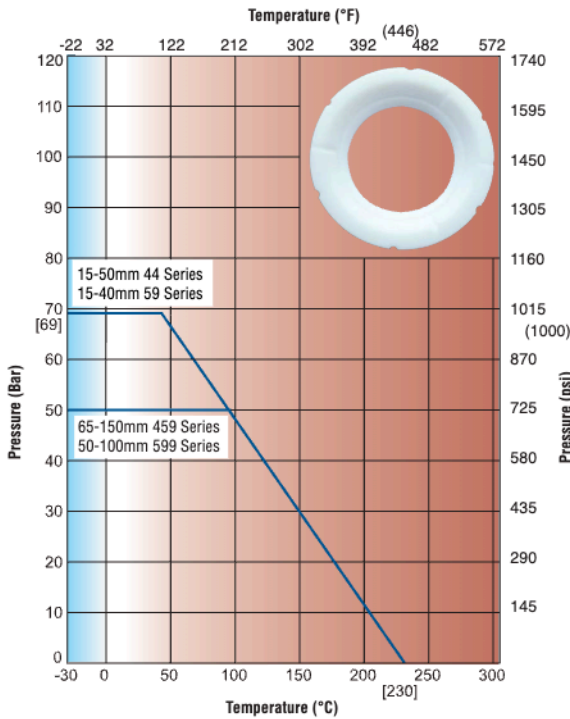

15% GLASS FILLED PTFE (R)

Glass re-inforced PTFE seats are stronger than virgin and have higher pressure/temperature ratings. Chemical resistance as per virgin PTFE.

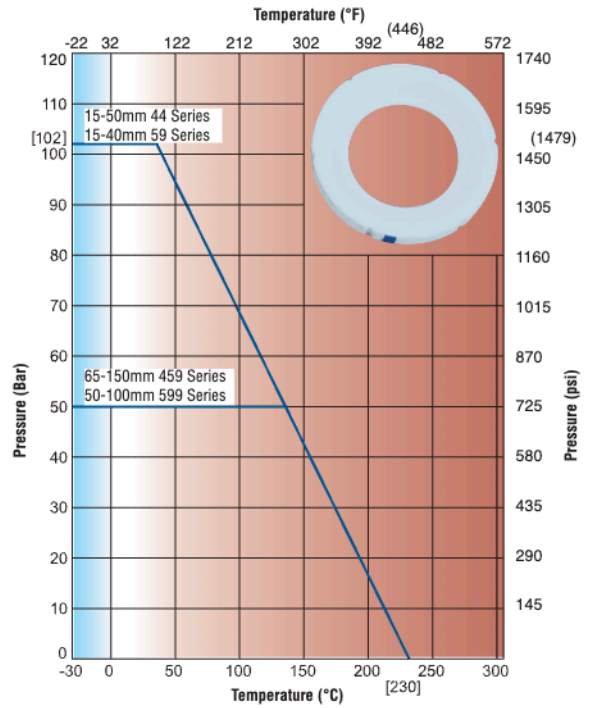

25% GLASS FILLED PTFE (H)

Glass re-inforced PTFE material offering a greater pressure / temperature capability than the R seat.

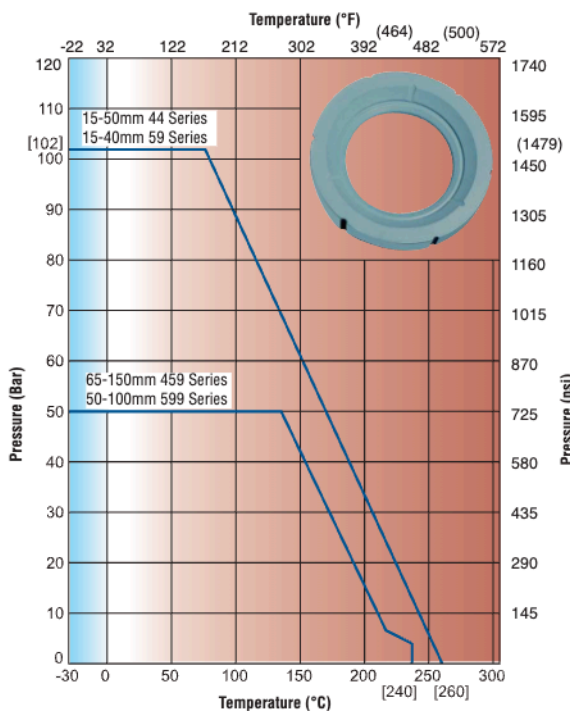

FLUOROFILL (P)

Carbon, glass and graphite filled PTFE material, an excellent seat material for steam and thermal services. Due to its high cycling capabilities, it is the recommended soft seat for modulating control applications.

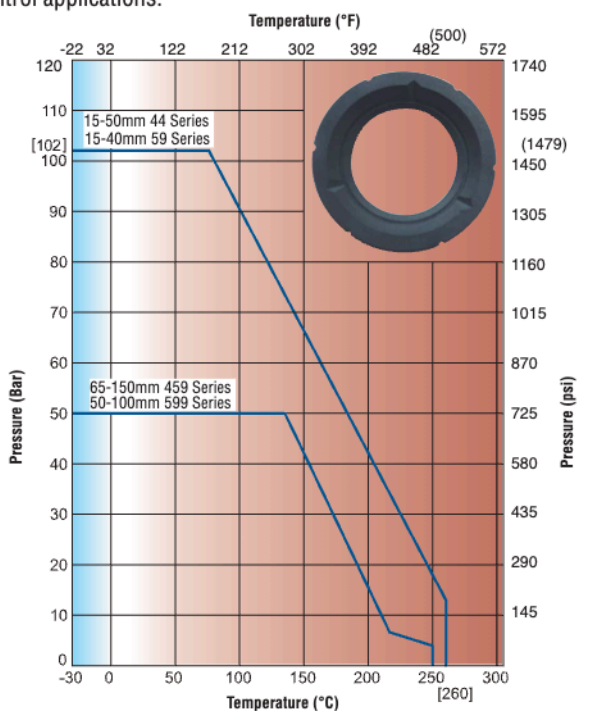

Pressure Temperature Ratings

Non PTFE seats

UHMWPE (U)

Ultra High Molecular Weight Polyethylene offers good performance characteristics in applications where PTFE is not suitable (for example on tobacco duty). It also has good abrasion resistance.

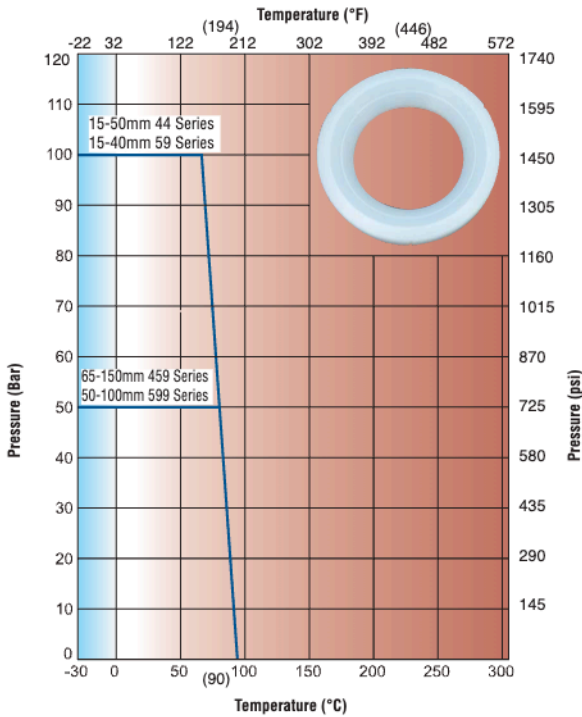

ACETAL (Y)

Machined from acetal homopolymer, these seats are capable of handling extremely high pressures.

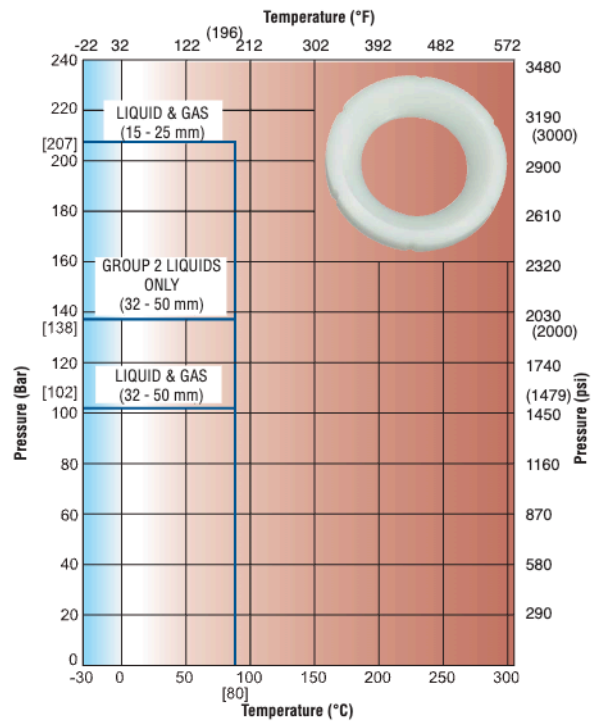

PEEK (A - DN15-25) (X - DN32-150)

PEEK is Poly Ether Ether Ketone, a material which demonstrates outstanding pressure capabilities at elevated temperatures. PEEK has excellent chemical and abrasion resistance.

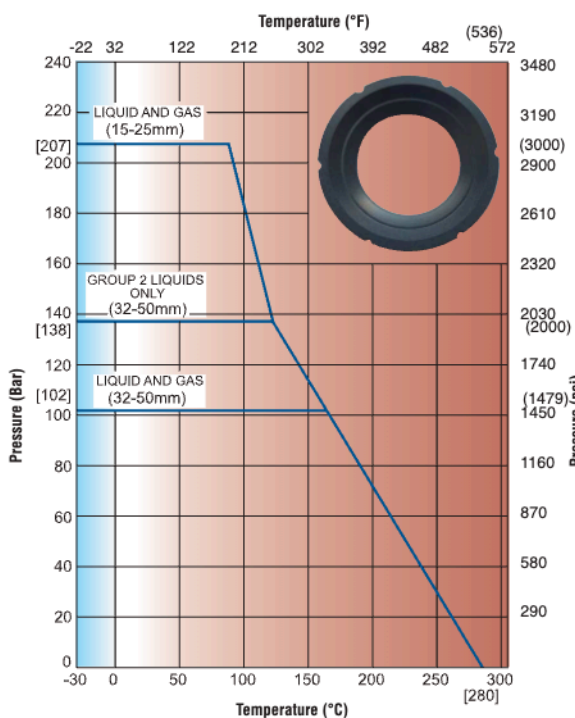

METAL – ALPHA (N) / GAMMA (G)

A 316L sintered metal seat impregnated with PTFE - Alpha (N) or graphite - Gamma (G) improves the strength and abrasion resistance of metal.

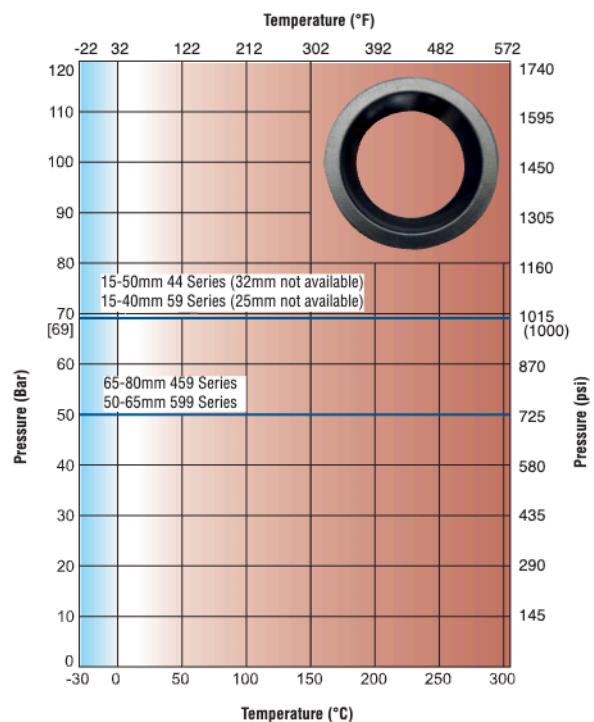

Dimensions (mm)

A44 8-50 mm Reduced Bore

TO CLOSE
90° CLOCKWISE

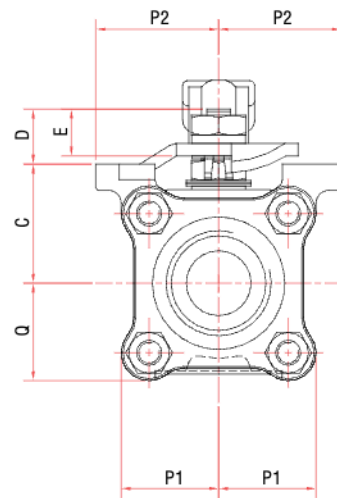
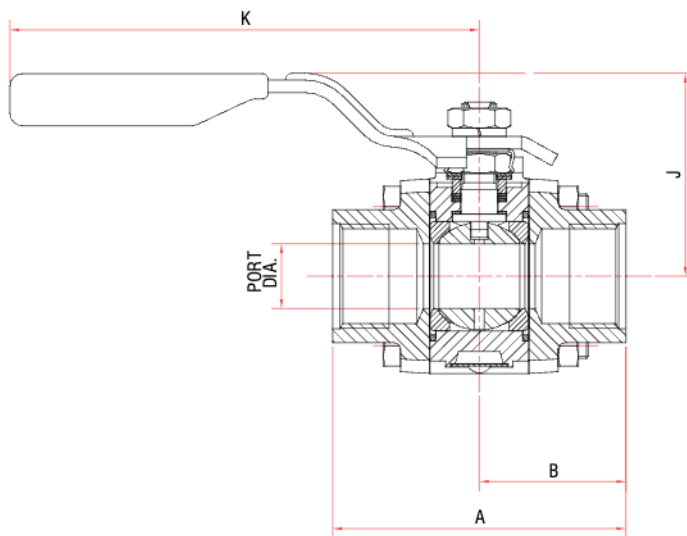
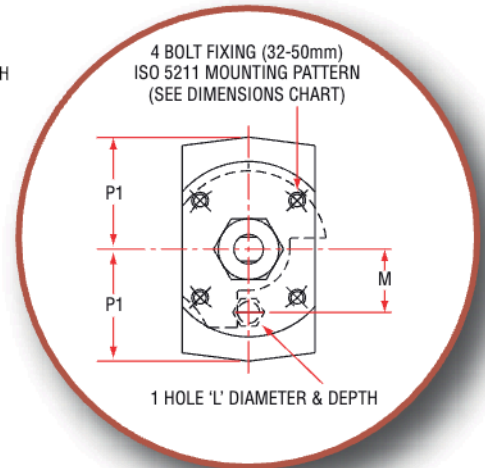
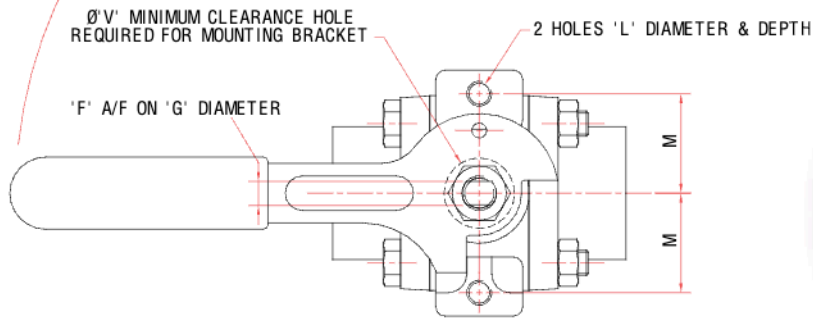

Valve Size (mm)	Port Ø Min	A	B	C	D	E	Stem		J	K	L Thread & Depth	M	P1	P2	Q	V Ø	Mounting Platform (ISO 5211)			Weight Kg
							F A/F	G Ø Thread									ISO Size	Mounting Holes	Platform Recess	
15	10.9	66.25 64.52	32.69	26.7 26.5	11.68 11.04	10.69 10.19	5.54 5.46	3/8"-24 UNF	57.9	136.0	M6 x1.0p 9.5 Min	24.0	23.8	30.4	23.8	19.5				0.7
20	14.0	71.81 70.09	35.48	29.1 28.9	11.68 11.04	10.69 10.19	5.54 5.46	3/8"-24 UNF	60.3	136.0	M6 x1.0p 9.5 Min	27.0	27.2	33.4	27.2	19.5				0.9
25	20.4	94.55 92.82	46.84	38.1 37.9	17.94 17.16	15.19 14.69	7.54 7.47	7/16"-20 UNF	64.8	149.0	M8 x1.25p 9.7 Min	31.75	32.7	40.5	32.7	22.5				1.6
32	25.1	106.90 105.17	53.02	37.10 36.85	23.74 22.91	15.19 14.69	7.54 7.47	7/16"-20 UNF	69.6	149.0	M5 x0.8p 6.0 Min	19.5	36.3		36.3	22.5	F04	4 OFF M5 x0.8p x7.5 Deep Min ON 42.0 P.C.D.	Ø 30.15/30.02 x4.29/3.52 Deep	2.2
40	31.3	115.41 113.6	57.28	44.0 43.75	29.55 28.73	18.39 17.89	8.71 8.64	9/16"-18 UNF	77.9	181.0	M6 x1.0p 7.5 Min	23.0	42.3		42.3	29.5	F05	4 OFF M6 x1.0p x8.7 Deep Min ON 50.0 P.C.D.	Ø 35.15/35.02 x4.01/3.26 Deep	3.2
50	37.7	127.94 126.21	63.54	48.75 48.50	29.55 28.73	18.39 17.89	8.71 8.64	9/16"-18 UNF	82.6	181.0	M6 x1.0p 8.7 Min	23.0	47.4		47.4	29.5	F05	4 OFF M6 x1.0p x8.7 Deep Min ON 50.0 P.C.D.	Ø 35.15/35.02 x4.01/3.26 Deep	4.3

Dimensions (mm)

A459 65-150 mm Reduced Bore

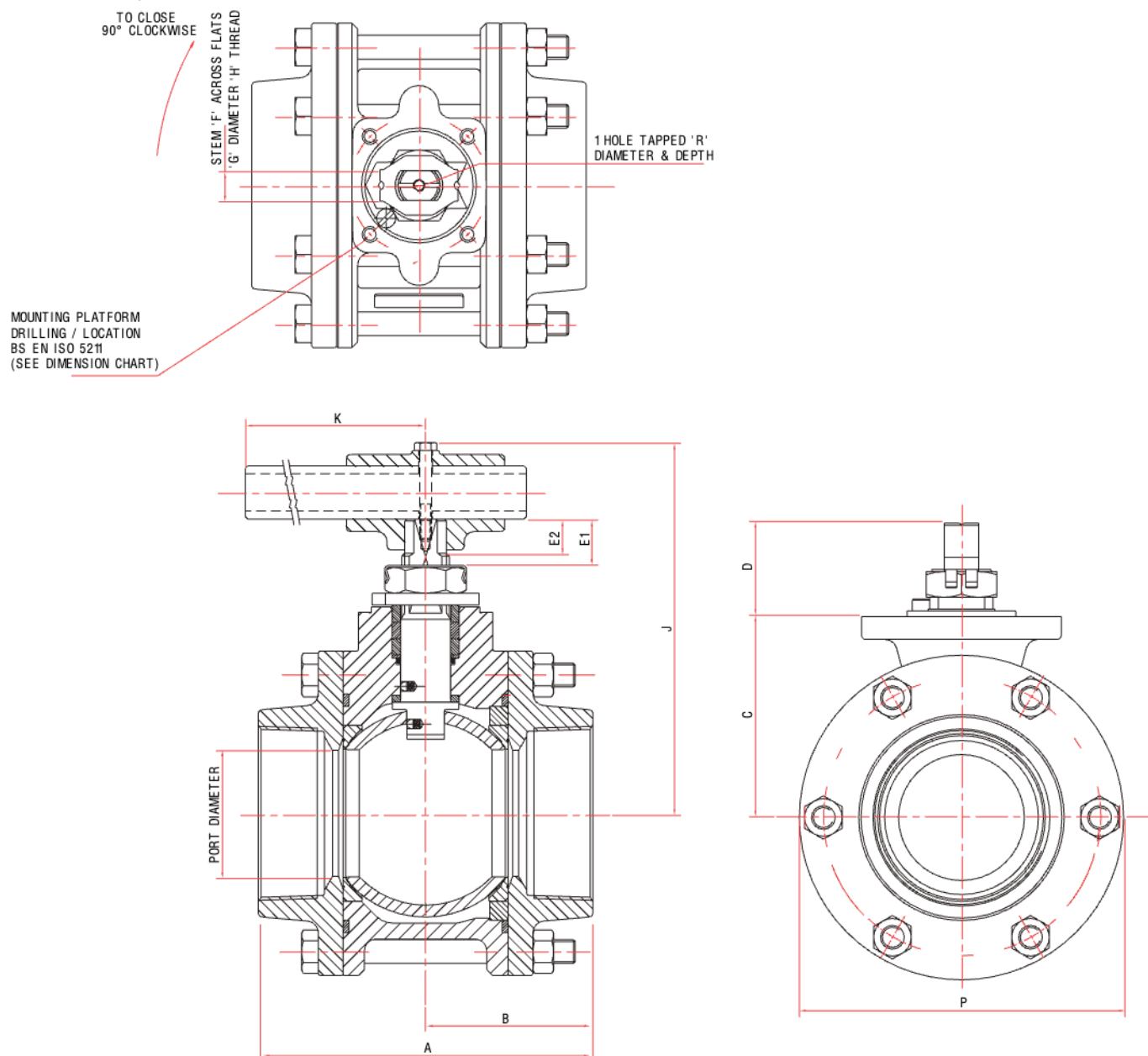

Valve Size (mm)	Port Ø Min	A	B	C	D	E1 Min	E2 Min	F A/F	Stem GØ	H Thread	J	K	P Ø	R Thread & Depth	Mounting Platform (ISO 5211)			Weight Kg
															ISO Size	Mounting Holes	Platform Recess	
65	50.8	149.74 148.11	74.46	87.57 86.87	43.83 41.50	13.15	-	14.0 13.9	-	M20 x1.5p	156.1	225.0	148.0	M6 x1.0p 10.0 MIN	F07	4 OFF M8 x1.25p ON 70.0 P.C.D.	Ø 54.97/54.90 x3.0/2.6 HIGH	9.0
80	63.55	170.04 168.31	84.59	101.90 101.10	51.10 48.44	19.37	16.80	15.1 15.0	21.2 21.0	M24 x2.0p	190.0	350.0	168.0	M6 x1.0p 12.0 MIN	F07	4 OFF M8 x1.25p ON 70.0 P.C.D.	Ø 54.97/54.90 x3.0/2.6 HIGH	13.3
100	76.2	214.67 212.94	106.9	119.90 119.10	55.70 53.04	21.67	21.00	19.3 19.2	27.2 27.0	M30 x2.0p	213.5	557.0	196.0	M6 x1.0p 12.0 MIN	F10	4 OFF M10 x1.5p ON 102.0 P.C.D.	Ø 69.97/69.85 x3.0/2.6 HIGH	23.0
150	102.0	299.26 297.54	149.20	147.10 146.30	73.05 70.39	30.27	28.20	26.6 26.5	33.2 33.0	M36 x2.0p	274.8	850.0	256.0	M8 x1.25p 12.0 MIN	F12	4 OFF M12 x1.75p ON 125.0 P.C.D.	Ø 84.97/84.85 x3.0/2.6 HIGH	51.0

Dimensions (mm)

A59 8-40 mm Full Bore

TO CLOSE
90° CLOCKWISE

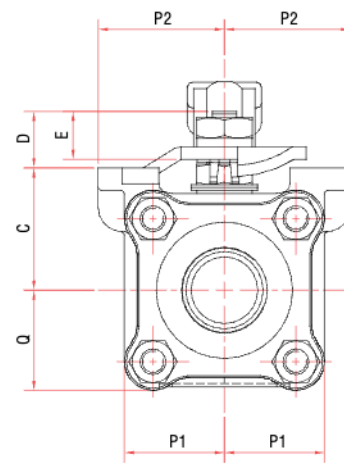
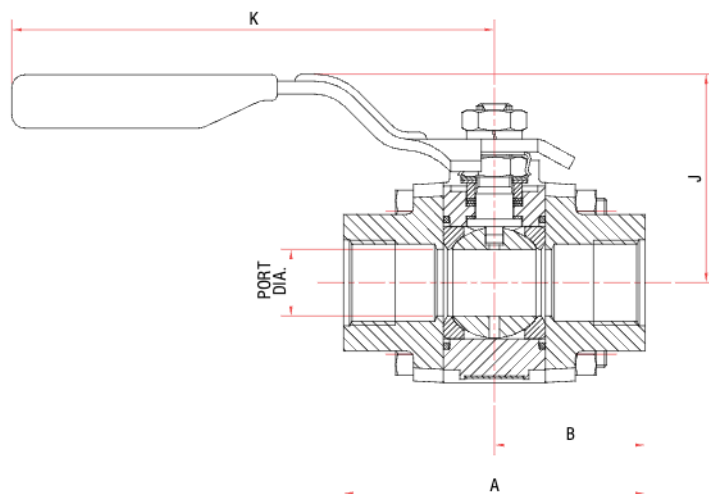
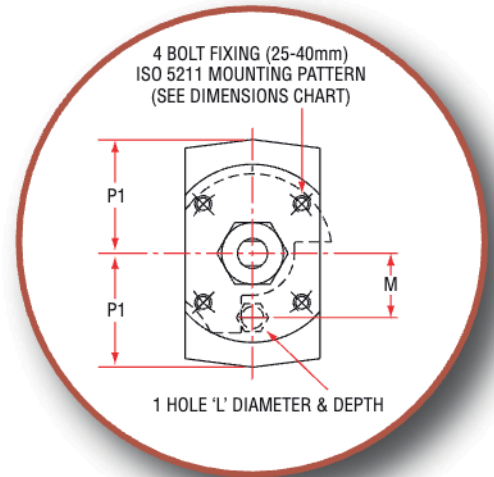
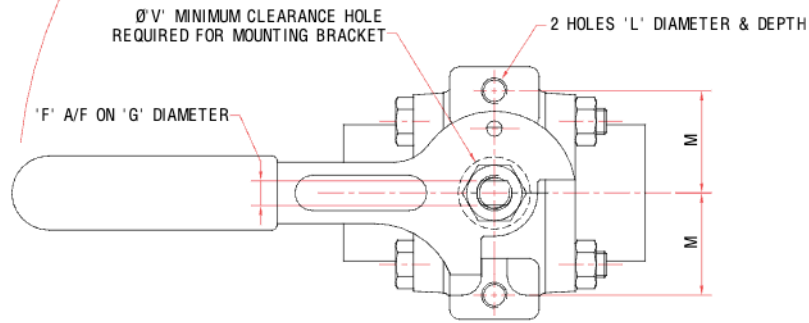

Valve Size (mm)	Port Ø Min	A	B	C	D	E	Stem		J	K	L Thread & Depth	M	P1	P2	Q	V Ø	Mounting Platform (ISO 5211)			Weight Kg
							F A/F	G Ø Thread									ISO Size	Mounting Holes	Platform Recess	
8-15	14.0	71.81 70.09	35.48	29.1 28.9	11.68 11.04	10.69 10.19	5.54 5.46	3/8"-24 UNF	60.3	136.0	M6 x1.0p 9.5 MIN	27.0	27.2	33.4	27.2	19.5				0.9
20	20.4	94.55 92.82	46.84	38.1 37.9	17.94 17.16	15.19 14.69	7.54 7.47	7/16"-20 UNF	64.8	149.0	M8 x1.25p 9.7 MIN	31.75	32.7	40.5	32.7	22.5				1.6
25	25.1	106.90 105.17	53.02	37.10 36.85	23.74 22.91	15.19 14.69	7.54 7.47	7/16"-20 UNF	69.6	149.0	M5 x0.8p 6.0 MIN	19.5	36.3		36.3	22.5	F04	4 OFF M5 x0.8p x7.5 DEEP MIN ON 42.0 P.C.D.	Ø 30.15/30.02 x4.29/3.52 DEEP	2.2
32	31.3	115.41 113.69	57.28	44.0 43.75	29.55 28.73	18.39 17.89	8.71 8.64	9/16"-18 UNF	77.9	181.0	M6 x1.0p 7.5 MIN	23.0	42.3		42.3	29.5	F05	4 OFF M6 x1.0p x8.7 DEEP MIN ON 50.0 P.C.D.	Ø 35.15/35.02 x4.0/3.26 DEEP	3.2
40	37.7	127.94 126.21	63.54	48.75 48.50	29.55 28.73	18.39 17.89	8.71 8.64	9/16"-18 UNF	82.6	181.0	M6 x1.0p 8.7 MIN	23.0	47.4		47.4	29.5	F05	4 OFF M6 x1.0p x8.7 DEEP MIN ON 50.0 P.C.D.	Ø 35.15/35.02 x4.0/3.26 DEEP	4.3

Dimensions (mm)

A599 50-100 mm Full Bore

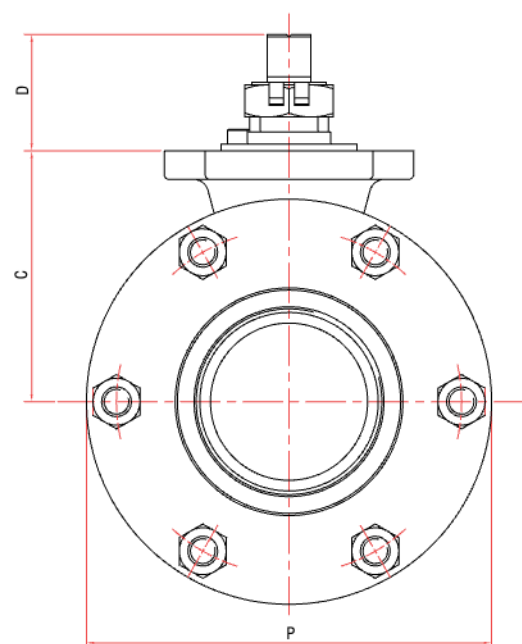
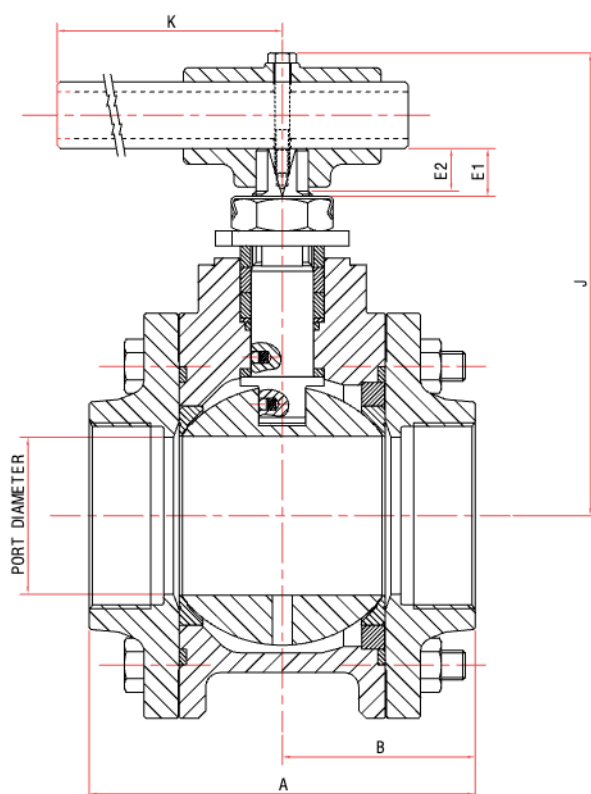
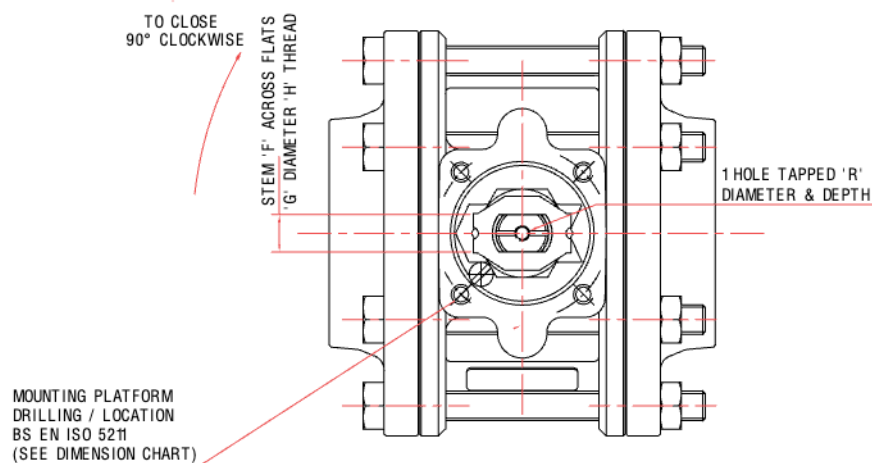

Valve Size (mm)	Port Ø Min	A	B	C	D	E1 Min	E2 Min	F A/F	Stem G Ø	H Thread	J	K	P Ø	R Thread & Depth	Mounting Platform (ISO 5211)			Weight Kg
															ISO Size	Mounting Holes	Platform Recess	
50	50.8	149.74 148.11	74.46	87.57 86.87	43.83 41.50	13.15	-	14.0 13.9	-	M20 x1.5p	156.1	225.0	148.0	M6 x1.0p 10.0 MIN	F07	4 OFF M8 x1.25p ON 70.0 P.C.D.	Ø 54.97/54.90 x3.0/2.6 HIGH	9.0
65	63.55	157.24 155.51	78.19	101.90 101.10	51.10 48.44	19.37	16.80	15.1 15.0	21.2 21.0	M24 x2.0p	190.0	350.0	168.0	M6 x1.0p 12.0 MIN	F07	4 OFF M8 x1.25p ON 70.0 P.C.D.	Ø 54.97/54.90 x3.0/2.6 HIGH	13.3
80	76.2	192.27 190.77	95.75	119.90 119.10	55.70 53.04	21.67	21.00	19.3 19.2	27.2 27.0	M30 x2.0p	213.5	557.0	196.0	M6 x1.0p 12.0 MIN	F10	4 OFF M10 x1.5p ON 102.0 P.C.D.	Ø 69.97/69.85 x3.0/2.6 HIGH	23.0
100	102.0	299.26 297.54	149.20	147.10 146.30	73.05 70.39	30.27	28.20	26.6 26.5	33.2 33.0	M36 x2.0p	274.8	850.0	256.0	M8 x1.25p 12.0 MIN	F12	4 OFF M12 x1.75p ON 125.0 P.C.D.	Ø 84.97/84.85 x3.0/2.6 HIGH	51.0

Technical Information

Valve Pressure and Temperature Ratings

Body / Connector Material	Temperature Range °C	Standard Material	
		44 Series	459 Series
(4) Carbon Steel	-29 to 300	•	–
(5) Low temp Carbon Steel	-46 to 300	–	•
(6) Stainless Steel	-196 to 300	•	•
Body Seal Material	Temperature Range °C	Max Pressure (Bar)	
		44 Series	459 Series
(T) PTFE	-50 to 260	102	50
(Z) Graphite	-196 to 300	102	50
(M) S-Gasket, 316+PTFE	-196 to 260	90	50
(G) S-Gasket, 316+Graphite	-196 to 300	90	50
(B) Buna Nitrile	-40 to 110	102*	50
(V) Viton	-20 to 250	102*	50
(E) EPDM	-50 to 125	102*	50
(S) Silicon	-65 to 200	102*	50
Seat Material	Temperature Range °C	Max Pressure (Bar)	
		44 Series	459 Series
(T) PTFE	-30 to 230	69	50
(R) PTFE, 15% GF	-50 to 230	102	50
(H) PTFE, 25% GF	-80 to 260	102	50
(P) PTFE, Fluorofill	-80 to 260	102	50
(A) or (X) PEEK	-80 to 280	102	50
(Y) Delrin	-80 to 80	102	50
(U) UHMWPE	-80 to 80	102	50
(N) Alpha, 316+PTFE	-80 to 300	69	50
(G) Gamma, 316+Graphite	-80 to 300	69	50

The valve pressure and temperature ratings are made up from a combination of the body/end connector material, seat material and body seal material. The seat ratings are shown graphically on pages 8 and 9 but they need to be used in conjunction with the maximum and minimum ratings shown opposite.

- *The maximum pressure ratings of 44 series valves with O-ring seals and PED SEP are: DN8 to DN25 = 207 bar, DN32 to DN50 = 138 bar
- Note:** All 459 series seals have a limit of 250 °C max even though the body rating is 300 °C.

Flow Coefficients / Limiting Stem Input Torque (reduced bore)

Valve Size		Flow Coefficients		Equivalent Length of pipe		Limiting Stem Input torque Nm	
mm	in	Cv	Kv	Feet	Metres	316S16	17/4pH
8-15	¼-½	8.3	7.2	1.8	0.58	13.2	90
20	¾	13.6	11.8	5.5	1.67		
25	1	37.5	32.6	3	0.91	24.4	165
32	1¼	57	49.3	3.1	0.94		
40	1½	79.7	69.1	3.9	1.19	48.6	268
50	2	106	91.8	7.5	2.28		
65	2½	188	163	150	1.52	192	1187
80	3	435	377	7	2.13	336	1677
100	4	638	553	27	8.21	620	3540
150	6	675	585	41	12.47	1138	7758

Notes:

- When wrench is not fitted the flats on the stem, when parallel to the pipeline axis, denote ball open
- All 44/59 weld end valves are assembled with Buna O-ring body seals with the correct body seals supplied loose. See IOM
- For temperatures below -50 °C consult Flowserve
- Alternative materials are available on request. These include NAB, Duplex, Monel, Hastelloy, 254 SMO for either body, connector, ball or stem
- Valves containing PEEK, Delrin, or Metal seats are fitted with 17/4-PH stems as standard

Product Coding

Series A44/A59

A		B			C		D				E				F				G				H	
Size		Standard Variant			Series		-	Body	End	Ball	Stem	Seat	Seal	End 1		End 2		Special				Revision		
1	2	3	4	5	6	7	8	9	10	11	12	13	14	15	16	17	18	19	20	21	22	23	24	25

A - Size Digits 1, 2	B - Std Variant Digits 3, 4, 5	C - Series Digits 6, 7	D - Main Parts Digits 9,10,11,12	E - Seat and Seals Digits 13,14,15,16,17	F - End Connector Variants Digits 18, 19, 20	G - Special Build Digits 21, 22, 23, 24	H - Revision Digit 25
1/4" 08mm 02	Antistatic A	44 Series 44	Brass 1	PEEK A	Screwed NPT SEN	Vacuum P043	Denotes the revision of the product
3/8" 10mm 03		59 Series 59	Carbon St. 4	Buna B	Screwed BSPT SET	Oxygen Q822	
1/2" 15mm 05			Stainless St. 6	EPDM E	Screwed BSPP SEP	Tobacco P669	
3/4" 20mm 07			Special M	Metal Gamma G	Socket Weld Schedule 40 SWA	Ammonia Q797	
1" 25mm 10				25% Glass PTFE H	Socket Weld Schedule 80 SWC	Press. Relief Ball Q190	
1 1/4" 32mm 12				Metal Alpha N	Butt Weld Schedule 5 BW5	Std. de-grease P854	
1 1/2" 40mm 15				Fluorofill P	Butt Weld Schedule 10 BWE	Shrouded seats P225	
2" 50mm 20				15% Glass PTFE R	Butt Weld Schedule 40 BWA	O-Ring build P882	
				Virgin PTFE T	Butt Weld Schedule 80 BWC		
				UHMWPE U		BWG	
				Viton V		BWK	
				PolyPeek X		BWM	
				Delrin Y			

Series A459/A599

A		B			C		D				E				F				G				H	
Size		Standard Variant			Series		-	Body and End	Ball	Stem	Seat	Body Seal	Thrust Seal	Stem Seal	Gland Packing	End		Special				Revision		
1	2	3	4	5	6	7	8	9	10	11	12	13	14	15	16	17	18	19	20	21	22	23	24	25

A - Size Digits 1, 2	B - Std Variant Digits 3, 4, 5	C - Series Digits 6, 7, 8	D - Main Parts Digits 10, 11, 12	E - Seat and Seals Digits 13,14,15,16, 17	F - End Connector Variants Digits 18, 19, 20	G - Special Build Digits 21, 22, 23, 24	H - Revision Digit 25
2" 50mm 20	Antistatic A	459 Series 459	Carbon St. 5	PEEK A	Screwed NPT SEN	Vacuum P043	Denotes the revision of the product
2 1/2" 65mm 25		599 Series 599	Stainless St. 6	Buna B	Screwed BSPT SET	Oxygen Q822	
3" 80mm 30			Special M	35% Carbon PTFE C	Screwed BSPP SEP	Tobacco P669	
4" 100mm 40				EPDM E	Socket Weld Schedule 40 SWA	Ammonia Q797	
6" 150mm 60				Metal Gamma G	Socket Weld Schedule 80 SWC	Press. Relief Ball Q190	
				25% Glass PTFE H	Butt Weld Schedule 5 BW5	Std. de-grease P854	
				Metal Alpha N	Butt Weld Schedule 10 BWE	Shrouded seats P225	
				Fluorofill P	Butt Weld Schedule 40 BWA	O-Ring build P882	
				15% Glass PTFE R	Butt Weld Schedule 80 BWC		
				Virgin PTFE T		BWG	
				UHMWPE U		BWK	
				Viton V		BWM	
				PolyPeek X			
				Delrin Y			
				Graphite Z			
				25% Glass PTFE 7			

Ancillaries

Flowserve can supply a range of ancillary equipment such as lockable wrenches, stem extensions, spring return handles etc.



Flowserve Flow Control (UK)
Burrell Road
Haywards Heath
West Sussex United Kingdom RH16 1TL
Phone: +44 1444 314400
Fax: +44 1444 314401

Contact:

For more information about Flowserve Corporation, visit
www.flowserve.com or call USA 1 800 225 6989

FCD WCENBR0003-02-A4 04/16

Flowserve Corporation has established industry leadership in the design and manufacture of its products. When properly selected, this Flowserve product is designed to perform its intended function safely during its useful life. However, the purchaser or user of Flowserve products should be aware that Flowserve products might be used in numerous applications under a wide variety of industrial service conditions. Although Flowserve can (and often does) provide general guidelines, it cannot provide specific data and warnings for all possible applications. The purchaser/user must therefore assume the ultimate responsibility for the proper sizing and selection, installation, operation, and maintenance of Flowserve products. The purchaser/user should read and understand the Installation Operation Maintenance (IOM) instructions included with the product, and train its employees and contractors in the safe use of Flowserve products in connection with the specific application.

While the information and specifications contained in this literature are believed to be accurate, they are supplied for informative purposes only and should not be considered certified or as a guarantee of satisfactory results by reliance thereon. Nothing contained herein is to be construed as a warranty or guarantee, express or implied, regarding any matter with respect to this product. Because Flowserve is continually improving and upgrading its product design, the specifications, dimensions and information contained herein are subject to change without notice. Should any question arise concerning these provisions, the purchaser/user should contact Flowserve Corporation at any one of its worldwide operations or offices.

© 2015 Flowserve Corporation, Irving, Texas, USA. Flowserve and Worcester Controls are registered trademarks of Flowserve Corporation.