



***Worcester 5 Series
BS 5351 Approved Flanged Ball Valves***



Experience In Motion

Flowserve Worcester is proud to announce the introduction of its new 519/529 range of ball valves which replaces the DN 15 - 50 sizes of the proven Series 51/52. The 519/529 has all the benefits of the 51/52 and in addition features an ISO 5211 mounting platform as well as the characteristics of full bore for sizes 15 - 40mm.

The 519/529 series has been independently third party type approved to BS 5351, including fire testing to BS EN 10497. The 519/529 is also available with the API 6D monogram upon request.

Anti-blowout Stem

Inserted from inside of valve body for greater safety.

Actuator mounting

Conforms to ISO 5211 for ease of actuation.

Anti-static stem design

Ensures electrical continuity between ball and body

Seats

Wide range of seat materials to suit customer applications.

Insert

Screwed insert designed to withstand full line differential pressure.

Ball

316 stainless steel as standard with pressure equalising equalising hole to balance cavity pressure when valve is open. Parallel ported ball maximises flow and minimises pressure drop (DN 15 - 50 only).

Body seals

PTFE as standard with firesafe integrity maintained with metal to metal secondary seal.

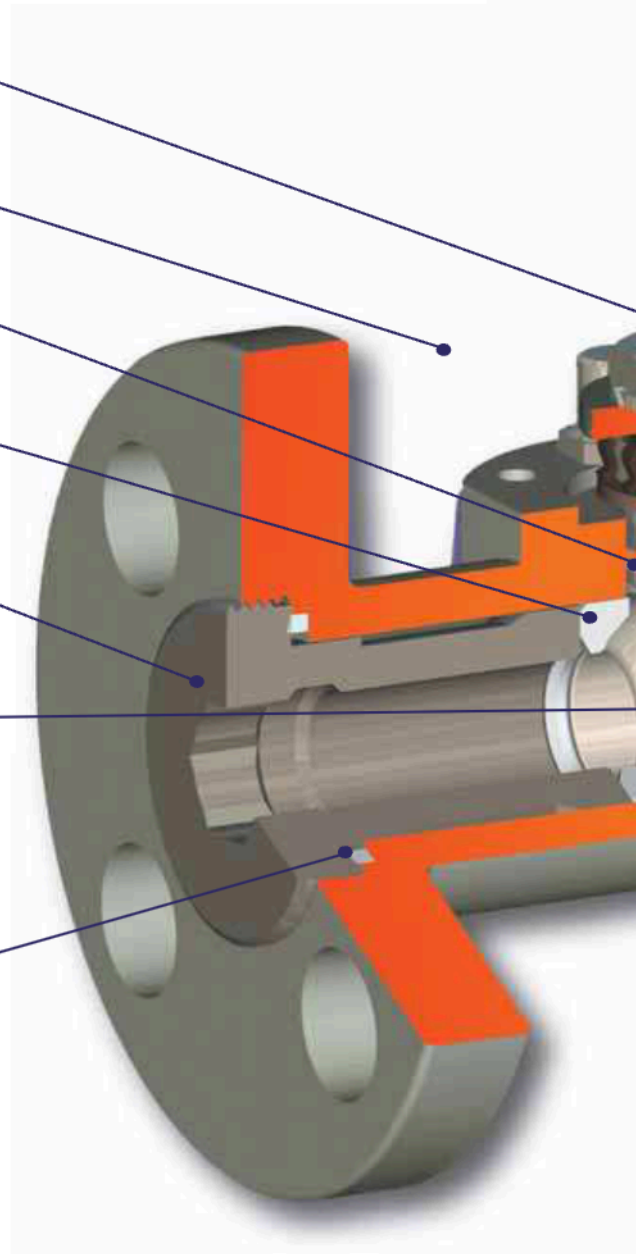

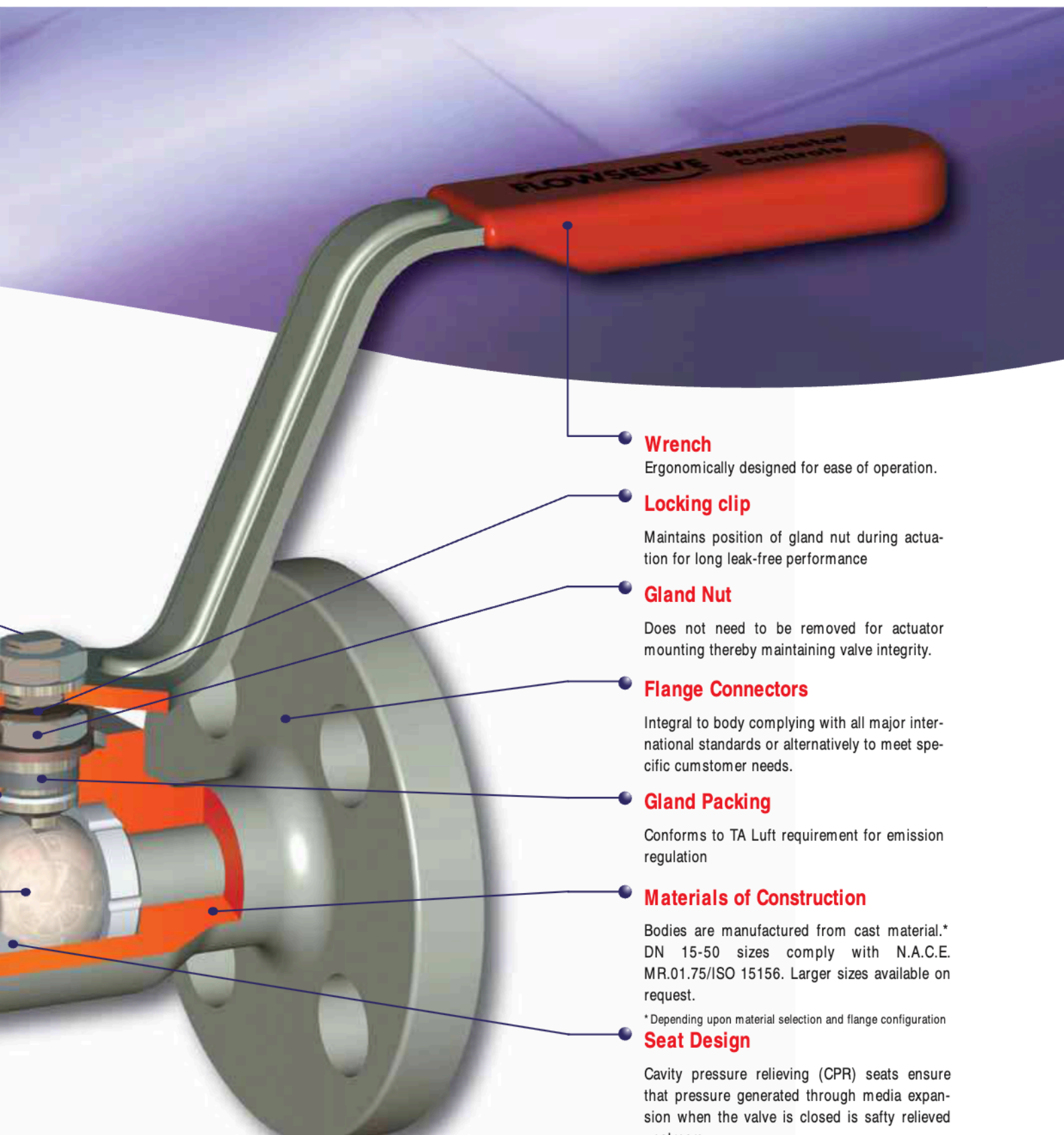

Wrench

Ergonomically designed for ease of operation.

Locking clip

Maintains position of gland nut during actuation for long leak-free performance

Gland Nut

Does not need to be removed for actuator mounting thereby maintaining valve integrity.

Flange Connectors

Integral to body complying with all major international standards or alternatively to meet specific customer needs.

Gland Packing

Conforms to TA Luft requirement for emission regulation

Materials of Construction

Bodies are manufactured from cast material.* DN 15-50 sizes comply with N.A.C.E. MR.01.75/ISO 15156. Larger sizes available on request.

* Depending upon material selection and flange configuration

Seat Design

Cavity pressure relieving (CPR) seats ensure that pressure generated through media expansion when the valve is closed is safely relieved upstream.

Parts / Materials List

51 / 52 (80-200mm)

519 / 529 (15-50mm)

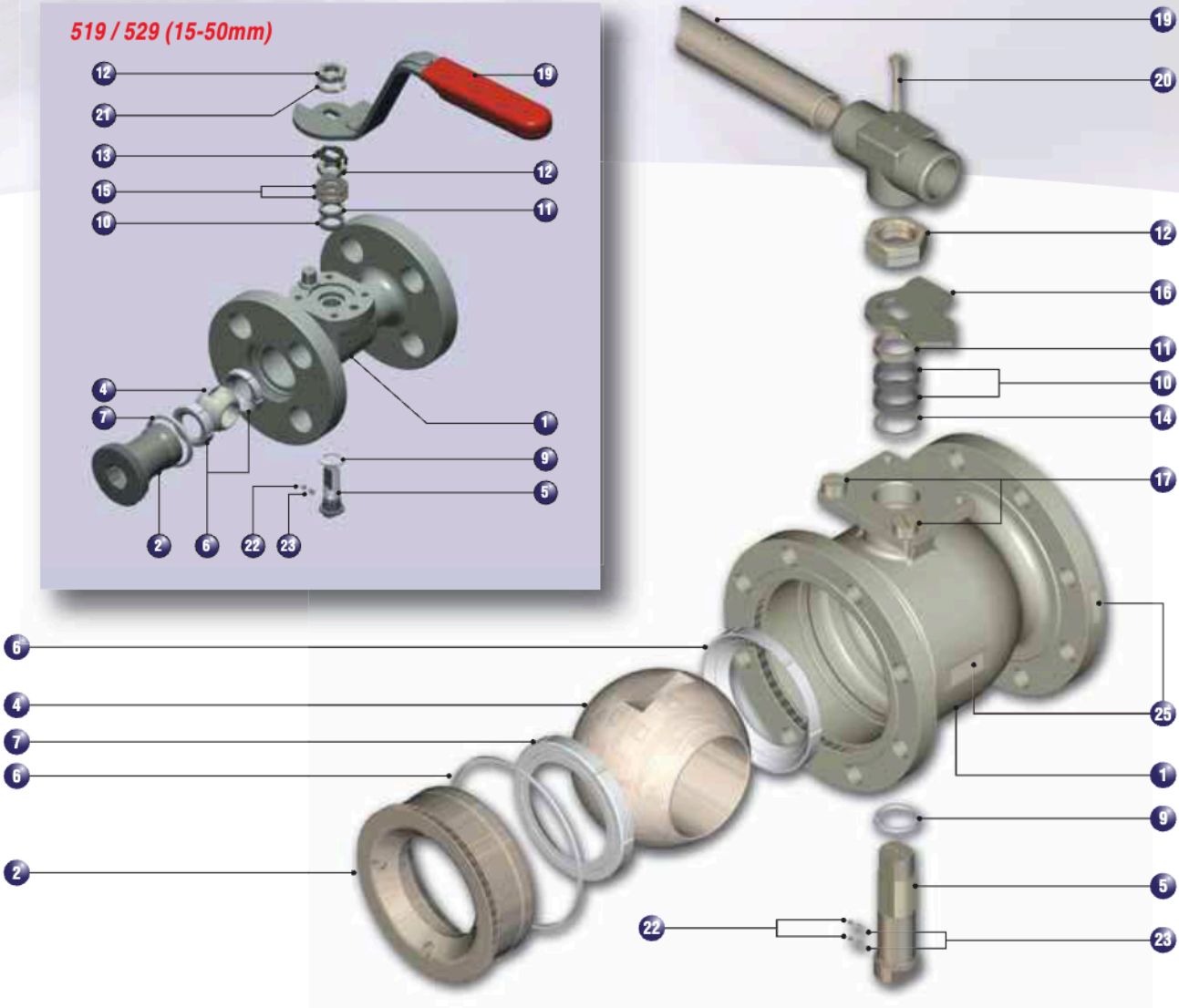

ITEM	DESCRIPTION	MATERIAL
1	Body	Stainless Steel ASTM A351 CF8M Carbon Steel ASTM A216 WCB
2	Insert	Stainless Steel ASTM A351 CF8M/316/Carbon Steel BS 970 070M20/ASTM A352 LCB
3	Body Connector	Stainless Steel/Carbon Steel ASTM A351 CF8M ASTM A216 WCB
4	Ball	Stainless Steel ASTM A351 CF8M/316
5	Stem	Stainless Steel 316
6*	Seat Ring	PTFE Virgin, PTFE 15% / 25% glass filled, Fluorofill, PEEK, metal or other options
7*	Body Seal	PTFE Virgin (15-50mm) PTFE 25% glass filled (80-200mm)
8*	Secondary Body Seal	Stainless Steel/Flexible Graphite
9*	Stem Thrust Seal	PTFE 25% glass filled
10*	Gland Packing	Flexible Graphite
11	Gland	Stainless Steel
12	Gland / Wrench Nut	Stainless Steel (8-50mm) Carbon Steel/Stainless Steel (80-250mm)
13*	Gland Nut Locking Clip	Carbon Steel Rustproofed

55 / 56 (65-250mm)

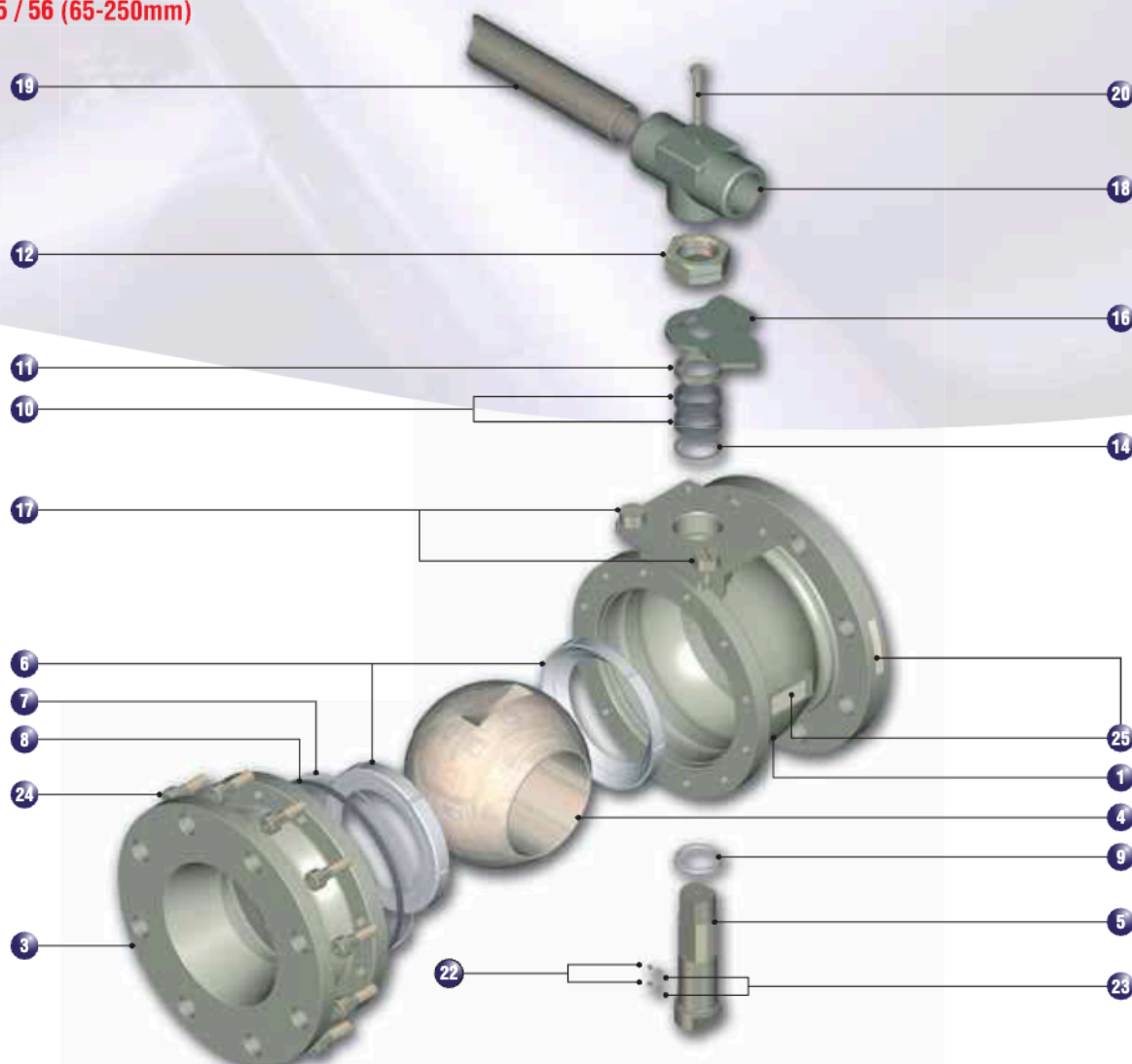

ITEM	DESCRIPTION	MATERIAL
14	Stem Location Washer	Stainless Steel
15*	Disc Spring	Stainless Steel
16**	Indicator Stop	Stainless Steel/Carbon Steel Rustproofed
17	Stop Pin	Stainless Steel/Carbon Steel
18**	Wrench Head	Malleable Iron
19**	Wrench	Stainless Steel 15-50mm, Carbon Steel 80-200mm
20**	Wrench Fixing Bolt	Stainless Steel
21	Spring Washer	Stainless Steel
22	Anti-static Plunger (See Note 4 on page 10)	Stainless Steel
23	Anti-static Spring (See Note 4 on page 10)	Stainless Steel
24	Body Connector Screw	Carbon Steel
25	Identification Plate	Stainless Steel

* Items marked thus denote component supplied in repair kit

** Wrench assembly not fitted on size 250mm

Pressure/Temperature Ratings

PTFE Seats (T)

Virgin PTFE is the most common sealing material and is suitable for almost all media as it has excellent chemical resistance.

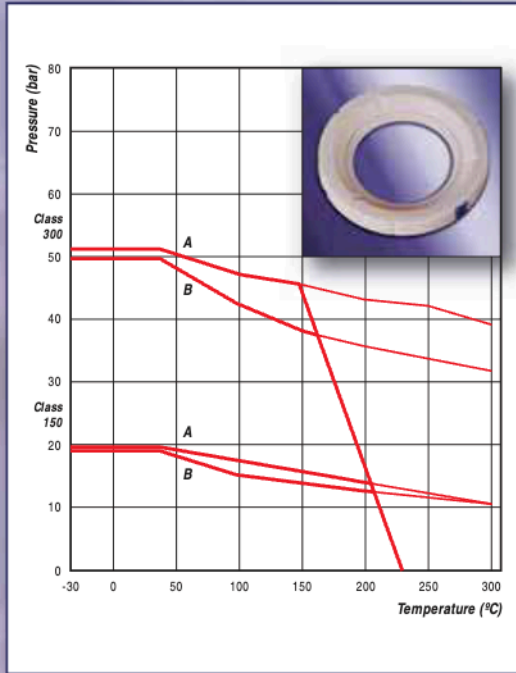

15% Glass Filled PTFE (R)

Glass re-inforced PTFE seats are stronger than virgin and have higher pressure / temperature ratings. Chemical resistance as per virgin PTFE.

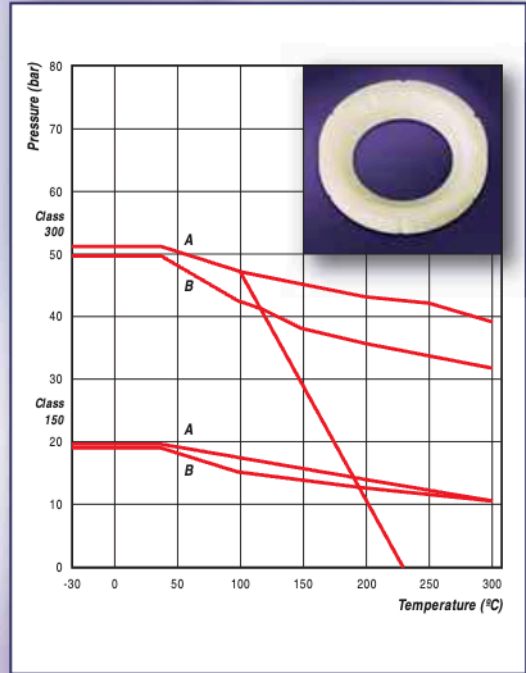

25% Glass Filled PTFE (H)

Glass re-inforced PTFE material offering a greater pressure / temperature capability than the R seat.

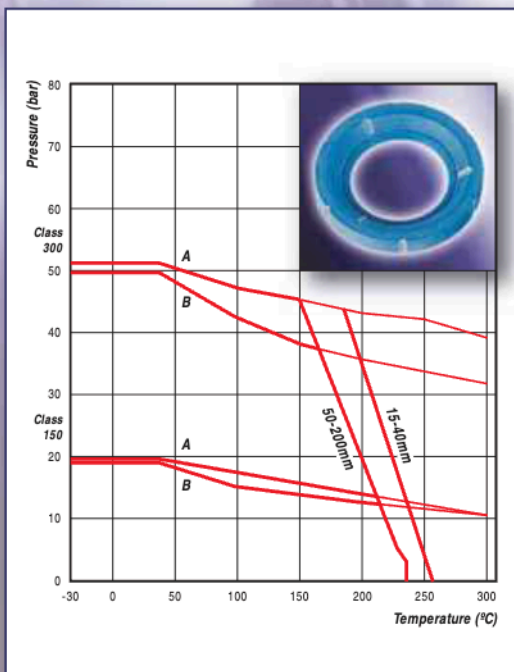

Fluorofill (P)

Carbon, glass and graphite filled PTFE material, an excellent seat material for steam and thermal services. Due to its high cycling capabilities, it is the recommended soft seat for modulating control applications.

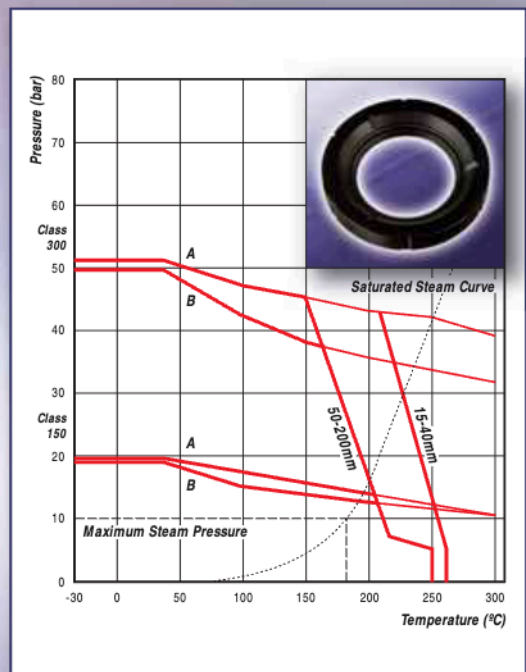

Pressure/Temperature Ratings

UHMWPE (U)

Ultra High Molecular Weight Polyethylene offers good performance characteristics in applications where PTFE is not suitable (for example on tobacco duty). It also has good abrasion resistance.

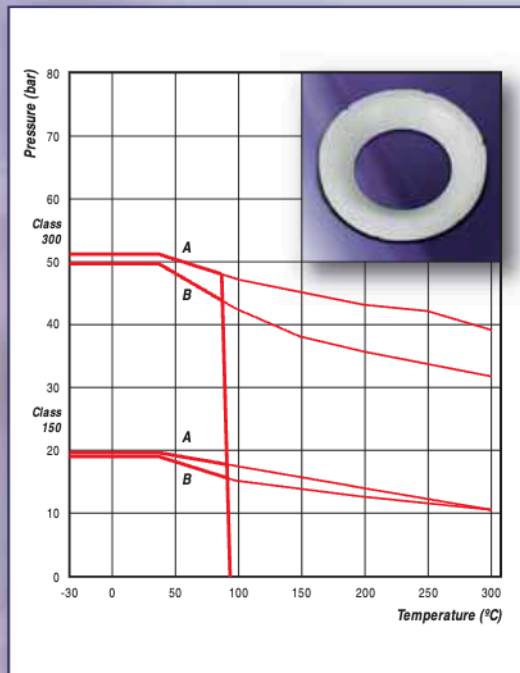

PEEK (A - DN15-25) (X - DN32-150)

PEEK is Poly Ether Ether Ketone, a material which demonstrates outstanding pressure capabilities at elevated temperatures. PEEK has excellent chemical and abrasion resistance.

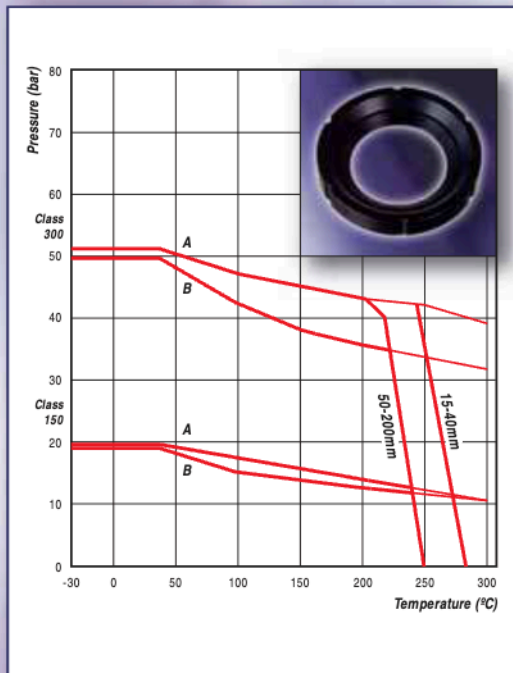

Metal - Alpha (N)

A 316L sintered metal seat impregnated with PTFE, this material combines the strength and abrasion resistance of metal with the lubrication properties of PTFE. A graphite-impregnated metal seat is also available.

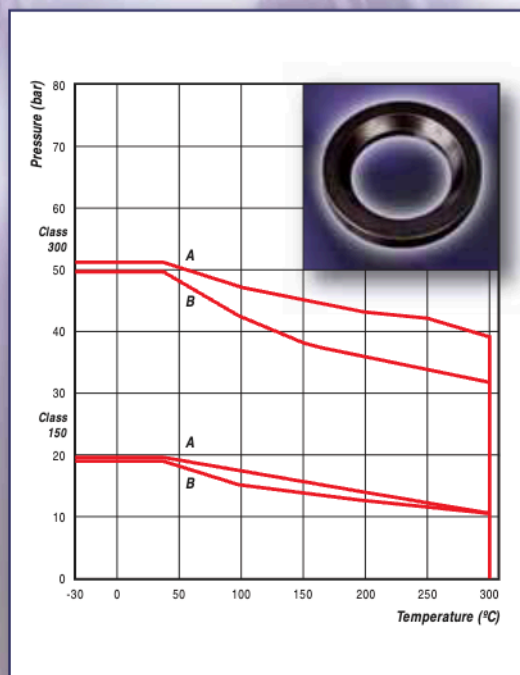

Key:
 A = Carbon Steel Body Rating
 B = Stainless Steel Body Rating
 (in accordance with BS EN 1759)

Dimensions (mm)

519 / 529

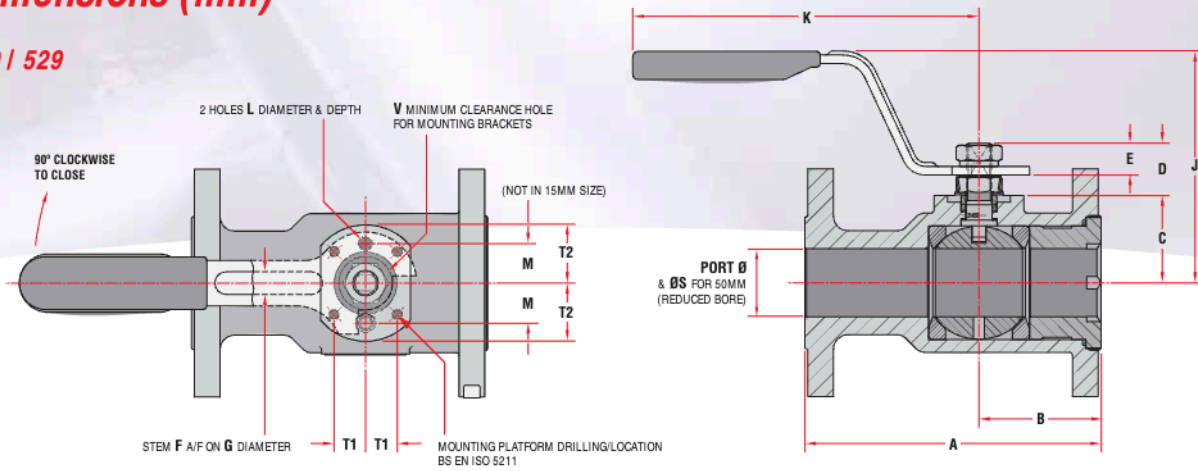

VALVE SIZE	PORT Ø MIN.	A		B	C	D	E	STEM		J	K	L THREAD & DEPTH	M	S	T1	T2	V	MOUNTING PLATFORM (ISO 5211)		APPROX. WEIGHT (kg)		
		F519	F529					F A/F	G THREAD									PLATFORM HOLES	PLATFORM RECESS	F519	F529	
15	13.7	108.0	140.0	52.5	23.27 23.01	17.56 16.86	10.69 10.19	5.54 5.46	3/8"-24 UNF	100.3	155.0	M6 x1.0p 9.2 MIN.	15.9	-	19.0	23.0	19.5	F03	4 OFF M5 x0.8p x8.0 DEEP MIN ON 36.0 P.C.D.	Ø 25.15 / 25.02 x2.36 / 1.73 DEEP	1.8	2.2
20	20.0	117.0	152.0	57.0	32.34 32.08	23.76 22.92	15.19 14.69	7.54 7.47	7/16"-20 UNF	112.8	168.0	M8 x1.25p 9.7 MIN.	20.65	-	22.0	27.0	22.5	F04	4 OFF M5 x0.8p x8.0 DEEP MIN ON 42.0 P.C.D.	Ø 30.15 / 30.02 x4.28 / 3.50 DEEP	2.4	3.5
25	25.3	127.0	165.0	63.0	37.11 36.85	23.74 22.90	15.19 14.69	7.54 7.47	7/16"-20 UNF	117.6	168.0	M8 x1.25p 9.7 MIN.	20.65	-	22.0	27.0	22.5	F04	4 OFF M5 x0.8p x8.0 DEEP MIN ON 42.0 P.C.D.	Ø 30.15 / 30.02 x4.28 / 3.50 DEEP	3.2	4.6
40	37.7	165.0	190.0	68.0	48.76 48.50	29.55 28.71	18.39 17.89	8.71 8.64	9/16"-18 UNF	133.6	193.0	M8 x1.25p 9.7 MIN.	22.25	-	25.0	32.5	29.5	F05	4 OFF M6 x1.0p x10.0 DEEP MIN ON 50.0 P.C.D.	Ø 30.15 / 30.02 x4.03 / 3.26 DEEP	5.8	8.6
50	37.7	178.0	216.0	70.8	47.06 46.80	31.25 30.41	18.39 17.89	8.71 8.64	9/16"-18 UNF	133.6	193.0	M8 x1.25p 9.7 MIN.	22.25	50.0	27.0	38.75	29.5	F05	4 OFF M6 x1.0p x10.0 DEEP MIN ON 50.0 P.C.D.	Ø 35.15 / 35.02 x2.33 / 1.56 DEEP	8.2	10.8

51 / 52

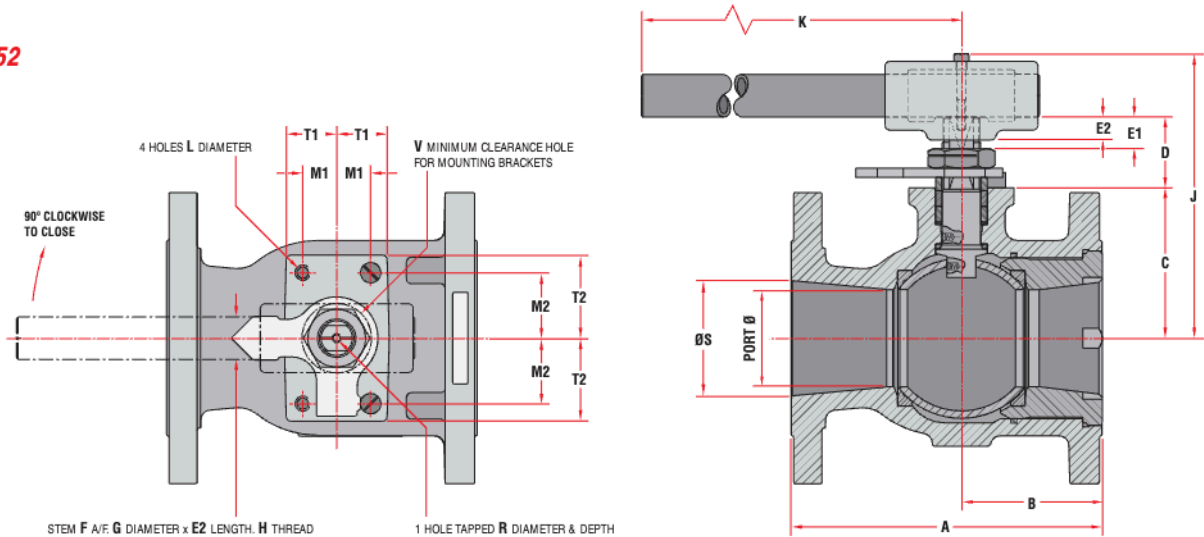

VALVE SIZE	PORT Ø MIN.	A		B	C	D	E1 MIN.	E2 MIN.	STEM		J	K	L THREAD	M1	M2	R THREAD & DEPTH	S	T1	T2	V	APPROX. WEIGHT (kg)		
		F51	F52						F A/F	G Ø											H THREAD	F51	F52
80	63.1	203.0	283.0	91.9	98.55 98.05	47.43 45.63	18.85	15.9	15.87 15.77	23.00 22.75	1"-14 UNS	184.5	350.0	M10 x1.5p	22.22	42.86	M6 x1.0p x1.9 MIN	77.0	33.8	54.4	46.0	18.0	26.0
100	82.1	229.0	305.0	101.4	114.25 113.75	47.43 45.63	18.85	15.9	15.87 15.77	23.00 22.75	1"-14 UNS	200.0	558.0	M10 x1.5p	22.22	42.86	M6 x1.0p x9.0 MIN	101.0	33.8	54.4	46.0	28.0	41.0
150	110.7	267.0	403.0	107.8	157.55 157.05	69.78 67.98	31.68	25.4	23.80 23.70	35.30 35.05	1½"-12 UNF	282.5	850.0	M12 x1.75p	38.10	50.80	M8 x1.25p x11.0 MIN	153.0	51.2	63.9	68.0	52.0	76.0
200	144.3	292.0	419.0	144.3	185.05 184.55	69.78 67.98	31.68	25.4	23.80 23.70	35.30 35.05	1½"-12 UNF	310.0	850.0	M12 x1.75p	38.10	50.80	M8 x1.25p x11.0 MIN	202.5	51.2	63.9	68.0	82.0	124.0

55 / 56

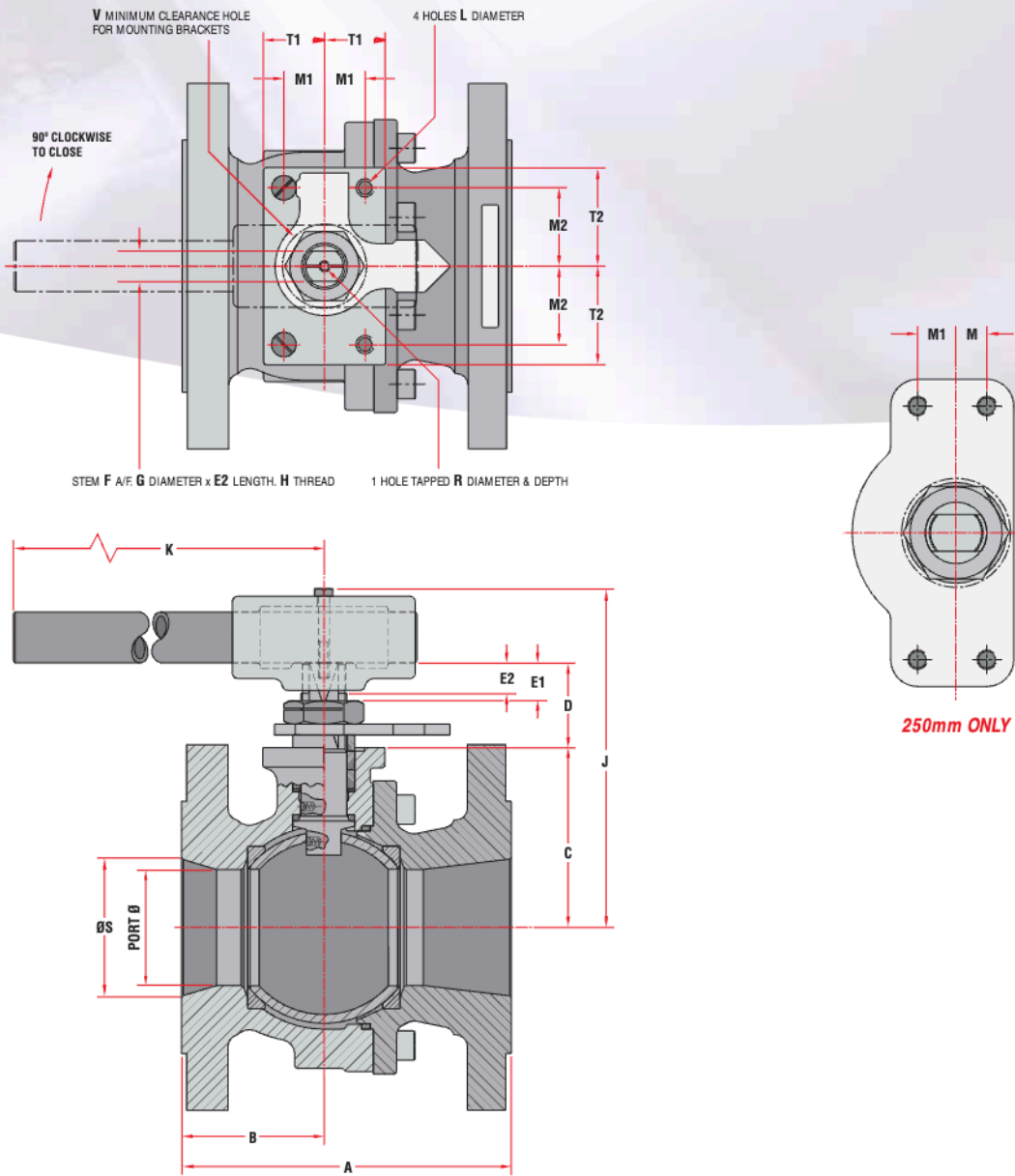

VALVE SIZE	PORT Ø MIN.	A	B	C	D	E1 MIN.	E2 MIN.	F A/F	STEM G Ø	H THREAD	J	K	L THREAD	M1	M2	R THREAD & DEPTH	S	T1	T2	V	APPROX. WEIGHT (kg)
65	50.5	190.0	68.0	74.4 74.0	42.6 40.6	13.68	-	14.00 13.85	-	M20 x1.5p	141.5	225.0	M8 x1.25p	16.0	35.0	M6 x1.0p x10.0 MIN	65.0	26.0	45.0	40.0	16.0
80	63.1	203.2	77.8	98.55 98.05	47.43 45.63	18.85	15.9	15.87 15.77	23.00 22.75	1"-14 UNS	184.5	350.0	M10 x1.5p	22.22	42.86	M6 x1.0p x9.0 MIN	77.0	33.3	54.0	46.0	20.0
100	82.1	228.6	84.1	114.25 113.75	47.43 45.63	18.85	15.9	15.87 15.77	23.00 22.75	1"-14 UNS	200.0	558.0	M10 x1.5p	22.22	42.86	M6 x1.0p x9.0 MIN	101.0	33.3	54.0	46.0	28.0
150	110.7	266.7	120.6	157.55 157.05	69.78 67.98	31.68	25.4	23.80 23.70	35.30 35.05	1½"-12 UNF	282.5	850.0	M12 x1.75p	38.10	50.80	M8 x1.25p x11.0 MIN	153.0	50.8	63.5	68.0	60.0
200	144.3	292.0	136.4	185.05 184.55	69.78 67.98	31.68	25.4	23.80 23.70	35.30 35.05	1½"-12 UNF	310.0	850.0	M12 x1.75p	38.10	50.80	M8 x1.25p x11.0 MIN	202.5	50.8	63.5	68.0	85.0

VALVE SIZE	PORT Ø MIN.	F55	A	F56	B	C	D	E1 MIN.	E2 MIN.	F A/F	STEM G Ø	H THREAD	L THREAD	M	M1	M2	P	S	V	APPROX. WEIGHT (kg)	
250	200.0	330.2	457.2	165.1	228.5	260.65 260.15	83.58 81.53	26.18	30.7	30.40 30.15	44.58 44.32	2"-6 UN	M16 x2.0p	25.4	31.75	104.78	463.5	255.6	90.0	145.0	208.0

Standards of Compliance

Valve Specification	BS 5351, valves for the petroleum industry. Lloyds Register type approved. API 6D monogrammed product. License product can be supplied upon request
Flanges	BS EN 1759 Class 150 / Class 300 BS EN 1092, BS 4504 PN16 / PN40
Face to Face Lengths	ANSI B16.10 BS 2080
Pressure Test Specification	BS EN 12266-1, BS EN 17292
Firesafe Specification	ISO 10497, API 6FA, API 607 5th Edition
Quality Assurance	ISO 9001
Sour Gas Applications	NACE MR.01.75 (15 to 100mm as standard)

Notes

1. When wrench not fitted, flats on stem when parallel to pipeline axis denote open position.
2. Installation, Operating and Maintenance instructions are available on request.
3. For valve sizes 15-50mm only one anti-static ball and spring is fitted.

Flow Coefficients

Valve Size		Model	Flow Coefficients	
mm	in		Cv	Kv
15	½	519/529	32	27
20	¾	519/529	54	46
25	1	519/529	94	80
40	1½	519/529	254	219
50	2	51/52	130	112.5
80	3	51/52	350	303
100	4	51/52	720	623
150	6	51/52	1020	882
200	8	51/52	1800	1557
250	10	51/52	2970	2560
See Note 3			Cv – Flow in US GPM Pressure – psi Kv – Flow in M ³ /hr Pressure – bar	

Important Information

The information given in the pressure/temperature graphs indicates the maximum performance capabilities of these seat materials. The full potential of virgin and re-inforced PTFE can be realised in the standard Worcester valve build. For more demanding applications requiring the greater pressure/temperature capabilities of the other seat materials, it is essential that the appropriate valve build is specified. Examples of these applications include the following:

- Thermal Fluids
- Nuclear Service
- Oxygen Service
- Tobacco
- Ammonia
- Helium
- Toxic Chemicals (e.g. Chlorine, Hydrogen Peroxide, Phosgene etc.) - Envirosafe Build
- Vacuum Service

and many more.

To ensure that the correct valve is supplied, please consult Flowserve Flow Control.

Product Coding

519 / 529

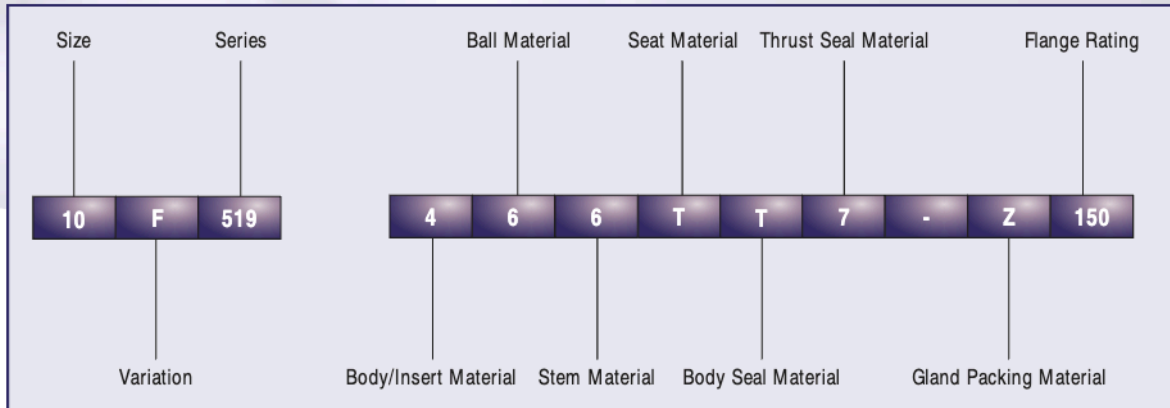

51 / 52 or 55 / 56

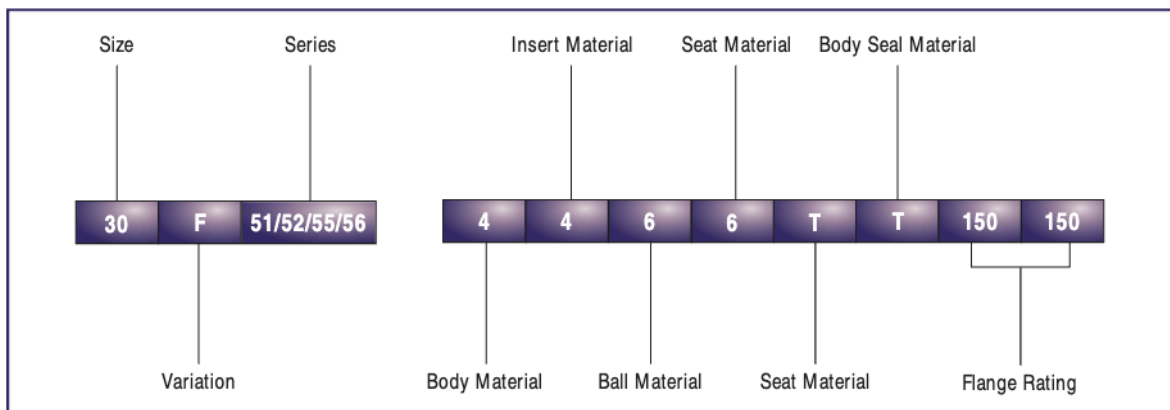

Other Flanged Valves



819/829 Series

With the Series 819/829, Worcester brings to the market a full bore valve designed type approved to BS 5351 which combines low cost of ownership and long service life with high operational safety and a range of features which now sets the standards for others to follow.



Enviro-Safe E51/52

With the Enviro-Safe E51/52, Worcester's primary aim was to design a range of high integrity Class 150/300 ball valves to prevent external leakage in demanding applications such as highly toxic media (phosgene, chlorine etc.) or with very costly media where wastage is unacceptable. Available in sizes from 15 - 150mm.



18/19 Series

The modular Series 18/19 multi-way valve satisfies the need for diverting media through a number of flow paths. Currently used extensively on a variety of chemical and food processes, the potential applications for this firesafe valve are extensive. When compared with a plug valve for example, the Series 18/19 offers numerous advantages, including bubble tightshut-off, long sealing life, extended temperature range, ease of maintenance, material range, no need for sealant etc.



C51/52 Series

The Series C51/52 is a fully designed cryogenic flanged valve for liquid gases (propane, butane, etc.), as well as thermal cycling fluids such as Dowtherm which involve both high and low temperatures.



53/54 Series

The Series 53/54 is Worcester's range of metric, integrally flanged valves conforming to DIN 3202. The valves are designed to BS 5159 and are supplied as F53/54 anti-static and fire rated.

FCD WCEBR0004-01 Printed in Germany. (Replaces PB14 Rev 11/02)

Due to continuous development of our product range, we reserve the right to alter the dimensions and information contained in this leaflet as required. Information given in this leaflet is made in good faith and based upon specific testing but does not, however, constitute a guarantee.



Flowserve Flow Control (UK) Ltd.
Worcester Controls
Burrell Road, Haywards Heath
West Sussex RH16 1TL
United Kingdom
Telephone: +44 (0)1444 314400
Telefax: +44 (0)1444 314401
Email: wvukinfo@flowserve.com