



***Worcester Controls E51/52
Enviro-Safe High Integrity Flanged Ball Valves***



Experience In Motion

General Description

With environmental protection and control established as a major issue for the future, Flowserve Worcester Controls provides a range of high integrity valves: the Enviro-Safe E51/52.

Worcester's primary aim was to design a range of Class 150/300 ball valves to prevent external leakage in demanding applications such as highly toxic media (phosgene, chlorine etc) or with very costly media where wastage is unacceptable.

Experience has shown that repeated valve operation eventually causes wear in the stem sealing area and this leads ultimately to external leakage.

Worcester's Enviro-Safe range of ball valves has a high cycle life at an increased range of temperatures and pressures. At the heart of the valve's high integrity performance is its dual stem packing.

The unique primary seal is designed so that it will always fail in service BEFORE the secondary seal. With a monitoring port drilled through to a lantern ring which is located between the two sealing stages, primary seal leakage can be detected whilst the secondary seals ensure overall integrity. This unique and foolproof stem packing design is live loaded with stainless steel disc springs and has been proven in testing to be bubble-tight on helium even after primary seal leakage. Primary seal integrity can then be restored by simply tightening down the gland plate.

The Enviro-Safe features two stem purge bosses. One is drilled and tapped to 1/8" BSPT standard thread that allows connection of instrumentation/sensing devices, while the optional second port allows through purging between the stem seals. In addition the one piece body eliminates unnecessary joints.

The Enviro-Safe valves are also available in firesafe versions EF51/52 or sour gas versions to NACE (MR. 0175/ISO 15156).

A further benefit allows automated versions to have the actuator removed without affecting the integrity of the valve seals.

Size Range

The Enviro-Safe comes in 8 sizes ranging from ½" to 6" (15mm-150mm).

Flanges

Integral to the valve body, flanges are rated ASME Class 150 for the E51 and ASME Class 300 for the E52. Flange dimensions are to BS EN 1759-1/ASME B16.5 and face to face lengths are to BS EN 558-2 table 6/ASME B16. 10.

Alternative metric flanges are available to BS EN 1092-1 (PN16/40).

Body Construction

The valves are all of one-piece design, and are available in either low temperature carbon steel or stainless steel as standard. Other materials are available.

Stem

The blow-out proof stem design is of a larger diameter than normal and is retained by a tamper-proof split ring. The stem is 316 stainless steel as standard, but other options can be supplied. Primary stem seals are PTFE in trapezoidal section, and secondary seals are PTFE chevron rings. Alternatively graphite seals are supplied for fire-safe and high temperature applications.

Ball

The ball is manufactured from 316 stainless steel as standard, and other materials, as required.

Seats

A range of seat materials is available to suit a wide variety of applications and include virgin PTFE, 15% glass-filled PTFE, Fluorofill, PEEK and metal (graphite impregnated 316 stainless steel). (Pressure/temperature ratings can be found on the back page).

Body Seals

½" to 2" (15-50mm): Virgin PTFE.

3" to 6" (80-150mm): 15% glass-filled PTFE.

Automation

All Enviro-Safe valves are designed to be simply and easily actuated.

Applications

The Enviro-Safe valve can be prepared for use on chlorine, including the supply of ball, stem and related parts in either Hastelloy or Monel as required.

In fact the Enviro-Safe has already established itself as THE valve for chlorine duty, being adopted as the site standard on a number of plants.

In addition the valve has proven itself in numerous applications

including phosgene, hexane, toluene, ethylene oxide, T.C.A.I.*, ionones, hydrogen, high temperature thermal fluids, super-heated steam and many others.

A further use for the Enviro-Safe is on high cycling duty, where the design of the valve ensures significantly extended life and minimal maintenance.

* *Tri-chloro-acetal-isocyanate.*

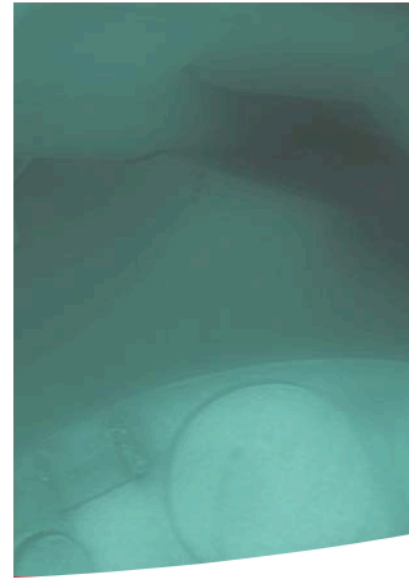

Design features of the Enviro-safe stem

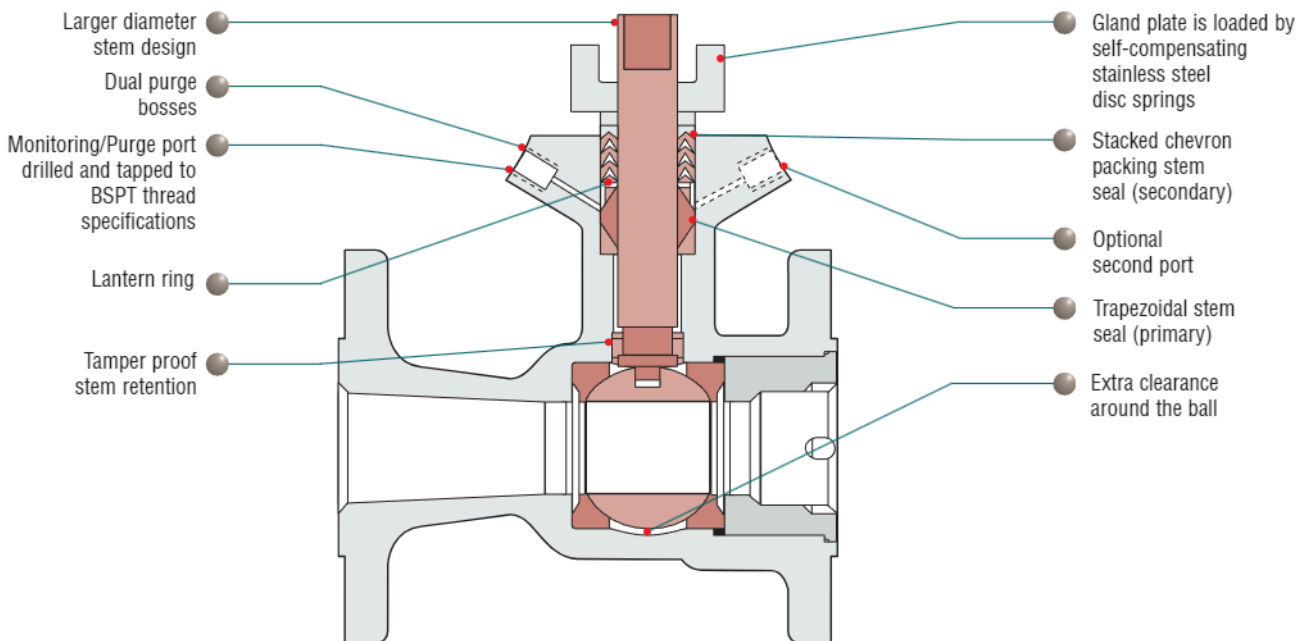

Features

- Primary and secondary stem sealing
- One-piece body casting
- Live loaded gland assembly
- Stem monitoring/purge port
- Blow-out proof stem
- Range of seat materials
- Integral body mounting platform

Benefits

- For ultimate sealing performance
- To minimise leak paths
- For long sealing life
- To monitor integrity
- For added safety
- For greater pressure/temperature capability
- For simpler actuation and in-line actuator removal

(15-50mm)

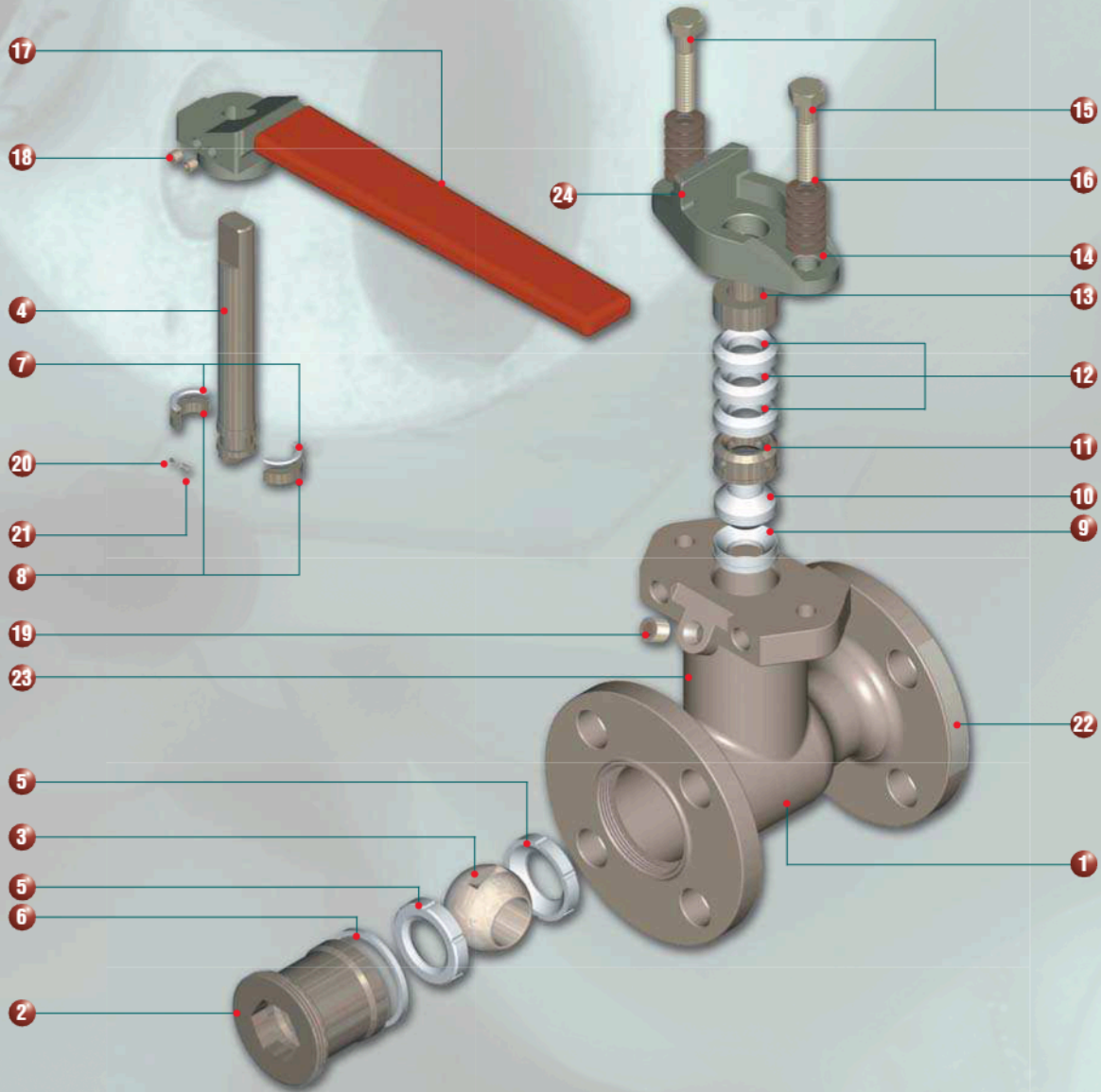

Parts/Materials List

ITEM	DESCRIPTION	MATERIAL	ITEM	DESCRIPTION	MATERIAL
1.	Body	Stainless Steel ASTM A351 CF8M (UNS J92900) Carbon Steel ASTM A352 LCB (UNS J03003)	11.	Lantern Ring	Stainless Steel
2.	Insert	15-25mm 40-50mm Stainless Steel AISI Type 316 Stainless Steel ASTM A479 316 (UNS S31600)	12.*	Chevron Ring	PTFE Virgin
3.	Ball	Stainless Steel ASTM A479 316 (UNS S31600) or ASTM A351 CF8M (UNS J92900)	13.	Follower 'T'	Stainless Steel
4.	Stem	Stainless Steel ASTM A479 316 (S31600)	14.	Gland Plate	Stainless Steel ASTM A473 CF8M (UNS J92900)
5.*	Seat Ring (Standard Variations)	T PTFE Virgin, R PTFE 15% Glass Filled H PTFE 25% Glass Filled P Fluorofill PTFE: 10% Glass, 15% Carbon Filled	15.	Gland Bolt	Stainless Steel ASTM A193 GR B8
6.*	Body Seal	PTFE Virgin	16.*	Disc Spring	Stainless Steel
7.*	Split Thrust Seal	Polybenzimidazole (PBI)	17.	Wrench	S.G. Iron
8.	Split Ring	Stainless Steel	18.	Set Screw	Carbon Steel
9.*	Filler Ring	PTFE Virgin	19.	Blanking Plug	Stainless Steel GR A4-70
10.*	629 Stem Seal	PTFE Virgin	20.	Anti-Static Ball	Stainless Steel
			21.	Anti-Static Spring	Stainless Steel
			22.	Identity Plate	Stainless Steel
			23.	Body Plate	Stainless Steel
			24.	Warning Label	Stainless Steel

* Items marked thus denote component supplied in repair kit

(80-200mm)

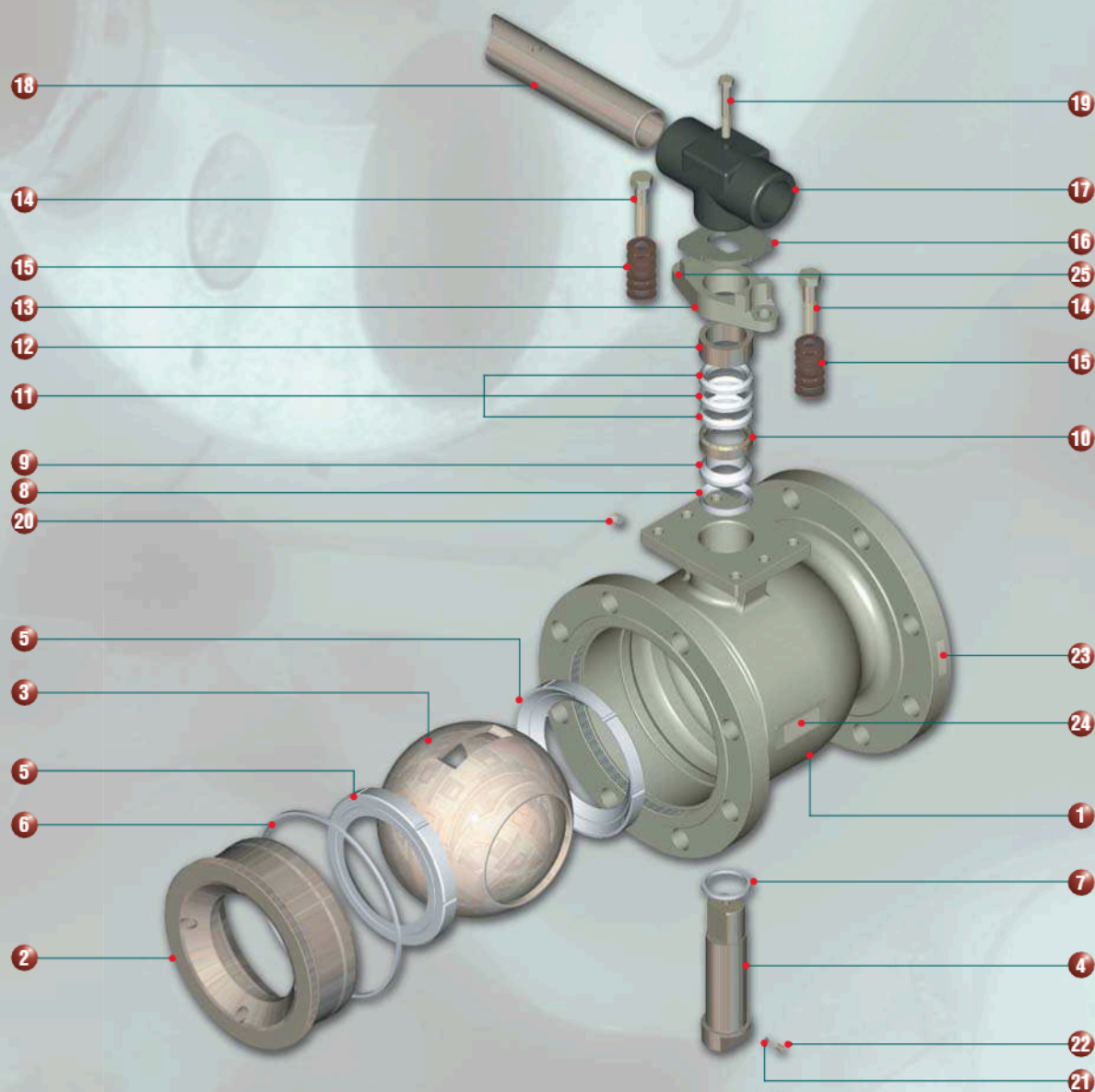

Parts/Materials List

ITEM	DESCRIPTION	MATERIAL	ITEM	DESCRIPTION	MATERIAL
1.	Body	Stainless Steel ASTM A351 CF8M (UNS J92900) Carbon Steel ASTM A352 LCB (UNS J03003)	11.*	Chevron Ring	PTFE Virgin
2.	Insert	80-200mm s/s 80 & 100mm c/s 150 & 200mm c/s Stainless Steel ASTM A479 316 (UNS S31600) Stainless Steel ASTM A479 316 (UNS S31600) Carbon Steel ASTM A350 LF2 (UNS K03011)	12.	Follower 'T'	Stainless Steel
3.	Ball	80 & 100mm 150 & 200mm Stainless Steel ASTM A351 CF8M (UNS J92900) Carbon Steel ASTM A240 316L (UNS S31603) or ASTM A312 TP316L	13.	Gland Plate	Stainless Steel ASTM A473 CF8M (UNS J92900)
4.	Stem	Stainless Steel AISI Type 316 (S31600)	14.	Gland Bolt	Stainless Steel ASTM A193 GR B8
5.*	Seat Ring (Standard Variations)	T PTFE Virgin, R PTFE 15% Glass Filled H PTFE 25% Glass Filled P Fluorofill PTFE: 10% Glass, 15% Carbon Filled	15.*	Disc Spring	Stainless Steel
6.*	Body Seal	PTFE 25% Glass Filled	16.	Stop Plate	Stainless Steel
7.*	Thrust Seal	PTFE 25% Glass Filled	17.	Wrench Head	S.G. Iron
8.*	Filler Ring	PTFE Virgin	18.	Wrench	Carbon Steel
9.*	629 Stem Seal	PTFE Virgin	19.	Hexagon Head Bolt	Stainless Steel
10.	Lantern Ring	Stainless Steel	20.	Blanking Plug	Stainless Steel GR A4-70
			21.	Anti-Static Ball	Stainless Steel
			22.	Anti-Static Spring	Stainless Steel
			23.	Identity Plate	Stainless Steel
			24.	Body Plate	Stainless Steel
			25.	Warning Label	Stainless Steel

* Items marked thus denote component supplied in repair kit

(15-50 mm)

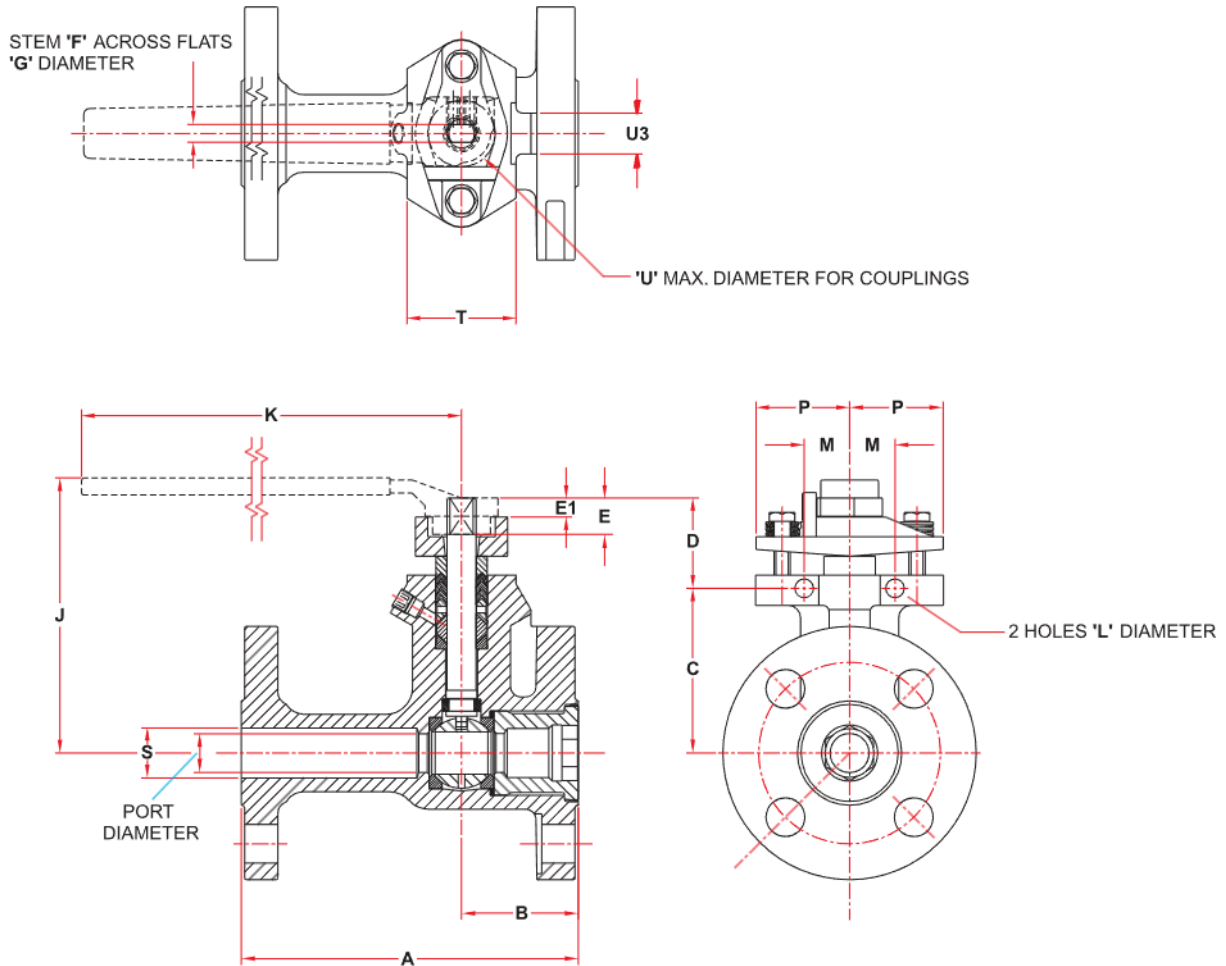

Valve Dimensions (mm)

Valve Size	Port Ø Min.	A		B	C	D	E	E1	STEM		J	K	L Ø	M	P	T	U	U3 Max.
		E51 CI 150	E52 CI 300						F A/F	G Ø								
DN15	14.1	108.0	140.0	46.0	70.1	45.01 42.81	18.16 17.40	12.0	7.52 7.39	11.13 11.00	124.0	203.0	9.3 9.0	22.23	45.8	49.5 49.0	32.0	17.5
DN20	14.1	117.0	152.0	46.0	70.1	45.01 42.81	18.16 17.40	12.0	7.52 7.39	11.13 11.00	124.0	203.0	9.3 9.0	22.23	45.8	49.5 49.0	32.0	17.5
DN25	19.0	127.0	165.0	57.2	80.7	44.72 43.19	18.16 17.40	9.0	8.71 8.58	14.30 14.17	134.5	203.0	9.3 9.0	22.23	45.8	50.05 49.80	32.0	17.5
DN40	30.1	165.0	190.0	62.3	97.0	48.57 47.05	19.43 18.67	9.0	12.70 12.57	19.05 18.92	160.0	254.0	11.3 11.0	28.58	55.0	70.20 69.95	32.0	17.5
DN50	36.4	178.0	216.0	67.9	101.9	48.51 46.98	19.43 18.67	9.0	12.70 12.57	19.05 18.92	164.5	254.0	11.3 11.0	28.58	55.0	70.20 69.95	32.0	-

(80-200mm)

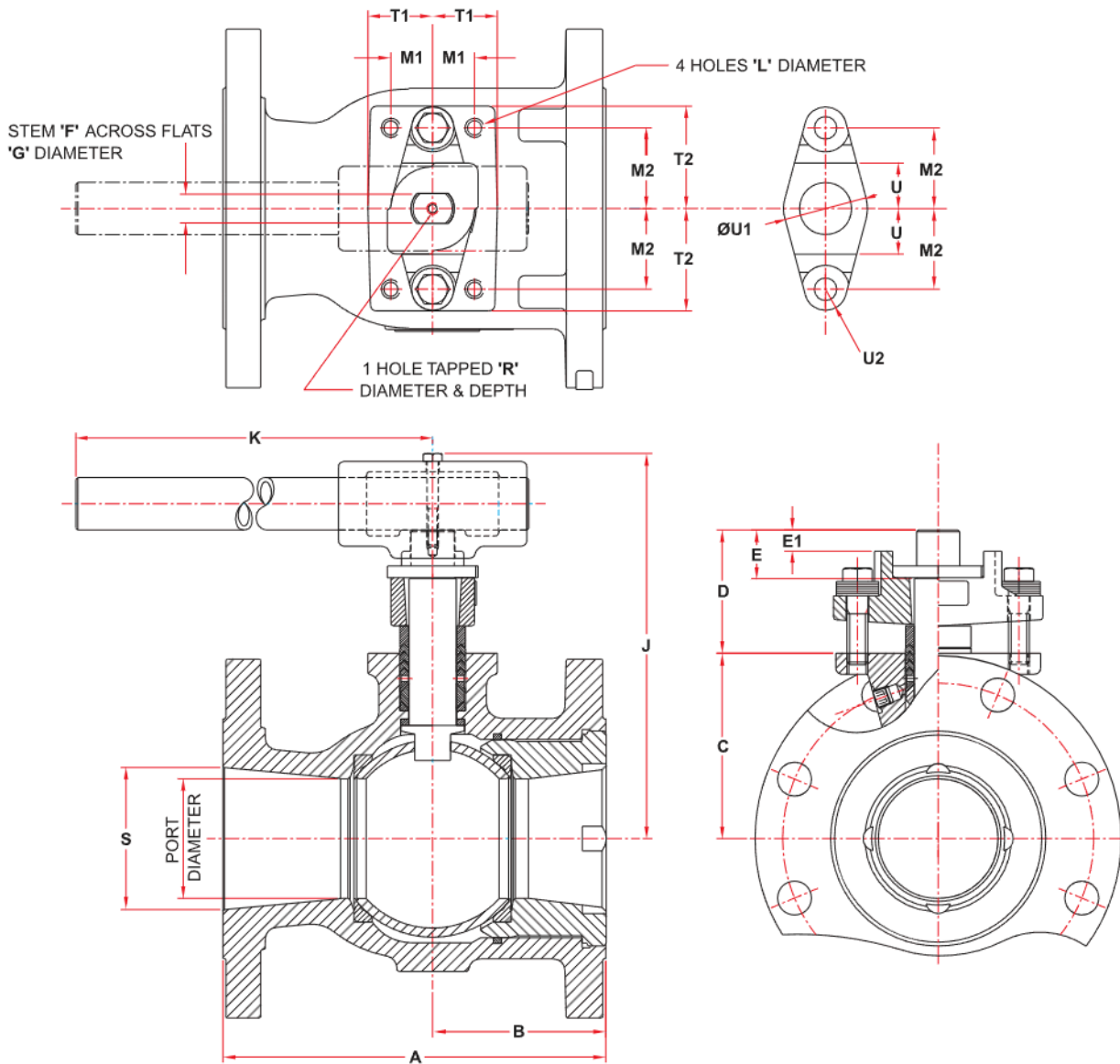

Valve Dimensions (mm)

Valve Size	Port Ø Min.	A		B	C	D	E Min.	E1 Min.	STEM		J	K	L Thread	M1	M2	R Thread & Depth	S Ø	T1	T2	U	U1	U2
		ES1 CI 150	ES2 CI 300						F A/F	G Ø												
DN80	63.1	203.0	283.0	91.9	98.55 98.05	64.75 62.98	25.53	13.0	15.87 15.77	23.0 22.75	201.7	350.0	M10x1.5p	22.22	42.86	M6x1.0p x9.0 Min.	77.0	33.8	54.4	47.5	44.83	11.56
DN100	82.1	229.0	305.0	101.4	114.25 113.75	64.75 62.98	25.53	13.0	15.87 15.77	23.0 22.75	217.4	558.0	M10x1.5p	22.22	42.86	M6x1.0p x9.0 Min.	101.0	33.8	54.4	47.5	44.83	11.56
DN150	110.7	267.0	403.0	107.8	157.55 157.05	74.73 72.96	34.93	25.0	23.80 23.70	35.30 35.05	287.0	850.0	M12x1.75p	38.10	50.80	M8x1.25p x11.0 Min.	153.0	51.2	63.9	65.0	61.47	14.60
DN200	144.3	292.0	419.0	144.3	185.05 184.55	74.73 72.96	34.93	25.0	23.80 23.70	35.30 35.05	314.5	850.0	M12x1.75p	38.10	50.80	M8x1.25p x11.0 Min.	202.5	51.2	63.9	65.0	61.47	14.60

Due to continuous development of our product range, we reserve the right to alter the dimensions and information contained in this leaflet as required

Pressure Temperature Ratings - Seat options

Virgin/Re-reinforced PTFE

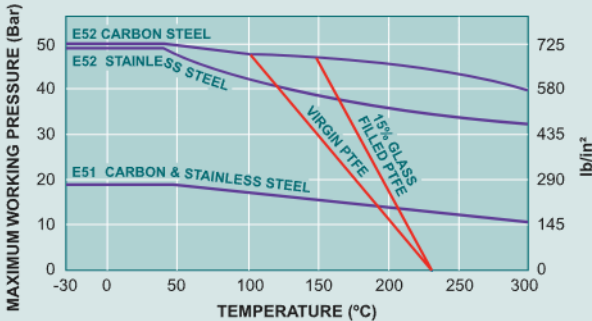

Fluorofill

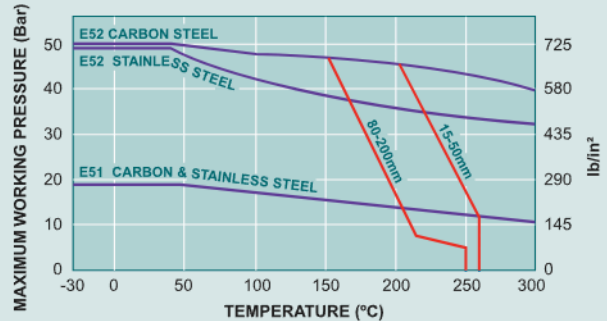

PEEK

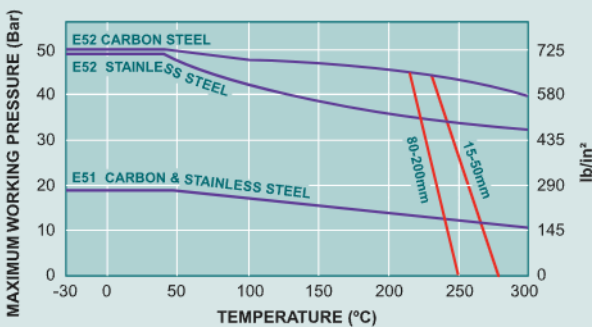

Metal (G)

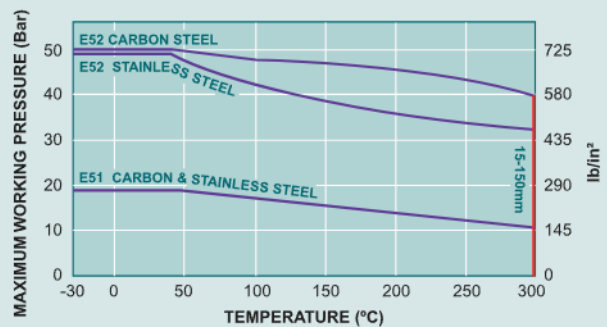

Notes

1. For firesafe valves, square section expanded graphite packings are used.
2. When wrench not fitted, flats on stem when parallel to pipeline axis, denotes ball open position.
3. Other seat variations are available.
4. Installation, Operating and Maintenance instructions are supplied with product and are also available on request.

Standards of Compliance

Flange Dimensions	BS EN 1759-1 Class 150/300, BS EN 1092, PN16/40
Pressure Test Certification	BS EN 12266-1 Part 1
Face to Face Dimensions	ASME B16.10, BS EN 558-2 Table 6
Quality Assurance	ISO 9001, ISO 17025 (optional)

Flow Coefficients & Weight

Valve Size (mm)	Flow Coefficients		Weight (kg)	
	(Cv)	(Kv)	150	300
15	7	6	3	3.5
20	10	8.7	3	4.3
25	30	26	4.5	6.4
40	89	77	7.6	11.3
50	130	112.5	10.3	12.9
80	350	303	19.0	26.7
100	720	623	28.8	40.7
150	1020	882	52.0	77.6
200	1800	1557	82.5	120.5

Cv – Flow in US GPM Pressure – psi
Kv – Flow in M³/hr Pressure – bar

FCD WCEBR0012-01 Printed in Germany. (Replaces PB06 Rev 11/02)

To find your local Flowserve representative:

For more information about Flowserve Corporation, visit www.flowserve.com or call USA 1 800 225 6989



Flowserve Flow Control

A Division of Flowserve GB Ltd
Burrell Road, Haywards Heath
West Sussex RH16 1TL
United Kingdom
Telephone: +44 (0)1444 314400
Telefax: +44 (0)1444 314401
Email: wwukinfo@flowserve.com

Due to continuous development of our product range, we reserve the right to alter the dimensions and information contained in this leaflet as required. Information given in this leaflet is made in good faith and based upon specific testing but does not, however, constitute a guarantee.