



ISO Registered Company



MODEL SAP

ULTRA HIGH PURITY PRESSURE REDUCING REGULATOR

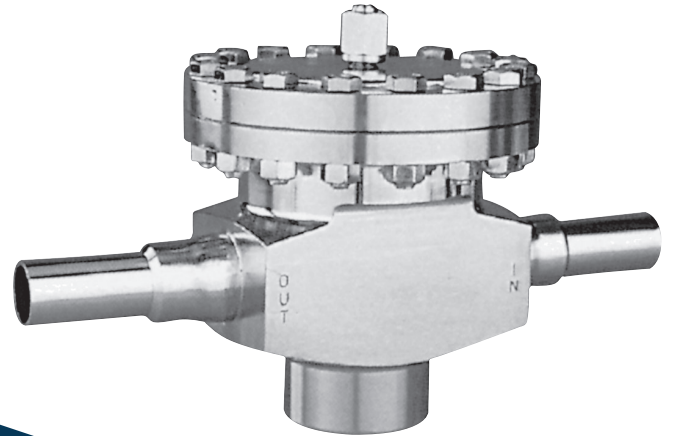

MODEL SAP

OVERVIEW

Model SAP is a high performance, dome loaded, piston-style, flow-to-open pressure reducing regulator with internal pressure balancing piston-cylinder that provides medium flow capacity and high pressure drop capability.

FEATURES

- All SST wetted trim materials.
- Electro-polished.
- Tube-end connections.
- High pressure capability.
- Body Finish - Internal Surface Only
Barstock Body - 10 μ -in R_a average surface finish.
- In-line maintenance.

APPLICATIONS

For “electronic grade” and other ultra high purity fluids. For gaseous service. Most common fluids are high purity oxygen, nitrogen, hydrogen, helium and argon.



LINE SIZES AVAILABLE

3/4" (DN20) 1" (DN25), 2" (DN50),
3" (DN80), 4" (DN100)



END CONNECTIONS

TUBE-ENDS FOR BUTT WELDING
USING ORBITAL WELDER



COMMON APPLICATIONS

GASEOUS SERVICE, HIGH PURITY
OXYGEN, NITROGEN, HELIUM, ARGON



DESIGN PRESSURE

INLET: UP TO 3000 psig (207 Barg)
OUTLET: 5-600 psig (0.34-41.4 Barg)

TECHNICAL SPECIFICATIONS

BODY SIZES

3/4", 1", 2", 3", 4"
(DN20, 25, 50, 80, 100)

MAXIMUM INLET PRESSURE

Up to 3000 psig (207 Barg)
Function of body size and elastomeric internal materials. See Table 1 for Design Pressure vs. Temperature Ratings, and maximum operating pressures. (Internals can withstand a full vacuum.)

FLOW CAPACITY

Body Size		Max Useable Cv
in	(DN)	
3/4"	(20)	5
1"	(25)	6
2"	(50)	48
3"	(80)	90
4"	(100)	120

OUTLET PRESSURE RANGE

5 – 600 psig (.34 – 41.4 Barg)
Maximum available controlled pressure a function of body size.

TEMPERATURE RANGE

-20 to +400° F (-29° to +204° C)
Function of elastomeric internal materials. See Table 1.

AGGREGATE INTERNAL LEAKAGE

Combination of dynamic seal and seat leakage rates:
0.000 1% of rated Cv.

HELIUM LEAK TEST

Inboard leakage less than 1×10^{-9} std cc/sec, actual test.

END CONNECTIONS

Tube-ends for butt welding using orbital welder.
Wall thickness = 0.065 in. (1.65 mm) for 3/4" - 3" sizes.
Wall thickness = 0.083 in. (2.11 mm) for 4" size.
Nominal body size = Tube OD.

MATERIAL SPECIFICATIONS

BODY FORM

Barstock: All sizes.

BODY MATERIALS - SST

Barstock: ASTM A479, Tp. 316L.

Loading Chamber fabricated from materials of 316L SST.

INTERNAL TRIM & MISC MATERIALS

- Trim - 316L SST
- Static Seals - FKM Elastomer O-ring
- Dynamic Seal - Type "UC": TFE/SST
- Seat - PolyAll (GN2, He, Ar, H2)
V-TFE (GOX)
CTFE (All above fluids)
- Lower Piston Spring - 17-7PH SST
- Cap Screws - Ag-plated SST
- Flange Bolting - SST
- Body/
- Cover Dome Seal - FFKM - Perfluoroelastomer O-Ring

SURFACE FINISH

Metallic parts are electro-polished, passivated, and cleaned to Cashco cleaning specification #S-1662.

Surface Finish - μ-in.		
Barstock	Metal Trim Parts	10 R _a Avg

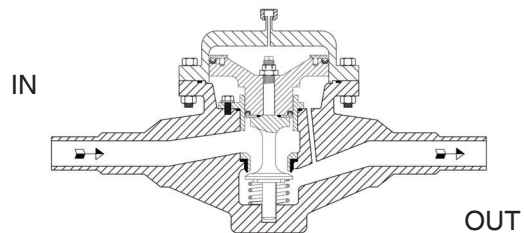

**TABLE 1
MAXIMUM DESIGN PRESSURE vs. TEMPERATURE:
MAXIMUM OPERATING PRESSURES, TEMPERATURES
AND PRESSURE DROPS**

NOTE: The below ratings may be further "derated" by limitations through the Pressure Equipment Directive (2014/68/EU)

Nominal Body Size in (DN)	Design Pressure**		Temperature Range	Seat Material	Maximum Operating Pressures		
	Inlet psig	Outlet psig	°F		Inlet psig	Outlet psig	ΔP psig
3/4" (20)	3000	600	-20 to + 225	PolyAll	1050	600	750
	3000	600	-20 to + 300	V-TFE	900	600	600
	2895	600	400			600	
	3000	600	-20 to + 300	CTFE	3000	600	2950
1" (25)	2400	600	-20 to + 225	PolyAll	1050	600	750
	2400	600	-20 to + 300	V-TFE	900	600	600
	2230	600	400			600	
	2400	600	-20 to + 300	CTFE	2400	600	2350
2" (50)	1200	600	-20 to + 225	PolyAll	1050	600	750
	1200	600	-20 to + 300	V-TFE	900	600	600
	1155	600	400			600	
	1200	600	-20 to + 300	CTFE	1200	600	1150
3" (80)	600	600	-20 to + 225	PolyAll	600	600	300
	600	600	-20 to + 300	V-TFE		600	
	450	450	400		450	600	150
	600	600	-20 to + 300	CTFE	600	600	300
4" (100)	600	600	-20 to + 225	PolyAll	600	300	600
	600	600	-20 to + 300	V-TFE		450	
	450	450	400		450	300	600
	600	600	-20 to + 300	CTFE	600	300	600

** For fluid containment only - Reaching these levels of pressure will damage internals and may render unit inoperable.

METRIC CONVERSION FACTOR: psi / 14.5 = Bar Cv / 1.16 = kv

DIMENSIONS & WEIGHTS

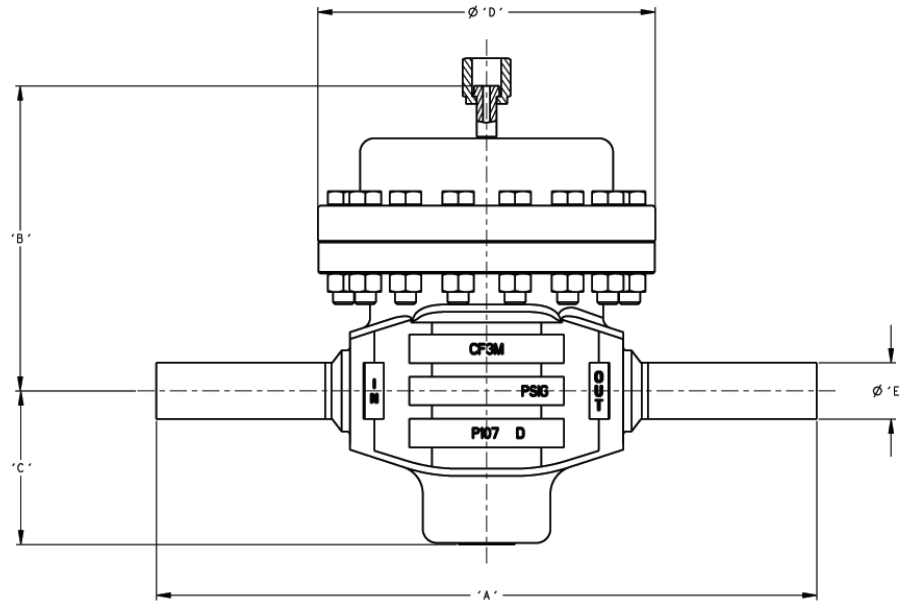

SIZE	ENGLISH UNITS (Inches)					Weight lbs
	A	B	C	Dia. D	Dia. E	
3/4"	10.75	5.44	2.75	6.00	0.75	25
1"	11.75	5.44	2.75	6.00	1.00	25
2"	15.75	8.00	4.49	8.00	2.00	75

SIZE	METRIC UNITS (mm)					Weight kg
	A	B	C	Dia. D	Dia. E	
DN20	273	138	70	152	19	12
DN25	298	138	70	152	25	12
DN50	400	203	114	203	51	35

DIMENSIONS

3" & 4" Sizes

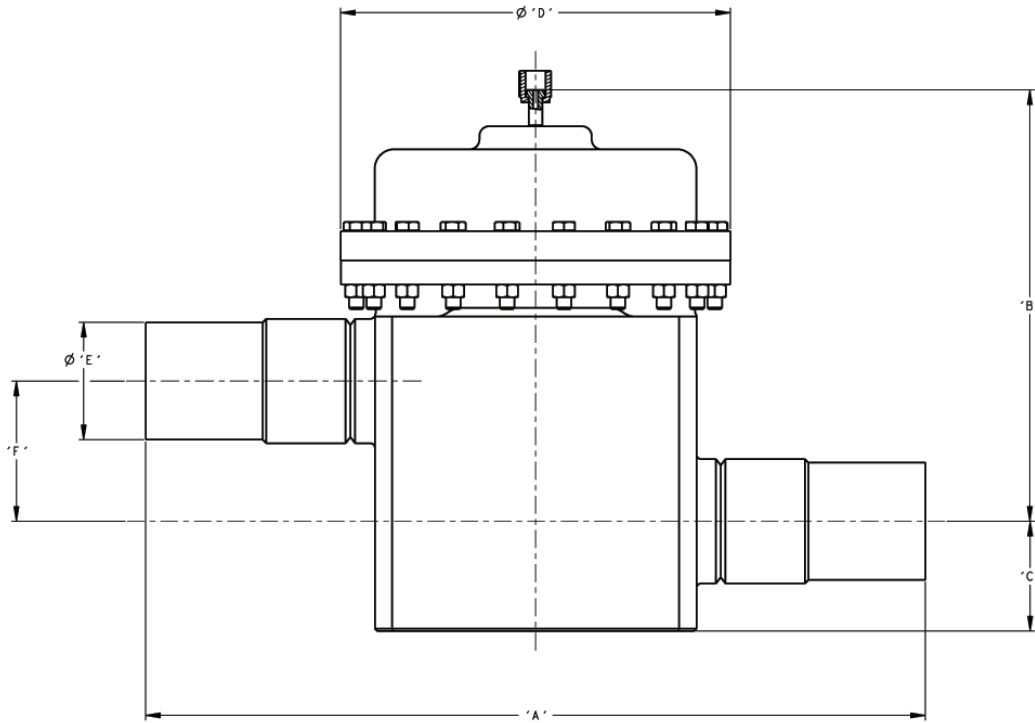

ENGLISH UNITS (in)							Wt. lbs.
SIZE	A	B	C	Dia. D	Dia. E	Dia. F	
3"	20.00	11.06	2.81	10.00	3.00	3.60	150
4"	20.00	11.06	2.81	10.00	4.00	3.60	150

METRIC UNITS (mm)							Wt. kgs.
SIZE	A	B	C	Dia. D	Dia. E	Dia. F	
DN80	508	281	71	254	76	91	69
DN100	508	281	71	254	102	91	69

The contents of this publication are presented for informational purposes only, and while every effort has been made to ensure their accuracy, they are not to be construed as warranties or guarantees, express or implied, regarding the products or services described herein or their use or applicability. We reserve the right to modify or improve the designs or specifications of such product at any time without notice.

Cashco, Inc. does not assume responsibility for the selection, use or maintenance of any product. Responsibility for proper selection, use and maintenance of any Cashco, Inc. product remains solely with the purchaser.

MODEL SAP PRODUCT CODER 02/07/20

S**P** POS 3 - **S****L** POS 7 **7** - **T****0****3****0****0****0****0****0****0****D**

POSITION 3 - SIZE		
Size		CODE
in	(DN)	
3/4"	20	B
1"	25	C
2"	50	F
3"	80	H
4"	100	R

POSITION 7 - SEAT / SEALS / GASKETS				
Seat	Static	Dynamic	Body/Cover Dome Seal	CODE
V-TFE	FKM	U-Cup TFE/SST	FFKM	R
POLYALL	FKM	U-Cup TFE/SST	FFKM	T
CTFE	FKM	U-Cup TFE/SST	FFKM	Z

*** For information on ATEX see pages 11 & 12 on the IOM.**

Cashco, Inc.
P.O. Box 6
Ellsworth, KS 67439-0006
PH (785) 472-4461
Fax. # (785) 472-3539
www.cashco.com
email: sales@cashco.com
Printed in U.S.A. SAP-TB

Cashco GmbH
Handwerkerstrasse 15
15366 Hoppegarten, Germany
PH +49 3342 30968 0
Fax. No. +49 3342 30968 29
www.cashco.com
email: germany@cashco.com

Cashco do Brasil, Ltda.
Al.Venus, 340
Indaiatuba - Sao Paulo, Brazil
PH +55 11 99677 7177
Fax. No.
www.cashco.com
email: brazil@cashco.com