



ISO Registered Company

MODEL P4

BALANCED PRESSURE REDUCING REGULATOR

OVERVIEW

The Model P4 is designed for gases with inlet pressures up to 3600 psig (248 Barg). Standard adjustable outlet ranges from 1-10 psig (.07-.69 Barg) thru 10-500 psig (.69-34.5 Barg). Flow coefficient of .6 Cv available. This versatile point of use regulator can be ordered with a variety of options to meet your system demands.

FEATURES

- Accurate Adjustment
- Balanced Trim
- Low Internal Volume
- Low Operating Torque
- Suitable for Corrosive applications
- Suitable for High Purity Gas applications

FUNCTIONAL PERFORMANCE

Supply Pressure	
Effect:	2/100 psig (.14/6.9 Barg)
Temperature	
Coefficient:	0.16 psig/°F (.01 Barg/ °C)
Design Proof Pressure	150% of Max Operating Pressure
Pressure:	5,400 psig (372.3 Barg)
Internal Volume:	10 cc
Design Leakage:	
Outboard	1x10 ⁻⁹ scc/sec He
Inboard	1x10 ⁻⁹ scc/sec He
Cv Capability:	.6



MODEL P4



LINE SIZES AVAILABLE

3/8" (DN10), 1/2" (DN15)



END CONNECTIONS

FNPT, TUBE ENDS, TRI-CLAMP



COMMON APPLICATIONS

CORROSIVE, HIGH PURITY GAS



DESIGN PRESSURE

INLET: UP TO 3600 psig (248 Barg)
OUTLET: 1-500 psig (0.07-34.5 Barg)

GENERAL SPECIFICATIONS

Inlet / Outlet Size:	3/8" & 1/2" (DN10 & DN15)	Wetted Material: Temp. Limits:	See Position 6 Kel-F - TFE - Buna-N -
Maximum Inlet Pressure:	FNPT/Tube Ends - 3,600 psig (248 Barg) Tri-Clamp - 300 psig (20.7 Barg)	Operating Temp. Range:	-45 to 185°F (-42.7 to 85°C) -45 to 275°F (-42.7 to 135°C) -55 to 225°F (-48.2 to 107°C)
Outlet Pressure:	1-500 psig (.07-34.5 Barg)	Range Spring Material:	-20 to 275°F (-28.9 to 135°C) Std: Steel, Sanitary Service: SST 1-250 psig
Body End Connections:	FNPT - 3/8" & 1/2" (1/2" O.D. Max Press. 2,780 psig.) (191.7 Barg) Tri-Clamp - 1/2" Size Only Tube End - 1/2" Size Only	Composite Knob: (Standard)	-50 to 200°F (-45.6 to 93°C) For temperatures outside (Std.) knob range see Options for Colored Knobs.
Body and Spring Chamber Material:	316L SST/316L SST Brass/6061 AL <u>Sanitary Construction:</u> Interior of body surface Electro Polished to 16 micro-inch Ra finish with Electro Polished exterior.		

STANDARD CONSTRUCTION

Captured Vent

The captured vent feature is designed to safely vent process fluid when handling toxic or hazardous media. The user can easily pipe this vent to a safe location. It features a 1/8" FNPT port located on the spring housing. This feature can be incorporated into a self-relieving regulator that provides an additional port to permit the piping away of the expelled media.

OPTIONS

NACE Construction - (P or R) in Position 6. - Internal wetted portions meet NACE standard MR0175, when the exterior of the regulator is not directly exposed to a sour gas environment, buried, insulated or otherwise denied direct atmospheric exposure. SST/SST body/spring chamber materials only. Inconel w/TFE liner, Buna-N o-ring/TFE Back up ring, Inconel X-750 spring.

Panel Mount - (C) in Position 14. - The panel mount feature requires a panel minimum of 11 gauge (.12) thick with a 1-3/8" hole cut out, complete with a threaded spring housing, and a panel mount ring to secure the regulator.

Tamper Proof - (1) in Position 15. - In this feature the control knob is removed and replaced with an acorn nut. The user can set the outlet pressure and securely tighten the nut, preventing any unwanted adjustments on the regulator.

Colored Knobs - (2, 8 and W) in Position 15. - In this feature the control knob is anodized aluminum either in black, blue, green or red, compared to the standard red composite knob. This allows for color coding of processes. Temperature range: -55 to 300°F (-45.6 to 149 °C).

Relief Valve - (H, J, K, or L) in Position 16. - The relief valve main function is to relieve excess downstream pressure due to system malfunctions. This feature prevents over pressurization by automatically venting of gas or liquid. The valve is fully adjustable and is 1/4" male x 1/4" male.

Cleaned for Oxygen Service #S-1134 - (M) in Position 17. - This is a requirement for gaseous oxygen environments. All regulators requiring advanced cleaning shall be processed according to strict guidelines. **NOTE:** Design Pressure Rating shall not exceed 375 psig (25.8 Barg) when body material is SST and process medium is oxygen.

Cleaned per Spec. #S-1542 - (N) in Position 17. - Cleaning identical to that of #S-1134, but not labeled for application in oxygen service. NOT suitable for Oxygen Service.

Sanitary Construction - (P) in Position 17. - SST Construction with Smooth SST Knob - Interior of body surface Electro Polished to 16 micro-inch Ra finish with Electro Polished exterior. Tri-Clamp Ends 1/2" Size only. Unit is cleaned to Cashco Spec. #S-1576. Comply with FDA 21 CFR 177 2600 & USP Class VI material classification.

DIMENSIONS

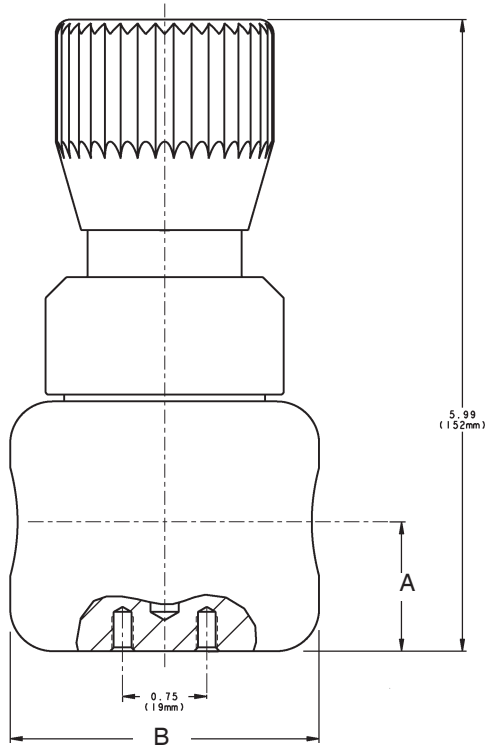

English Units In. & lbs.			
Size A	A	B	Wt
3/8" & 1/2" NPT	1.15	2.75	2.2
1/2" Tube	1.25	6.94	2.4
1/2" Tri-Clamp	1.25	4.88	2.4
Metric Units mm & kg			
DN10, DN15 NPT	28	70	1.0
DN15 Tube	32	177	1.0
DN15 Tri-Clamp	32	124	1.0

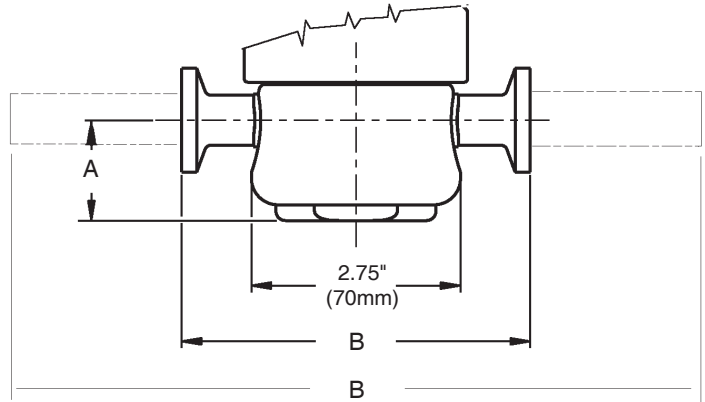

Porting Configuration Guide

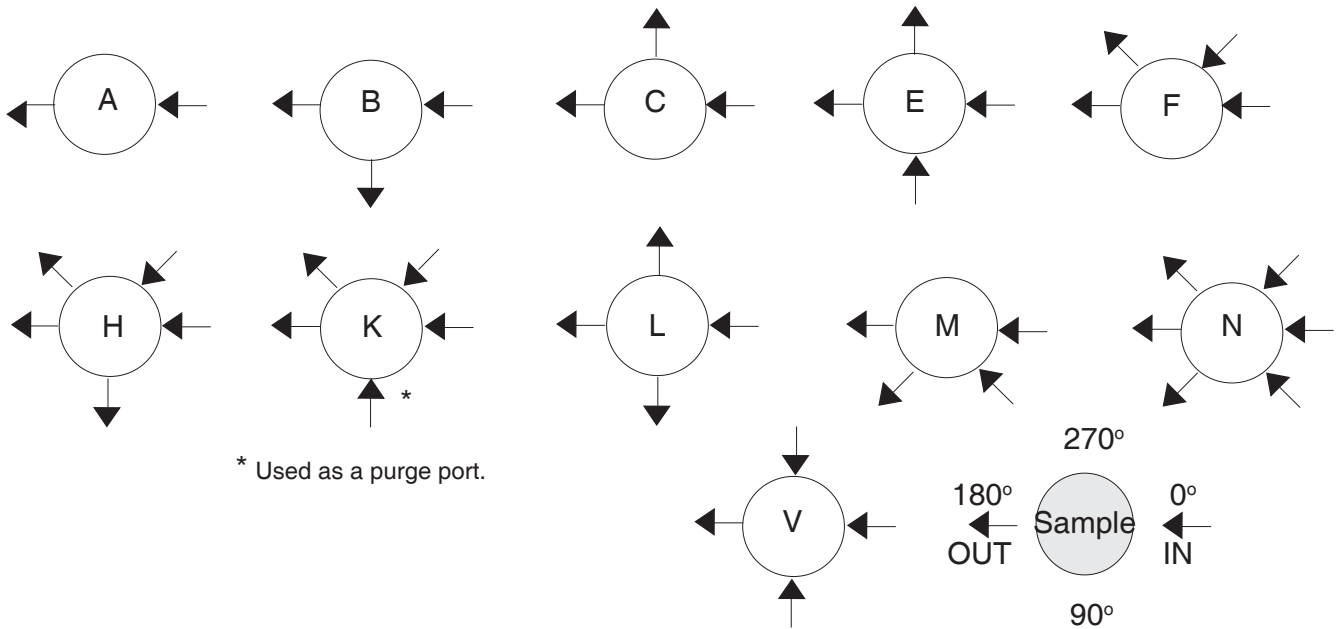

The contents of this publication are presented for informational purposes only, and while every effort has been made to ensure their accuracy, they are not to be construed as warranties or guarantees, express or implied, regarding the products or services described herein or their use or applicability. We reserve the right to modify or improve the designs or specifications of such product at any time without notice. Cashco, Inc. does not assume responsibility for the selection, use or maintenance of any product. Responsibility for proper selection, use and maintenance of any Cashco, Inc. product remains solely with the purchaser.

MODEL P4 PRODUCT CODER 02/07/20

(COMPOSITE RED KNOB STANDARD)

An "X" in POS 12 followed by a 5-digit control number overrides remaining selections.

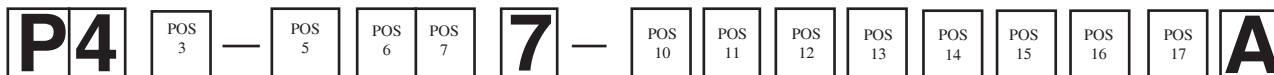

POSITION 3 - BODY SIZE/Cv		
Size	Cv	CODE
3/8" (DN10)	0.60	B
1/2" (DN15)	0.60	A

POSITION 5 - BODY & SPRING CHAMBER MATERIAL	
Body / Spring Chamber	CODE
Brass / 6061 AL	B
316L SST / 316L SST *	S

* Select for NACE or Sanitary Construction

POSITION 6 - TRIM MATERIALS		
Diaphragm , Seat Retainer, Poppet & Poppet Spring	Seat Material	CODE
302 SST w/Tefzel ring, 316L SST, 316L SST, Inconel X-750, FKM/TFE Back-up	PCTFE	G
	TFE	U
Inconel w/TFE liner, Monel R-405, Monel R-405 Inconel X-750 FKM/TFE Back-up	PCTFE	V
	TFE	X
NACE - Inconel w/TFE liner, 316L SST, 316L SST, Inconel X-750 Buna-N/TFE Back-up	PCTFE	P
	TFE	R
For Sanitary / Pharmaceutical Construction *		
302 SST w/TFE liner, 316L SST, 316L SST, Inconel X-750 FKM/TFE Back-up	TFE	Q **
	TFE	S

* 16 Micro-inch Ra Finish w/Electro-Polish, Range 1-250psig. Only available for Port "A". Select code "P" in Position 17.
** Comply with FDA 21 CFR 177.2600 & USP Class VI material classification.

POSITION 7 - PORTING CONFIGURATION			
Description	CODE	Description	CODE
See Porting Guide	**** A	See Porting Guide	*** N
	** B		*** K
	** C		** L
	*** E		*** M
	*** F		*** V
	*** H		

NOTE: When selecting from Positions 12 & 13, review following and select appropriate configuration code from above.

- * Inlet gauge port only
- ** Outlet gauge port only
- *** Inlet & outlet gauge ports
- **** No gauge ports available

POSITION 10 - END CONNECTIONS	
End Connection(s)	CODE
FNPT ***	1
Tri-Clamp *	S
Tube End *	T
1/2" MNPT x 1/2" Compression End	6
1/2" MNPT x 3/4" Compression End	7
Reducing Adaptor (1/2" MNPT x 3/4" FNPT) **	Q
Reducing Adaptor (1/2" MNPT x 1" FNPT) **	R

* Not Available with Brass body or 3/8" size.
** ONLY for primary inlet & outlet ports.
*** Not available for Sanitary Construction - Clean per #S-1576

POSITION 11 - RANGE SPRING/OUTLET PRESSURE	
Psig (Barg)	CODE
1 - 10 (.07 - .69)	1
2 - 25 (.14 - 1.7)	2
2 - 50 (.14 - 3.4)	3
2 - 100 (.14 - 6.9)	4
3 - 250 (.21 - 17.2)	5
5 - 500 (.34 - 34.5) *	6

* Not Available 1/2" Size - Tri Clamp End Connections

POSITION 12 - OUTLET GAUGE (See "NOTE" - Position 7)	
Psig (Barg)	CODE
0 - 15 (0 - 1.0)	A
0 - 30 (0 - 2.1)	B
0 - 60 (0 - 4.1)	C
0 - 100 (0 - 6.9)	D
0 - 160 (0 - 11.0)	E
0 - 300 (0 - 20.7)	F
0 - 600 (0 - 41.4)	G
No Outlet Gauge	0
For Special Construction Contact Cashco for Special Product Code	X

POSITION 13 - INLET GAUGE (See "NOTE" - Position 7)	
Psig (Barg)	CODE
0 - 15 (0 - 1.0)	A
0 - 30 (0 - 2.1)	B
0 - 60 (0 - 4.1)	C
0 - 100 (0 - 6.9)	D
0 - 160 (0 - 11.0)	E
0 - 300 (0 - 20.7)	F
0 - 600 (0 - 41.4)	G
0 - 1000 (0 - 69.0)	H
0 - 2000 (0 - 137.9)	I
0 - 3000 (0 - 206.9)	J
0 - 5000 (0 - 344.9)	K
No Inlet Gauge	0

POSITION 14 - OPTIONS			
OPTIONS	CODE	OPTIONS	CODE
No Option	0	Panel Mount.	C
Mounting Bracket.	5		

POSITION 15 - OPTIONS			
OPTIONS	CODE	OPTIONS	CODE
No Option	0	Blue Knob.	8
Tamper Proof.	1	Red Knob.	W
Black Knob.	2		

POSITION 16 - OPTIONS			
OPTIONS	CODE	OPTIONS	CODE
No Option	0	Relief Valve: 150-350 psig. *	K
Relief Valve: 3-50 psig. *	H	Relief Valve: 350-600 psig. *	L
Relief Valve: 50-150 psig.*	J		

* When selecting Relief Valve indicate SET POINT PRESSURE in Special Instructions on order. If outlet gauge is also specified, Body Port Configuration must have two outlet ports. See Porting Guide page 3.

OPTION 17 - OPTIONS			
OPTIONS	CODE	OPTIONS	CODE
No Option	0	Oxygen Cleaned Per Spec #S-1134.	M
		* Special Cleaning: Per Spec #S-1542.	N
		Sanitary Construction - Clean per #S-1576	P

* NOT suitable for Oxygen Service.

*** For information on ATEX see pages 8 & 9 on the IOM.**

Cashco, Inc.
P.O. Box 6
Ellsworth, KS 67439-0006
PH (785) 472-4461
Fax. # (785) 472-3539
www.cashco.com
Email: sales@cashco.com
Printed in U.S.A. P4-TB

Cashco GmbH
Handwerkerstrasse 15
15366 Hoppegarten, Germany
PH +49 3342 30968 0
Fax. No. +49 3342 30968 29
www.cashco.com
email: germany@cashco.com

Cashco do Brasil, Ltda.
Al.Venus, 340
Indaiatuba - Sao Paulo, Brazil
PH +55 11 99677 7177
Fax. No.
www.cashco.com
email: brazil@cashco.com