

IMI PBM ANGLE STEM TANK BOTTOM VALVES

AF Series 1, 1" - 6"



DESIGN FEATURES:

- Unique Adjust-O-Seal® feature allows in-line valve adjustment to compensate for normal wear on valve seats.
- **AF Series Tank Bottom valves DO NOT have o-rings.**
- Designed for applications where automation may interfere with tank head or jacket.
- Pad radius facilitates efficient drainage and reduces the pocket area above the ball.
- Stem assembly accommodates IMI PBM Direct Mount Actuation for accurate alignment and increased cycling life.
- Valves are rated for full vacuum.
- Certified Material Test Report (CMTRS) provided for weld pads and sanitary wetted components
- Surface finishes are achieved without the use of ADIs (Animal Derived Ingredients)

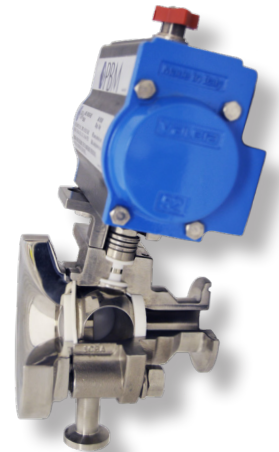

SPECIFICATIONS	Angle Stem Valves
Sizes	1" - 6" depending on series (8" AF valve available - consult factory)
Material	316L, 316L SS, Hastelloy™, AL6XN™, others
End Connections	Hygienic clamp, FNPT, 150# RF flange, others
Seats & Seals	VTFE (Sanitary), RTFE (Industrial), others
Stem Packing Material	VTFE and RTFE
Body Bolts & Nuts	18-8 Stainless Steel
Maximum Working Pressure	up to 900 psig CWP depending on valve series, size and temperature
Temperatures	up to 450°F depending on seat and seal material
Polish	Standard internal polish of 125 Ra ID

CV Values (gpm), AF Series 1		
Size	End Connection	
	X-	Q, L
1"	63	65
1-1/2"	150	143
2"	280	280
3"	505	700
4"	690	880
6"	1,430	1,500

Why an Angle Stem (AF) Flush Tank ball valve?

The IMI PBM Angle Stem Flush Tank valve provides actuator clearance on jacketed or insulated vessels. On the 1" and the 1-1/2" AF valves, the stem is at a 10° offset from that of a straight stem Flush Tank (FT) ball valve and 15° for the 2", 3", 4" and 6" AF valves.

How To Order:

PRODUCT (1-2) MATERIAL (3-4)		SIZE (5) SERIES (6)			END CONNECTIONS (7-8)		SEAT & SEAL (9)		WELD PAD (10-11)		BALL & STEM (12)	OPERATOR (13-14)		POLISH (15-16)			
PRODUCT (1-2) MATERIAL (3-4)	SIZE (5) SERIES (6)	END CONNECTION (7-8)		SEAT / SEAL (9)		FLUSH TANK PAD OPTIONS (10-11)		BALL / STEM OPTIONS (12)		OPERATOR (13- 14)		POLISH OPTIONS (15)					
AF	H-	Cast 316/316L S / S	E	1"	1	X-	Hygienic Clamp	A	RTFE Seats / Seals	--	Standard Weld Pad	-	Standard Ball and Stem	--	W/ Standard Lever Handle	-	125 Ra ID
	HL	Cast 316L S / S	G	1-1/2"		Q-	FNPT	B	RTFE Seats / Seals VTFE Cavity Fillers	02	w/o weld pad w/ shipping pad	F	Internal / External Grounding	02	W/O Handle W/ Stem Actuator Prep	A	20 Ra ID
	C-	Hastelloy C-276	H	2"		L-	150# RF Flange	C	VTFE Seats / Seals			G	17-4PH Stem	04	Locking Lever Handle	D	15 Ra ID
	Y-	Hastelloy C-22	L	4"		* Only available in Sanitary Clamp and RF Flange VTFE seats & seals Std for "X" RTFE seats & seals Std for "Q" and "L"		D	VTFE Seats / Seals VTFE Cavity Fillers	Other Weld Pad Options available - Contact PBM				08	Gear Operator (Req'd for 6")	E	10 Ra ID
	P-	AL6XN	M*	6"				H	S-TEF® Seats / Seals					27	DA 80psig actuator	F	20 Ra ID after Electro Polish
			N**	8"		I	S-TEF® Seats / Seals VTFE Cavity Fillers			34	SR 80psig actuator	G	15 Ra ID after Electro Polish				
										41	SR 60psig actuator	H	10 Ra ID after Electro Polish				

Other material options available - Contact PBM.

Other operator options available - Contact PBM.

Other seat/seal options available - Contact PBM.

More polish available - Contact PBM.

<http://pbmvalve.com/build-a-part-number>

IMI PBM Angle Stem Tank Bottom Valve, Series 1, Manual

Angle Stem Flush Tank Valve, FNPT End

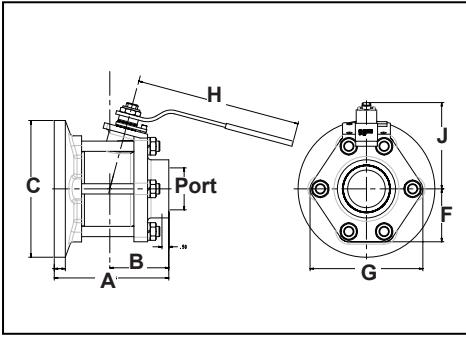

Angle Stem Flush Tank Valve, Flanged End

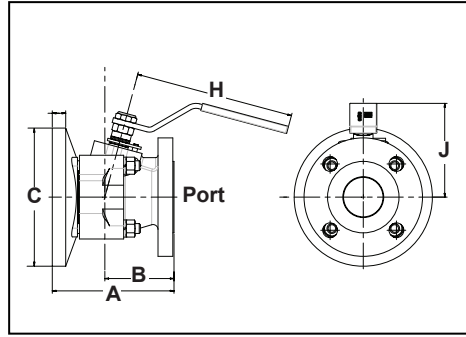

Angle Stem Flush Tank Valve with Gear Operator

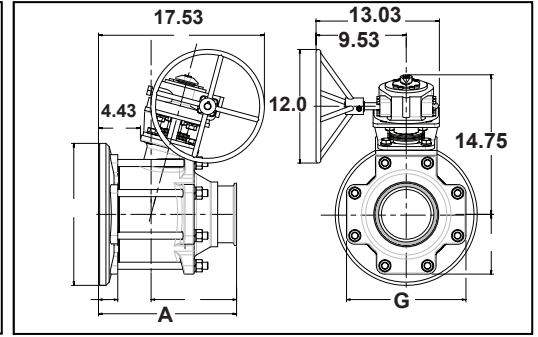

Angle Stem Tank Bottom Valve Dimensioned valves in inches

Valve Size	Size Code	I.D. Port	Face to Face A			C to End B			Pad Dia. C	Pad Width D	C to Bottom		Handle Length H	C to Top J	Approx. Wgt. (lbs.)		
			X	Q	L	X	Q	L			F	G			X	Q	L
1"	E	1.00	3.88	3.58	4.14	2.24	1.94	2.50	3.70	0.53	1.69	3.38	6.09	3.07	5.83	6.84	7.74
1-1/2"	G	1.50	4.71	4.97	5.53	2.43	2.69	3.25	5.50	0.62	1.78	3.44	8.06	4.48	12.25	12.88	16.26
2"	H	1.94	5.51	5.64	6.18	2.84	2.96	3.50	7.00	0.68	2.12	4.24	8.06	4.38	19.64	19.94	25.41
3"	K	2.75	7.88	8.38	9.19	3.81	4.31	5.12	10.00	0.79	3.87	8.25	12.06	6.31	62.60	63.50	74.81
4"	L	3.50	8.94	9.52	10.48	4.66	5.24	6.20	11.50	0.91	4.47	8.94	12.06	6.78	89.24	90.50	106.61
6**	M	5.24	14.59	NA	15.61	9.03	NA	10.05	15.00	1.04	6.31	12.62	NA	11.89	450.39	NA	474.11

* Only available in Sanitary Clamp and RF Flange
8" AF valve available - consult factory

ID Surface Finish, Ra Readings for Valves per ASME BPE			
Surface Finish	IMI PBM Polish Code	μ-in.	μ-m.
Mechanical Polish			
SF 1	A	20 Ra max	0.51
SF 2	A	25 Ra max	0.64
SF 3	-	30 Ra max	0.76
Mechanical Polish and Electropolish			
SF 4	G	15 Ra max	0.38
SF 5	F	20 Ra max	0.51
SF 6	F	25 Ra max	0.64

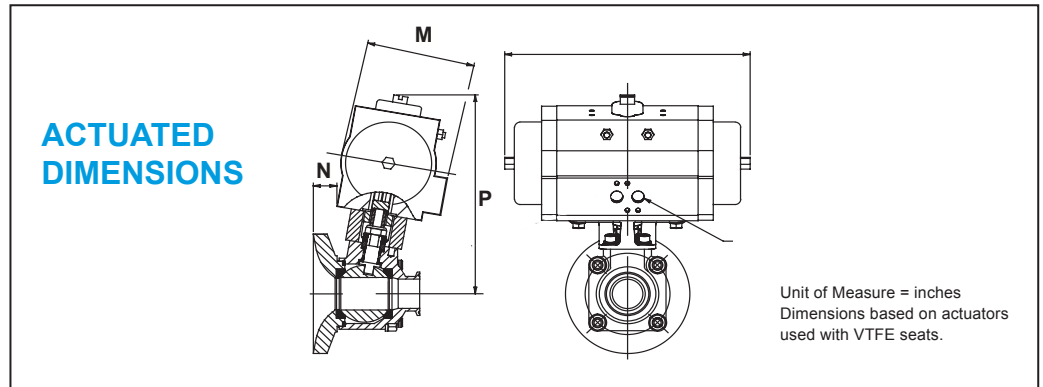

Size	80, 60 PSI Double Acting					80 PSI Spring Return					60 PSI Spring Return				
	L	M	N	P	R	L	M	N	P	R	L	M	N	P	R
1"	5.55	2.79	0.85	6.67	1/8 NPT	8.27	3.72	0.73	7.86	1/8 NPT	8.27	3.72	.73	7.86	1/8 NPT
1-1/2"	8.27	3.72	1.55	8.90	1/8 NPT	9.48	4.17	1.37	9.45	1/8 NPT	10.83	4.85	1.10	9.96	1/4 NPT
2"	8.27	3.72	2.49	8.97	1/8 NPT	10.83	4.85	2.07	10.01	1/4 NPT	13.12	5.39	1.86	11.32	1/4 NPT
3"	13.12	5.39	3.32	13.80	1/4 NPT	14.65	5.83	3.32	14.35	1/4 NPT	16.85	6.45	3.32	15.20	1/4 NPT
4"	13.12	5.39	3.66	14.41	1/4 NPT	16.85	6.45	3.66	15.58	1/4 NPT	16.85	6.45	3.66	15.58	1/4 NPT
6"	16.85	6.45	4.88	19.24	1/4 NPT	22.78	8.54	4.66	22.41	1/4 NPT	26.46	11.42	4.37	26.98	1/4 NPT