



I Application

Hygiene is an essential part of the processes of the food processing, cosmetics, pharmaceutical industries as a correct cleaning of all the elements is required (tanks, pipes, pumps, etc.). We offer automated CIP units, correctly selected and customized to guarantee a controlled cleaning and efficiency without having to disassemble the plant.

I Design and features

PORTABLE CIP DESIGN

It consists of the following elements:

- Two AISI 316 tanks, jacketed, of 250L for the preparation of cleaning solutions. Conical bottoms.
- Electric heaters inside the tank.
- Peristaltic, piston or membrane pumps for dosing of concentrates.
- 4kW Hyginox SE impulsion pump.
- AISI 316 collectors with pneumatic butterfly valves with C-TOP units.
- AISI 304 frame with wheels.
- Return filter.
- Temperature control inside the tanks and conductivity control in the return line.
- Level control in the tanks.
- Flow control in the return line.
- Pressure gauge at the pump impulsion.
- 6" touch screen.
- PLC Siemens system control.
- 5 programmes: preparation, short tank cleaning, short line cleaning, tank long cleaning and long line cleaning. Manual valve activation. Plant state displaying. Change of parameters.
- Tested and verified in our test house.



I Design and features

ONE LINE STATIC CIP UNIT DESIGN

It consists of the following elements:

- Two AISI 316 tanks, jacketed, of 1000L for the preparation of cleaning solutions. Conical bottoms.
- One AISI 304 tank, not jacketed, of 1500L for recovered water. Conical bottoms.
- Heating by a steam heat exchanger, with a graduated acting steam valve, drains...
- Peristaltic, piston and membrane pumps for concentrates dosing.
- 5.5kW Hyginox SE impulsion pump.
- AISI 316 collectors with pneumatic butterfly valves with C-TOP.
- AISI 304 frame with adjustable legs.
- Filter in return line.
- Temperature control inside the tanks and conductivity control in the return line.
- Level control in the tanks.
- Flow control in the return line.
- Pressure gauge at the pump impulsion.
- 10" touch screen.
- PLC Siemens system control.
- 5 programmes: preparation, short tank cleaning, short line cleaning, tank long cleaning and long line cleaning. Manual valve activation. Plant state displaying. Change of parameters.
- Tested and verified in our test house.



I Options

- Recirculation inside the tanks by means of a pump.
- Additional tank for sterilant alternatively inline dosing.
- Handshakes between the CIP control panel and other control systems on the plant.
- Valves without feed back.
- Use of double seat or single seat valves instead of the butterfly valves.
- Tubular heat exchanger.
- Other tank configurations (2 simultaneous lines, bigger volumes...).
- Flow control.
- Logging of the operating data.
- Fixed plant due to size.

I Materials

Parts in contact with the media	AISI 316L
Other parts	AISI 304
Insulation	rock wool
Gaskets (valves, pumps, connections)	EPDM



FTCIP.1.EN-0606

1 Standard CIP unit general dimensions

One line mobile CIP unit

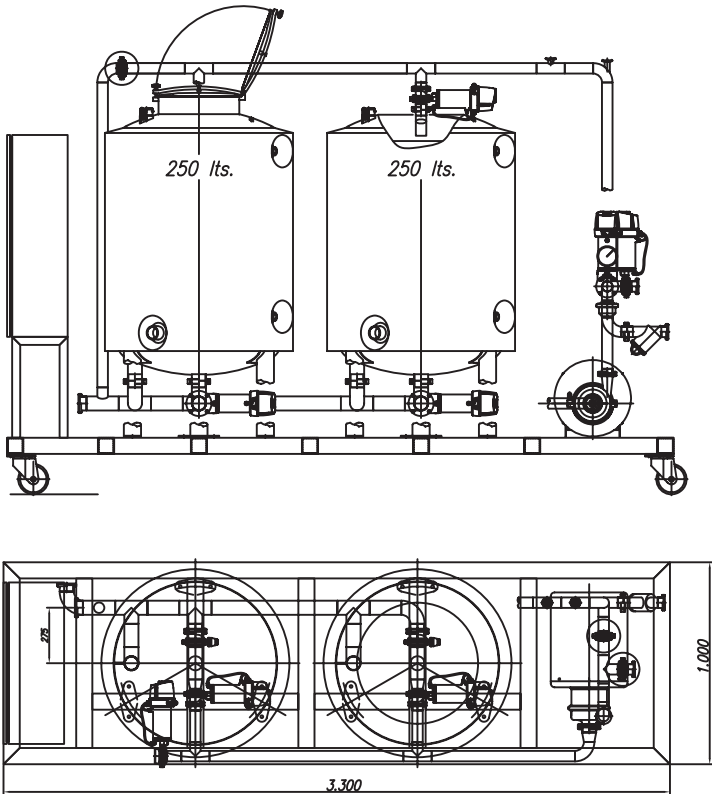

One line static CIP unit

