

MODEL C-CS “CLEAN STEAM” PRESSURE REDUCING REGULATOR

SECTION I

I. DESCRIPTION AND SCOPE

Model C-CS is a pressure reducing regulator used to control downstream (outlet or P_2) pressure. Inlet and outlet sizes are 3/4" (DN20), 1" (DN25), 1-1/2" (DN40), 2" (DN50) and 3" (DN80) with Tri-Clamp® fitting connections. This regulator is primarily designed for steam service at temperatures equal to or less than 366°F (185°C); this corresponds to 150 psig (10.3 Barg) saturated steam; however, the unit may also be used for clean gaseous or liquid applications.

⚠ CAUTION

The Model C-CS should never be used as a shut-off device.

SECTION II

II. INSTALLATION

1. An inlet block valve should always be installed.
2. If service application is continuous such that shutdown is not readily accomplished, it is recommended that inlet and outlet block valves and a manual bypass valve be installed.
3. An outlet pressure gauge should be located approximately ten pipe diameters downstream and within sight.
4. All installations should include a downstream relief device if the inlet pressure could exceed the pressure rating of any downstream equipment.
5. Flow Direction: Install so the flow enters through the bottom connection and exits the side connection.
6. Install in a well drained pipe, properly trapped, with spring chamber (2) in the vertical position to allow for proper draining.

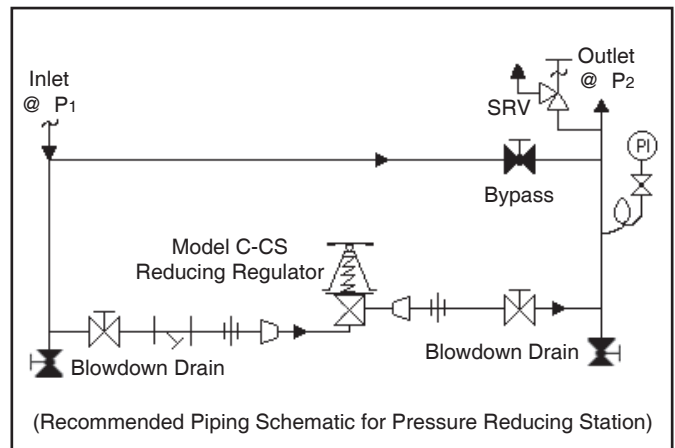

7. For insulated piping systems, the regulator should not be insulated.

⚠ CAUTION

Installation of adequate overpressure protection is recommended to protect the regulator from overpressure and all downstream equipment from damage in the event of regulator failure.

SECTION III

III. PRINCIPLE OF OPERATION

1. Movement occurs as pressure variations register on the diaphragm. The registering pressure is the outlet, P_2 or downstream pressure. The range spring opposes diaphragm movement. As the outlet pressure drops, the range spring pushes the diaphragm down,

⚠ CAUTION

Do not apply spring load or operate regulator with hitch pin (21) removed from top of guide post (27). Premature diaphragm failure will result.

opening the port; as outlet pressure increases, the diaphragm pushes up and the port closes.

2. A complete diaphragm failure will cause the regulator to fail open.

SECTION IV

IV. START-UP

NOTE: *The regulator set point must be set under normal flowing conditions.*

1. CCW = Counter Clockwise,
CW = Clockwise.
2. Inspect the unit's nameplate to confirm that the proper range spring is installed in the regulator. Apply setpoint pressures that are only within the stated range.
3. Start with the block valves closed. A bypass valve may be used to maintain outlet pressure in the downstream system while performing the following steps.
4. Relax compression of range spring (7) by turning handle (6) counter-clockwise (CCW) until rotation stops. Rotate handle (6) clockwise (CW) three (3) full revolutions to maintain spring (7) to diaphragm(17) contact. This reduces the outlet pressure setpoint.
5. If piping system includes a bypass valve, slowly open the bypass valve to preheat the system piping and to allow slow expansion of the piping. Ensure proper steam trap operation, if installed. To prevent overpressurization, closely monitor outlet (downstream) pressure with a gauge. **NOTE:** *If no bypass valve is installed, extra caution should be used in starting up a cold system; i.e. do everything slowly.*
6. Crack open the outlet (downstream) block valve.

7. Slowly open the inlet (upstream) block valve observing the outlet (downstream) pressure gauge. Determine if the regulator is flowing (*see NOTE above step 1*). If no flow, rotate the regulator handle (6) CW (viewed from above) until flow begins. Determine if downstream equipment is in operation.
8. Continue to slowly open the inlet (upstream) block valve until fully open.
9. Continue to slowly open the outlet (downstream) block valve. When flow is established steady enough that the outlet (downstream) block valve is fully open, begin to slowly close the bypass valve, if installed, until fully closed.
10. Develop system flow to a level near its expected normal rate and reset the regulator setpoint by turning the handle (6) CW (viewed from above) to increase outlet pressure or CCW to reduce outlet pressure.
11. Reduce system flow to a minimum level and observe setpoint. Outlet pressure will rise from the setpoint of Step 10. The maximum rise in outlet pressure on decreasing flow should not exceed the stated upper limit of the range spring by greater than 30%; i.e. 10-30 psig (.69-2.1 Barg) range spring – at low flow the outlet pressure should not exceed 39 psig (2.7 Barg). If it does, consult factory.

SECTION V

V. SHUTDOWN

1. On systems with a bypass valve, and where system pressure is to be maintained as the regulator is shutdown, slowly open the bypass valve while closing the inlet block valve. Fully close the inlet block valve. When on bypass, the system pressure must be constantly observed and manually regulated.

2. If the regulator and system are to both be shutdown, slowly close the inlet block valve. Close the outlet valve only if regulator removal is required.

CAUTION

DO NOT DEAD-END FLOW DOWNSTREAM of the Model C-CS as over pressurizing regulator may damage internals.

SECTION VI

VI. MAINTENANCE

WARNING

SYSTEM UNDER PRESSURE. Prior to performing any maintenance, isolate the regulator from the system and relieve all pressure. Failure to do so could result in personal injury.

A. General:

1. Maintenance procedures hereinafter are based upon removal of the regulator unit from the pipeline where installed.
2. Refer to Figures 2 & 3 for basic regulator item number reference () and description.

B. Diaphragm – Trim Replacement:

1. Securely install the regulator in a soft-jawed vise with the spring chamber (2) directed upwards. Ensure that the body (1) is not held in the vise by the Tri-clamp® fitting connections. The regulator may be held in the vise with flats on the plug (14). If this method is used, ensure that the plug (14) is in contact with the seating area of the body (1) and the face of the inlet flange of the body (1) is resting on the vise.

WARNING

SPRING UNDER COMPRESSION. Relieve all spring (7) compression prior to removing clamp (13). Failure to do so may result in flying parts that could result in personal injury.

2. Relax range spring (7) by turning handle (6) CCW (viewed from above) until rotation stops. Count and record the number of revolutions in the box below:

Number of revolutions required to relax range spring: _____

CAUTION

Do not apply spring load or operate regulator with hitch pin (21) removed from top of guide post (27). Premature diaphragm failure will result.

3. Remove socket head set screw (30) CCW from end of guide post (27).

4. Pull hitch pin (21) and lift up on handle (6) to remove.
5. Loosen and remove clamp nuts (13B), washers (13D), bolts (13C) and clamps (13A). See Figure 1.
6. Place matchmarks between body (1) and spring chamber (2) to assist in final orientation when reassembled. Lift spring chamber (2) vertically up and off of body (1) and above guide post (27) to remove. *Note alignment of spring button (4) tabs (ears) with respect to slot guides inside spring chamber (2).*
7. Remove bearing (26). Lift up and remove adjusting screw cap (25.7) and dowel pin (25.8) assembly. **NOTE:** *May need to tap lightly on O.D. of adjusting screw (25.6) to free Dowel pin (25.8) from adjusting screw (25.6).*
NOTE: *The two guide seals (25.9) may/may not be extracted with assembly (25.7,25.8). Remove guide seals (25.9).*
8. Lift up the adjusting screw (25.6) and spring button (4) as an assembly to remove. **NOTE:** *Do not rotate or remove spring button (4) from adjusting screw (25.6).* Remove spring (7) and lay aside.
9. **For Metal Seat:** Secure the pressure plate assembly (27,28 and 29) at the "flats" near the base of pressure plate (28). Grasp the lower portion of the plug (14) by the "flats", which protrudes from the body (1) inlet, with soft-jawed pliers or soft-jawed vise and proceed to turn CCW (viewed from above) for disassembly. **NOTE:** *Maintain firm grasp of plug (14). After disengagement, plug (14) could fall out of body (1) and damage seating surface area. Remove plug (14).*
For Composition Seat: The tail piece (14.3) may disengage at the plug stem (14.1) joint, instead of at pressure plate joint(28). If it does, lift plug stem and pressure plate assembly out of the body cavity.
Remove seat disc (14.2) from tail piece. Secure "winged" end of stem (14.1) in a soft-jawed vise. Use the "flats" on the pressure plate to rotate CCW to remove pressure plate assembly.
10. Lay pressure plate assembly (27,28 and 29) aside. **NOTE:** *The travel of the guide post (27) has been factory set. Do not loosen or adjust the hex nut (29) on pressure plate assembly (27,28,29).*

11a. **For Model C-CS :**

Remove diaphragm (17), O-ring (16), diaphragm gasket (15) and body (1).

11b. **For Model C-CS with Opt.-11:**

Remove diaphragm (17), diaphragm gaskets (15), O-ring (18), seal (19), pusher plate (20), O-ring (16) and body (1).

12. Inspect plug (14) and seating surface of body (1) for excessive wear. For composition seat -install new soft seat (14.2) in tail piece (14.3).
13. Inspect gasket (15) and O-ring (16) retaining surfaces of body (1) and spring chamber (2).
14. Clean all parts in accordance with Owner's cleaning procedures. Secure plug (14) or tail piece (14.3) back into vise. Set body (1) over top of plug. Ensure that the plug or seat of tail piece is in contact with the seating area of the body (1) and the face of the inlet flange of the body (1) is resting on the vise.

For Composition Seat: Place a small amount of medium strength, Food Grade threadlocker on threaded end of stem (14.1). Insert threaded end of stem into tail piece.

15. Place new diaphragm gasket (15) on body (1) flange.
16. Install O-ring (16) on plug (14). For Opt.-11 reposition pusher plate (20) on threaded end of plug and install O-ring (18) and seal (19). Refer to Figure 4.
17. Place diaphragm (17) over threaded end of plug (14). **NOTE:** The word 'TOP' is etched on one side of the diaphragm and should be visible when looking down on the diaphragm.
18. Place a small amount of medium strength, Food Grade threadlocker on threaded end of plug (14). Reassemble pressure plate assembly (27,28 and 29) to plug (14). Refer to **NOTE:** in Step 10. Grasp the parts and rotate pressure plate assembly (27,28,29) CW until wrench tight (metal-to-metal contact); Torque values not to exceed the following:

Body Size in (DN)	Torque in-lbs (N-m)
3/4"-1 1/2" (20-40)	100 (11)
2" - 3" (50-80)	270 (31)

19. Center/align the above pressure plate/diaphragm assembly on the diaphragm (17) flange surface in the body (1) cavity.

20. Position spring (7) on to hub of pressure plate (28). Place adjusting screw (25.6) - with spring button (4) - over end of guide post (27) and into spring (7) cavity. **NOTE:** Apply a small amount of Emhart Bostik White Food Grade "Never-Seez" or equivalent to threads of adjusting screw (25.6) **Do Not rotate adjusting screw (25.6) or spring button (4).**

21. Firmly hold the spring chamber (2) down. Insert a suitable tool into the hitch pin hole in the top of the guide post (27). Turn the guide post to set the proper travel measurement. Measure from the bottom of the guide post hole to the top of chamber nut (6) . Refer to Figure 1. Set as follows:

Down Stop Height Setting	
Size (port)	Measurement 'A' - inch
3/4" and 1" (All Ports) 1-1/2" (Reduced Port)	0.115"
1-1/2" (Full Port) 2" and 3"	0.150"

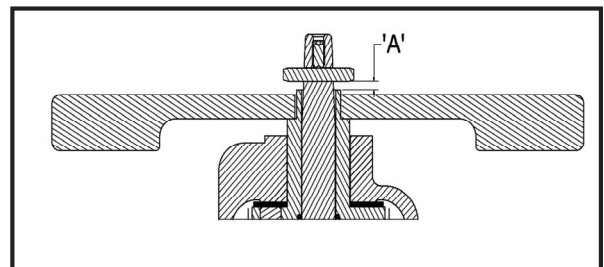

Figure 1: Down Stop Measurement

22. After setting this measurement, remove the spring chamber (2) without changing the position of the guide post (27). Secure the height adjustment of the guide post by tightening the jam nut (29). **Note:** Loctite should be applied to the height locking threads. Repeat step 17 to position loading chamber (2) on body (1).
23. Install new guide seals (25.9) in adjusting screw cap (25.7). **NOTE:** There are two sizes of u-cup seals - install the seal with the bigger diameter spring first, open face into the cap recess. Install the second u-cup seal, open face exposed to face of adjusting screw (25.6). Slide adjusting screw cap (25.7) over end of guide post (27). Align dowel pin (25.8) with hole in adjusting screw (25.6) and press together by hand. **NOTE:** Top of dowel pin (25.8) should be flush with top surface of adjusting screw cap (25.7).

24. Install new bearing (26) on top of upper guide assembly (25).
25. Align slot guides inside spring chamber (2) with spring button (4) tabs (ears) and position on to body (1). Align with match marks of step 6. previous.
26. Place handle (6) over end of guide post (27) coming to rest on adjusting screw cap (25.7). Insert hitch pin (21) into hole through end of guide post (27). Apply Food Grade threadlocker to threads of set screw (30) install into top of guide post (27) and tighten securely.
27. Reposition clamps (13A) around body (1) and spring chamber (2) flanges. Insert clamp bolts (13C), washers (13D) and tighten clamp nuts (13B) in alternating pattern.

NOTE: Gap between clamp (13A) halves should be equal in size. Gap and torque requirements are as follows:

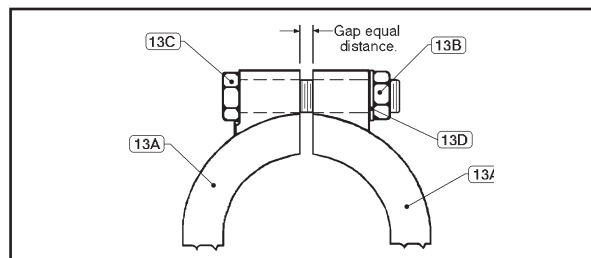

Figure 1: Clamp Arrangement.

Gap	Torque
Equal Distance	225-250 in-lbs (25-28 N-m)

28. Reapply compression to the range spring (7) by rotating handle (6) CW as per the number of revolutions recorded in VI.B.2.
29. Return to Section II for Installation and Section IV for Start-up.

SECTION VII

VII. ORDERING INFORMATION NEW REPLACEMENT UNIT vs PARTS "KIT" FOR FIELD REPAIR

To obtain a quotation or place an order, please retrieve the Serial Number and Product Code that was stamped on the metal name plate and attached to the unit. This information can also be found on the Bill of Material ("BOM"), a parts list that was provided when unit was originally shipped. (Serial Number typically 6 digits). Product Code typical format as follows: (last digit is alpha character that reflects revision level for the product).

□□□□ - □□□□ 7 - □□□□□□□□□□

NEW REPLACEMENT UNIT:

Contact your local Cashco, Inc., Sales Representative with the Serial Number and Product code. With this information they can provide a quotation for a new unit including a complete description, price and availability.



CAUTION

Do not attempt to alter the original construction of any unit without assistance and approval from the factory. All purposed changes will require a new name plate with appropriate ratings and new product code to accommodate the recommended part(s) changes.

PARTS "KIT" for FIELD REPAIR:

Contact your local Cashco, Inc., Sales Representative with the Serial Number and Product code. Identify the parts and the quantity required to repair the unit from the "BOM" sheet that was provided when unit was originally shipped.

NOTE: Those part numbers that have a quantity indicated under "Spare Parts" in column "A" reflect minimum parts required for inspection and rebuild, - "Soft Goods Kit". Those in column "B" include minimum trim replacement parts needed plus those "Soft Goods" parts from column "A".

If the "BOM" is not available, refer to the cross-sectional drawings included in this manual for part identification and selection.

A Local Sales Representative will provide quotation for appropriate Kit Number, Price and Availability.

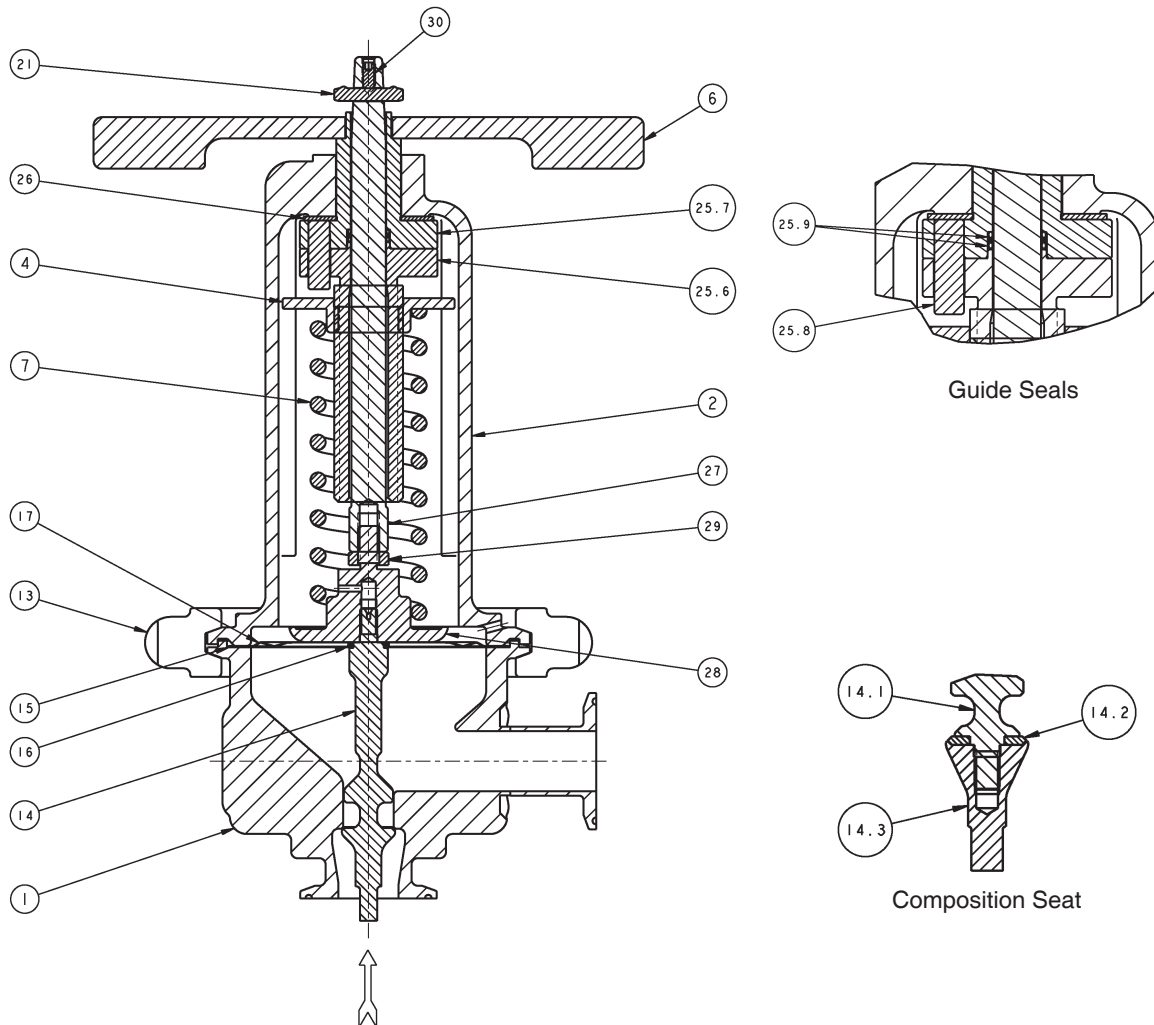

Figure 2
Barstock body
Metal Seat

Item No.	Description	Repair Parts		Item No.	Description	Kit A	Kit B
		Kit A	Kit B				
1	Body			25	Upper Guide Assembly		
2	Spring Chamber			25.6	Adjusting Screw		
4	Spring Button			25.7	Adjusting Screw Cap		
6	Handle			25.8	Dowel Pin		
7	Range Spring			25.9	Guide Seals (2 Req'd)	*	*
13	Clamp ¹			26	Bearing		
14	Plug		*	27	Guide Post		
14.1	Stem		*	28	Pressure Plate		
14.2	Seat		*	29	Nut Hex Jam		
14.3	Tail Piece		*	30	Set Screw		
15	Gasket (Diaphragm)	*	*				
16	O-ring (Plug)	*	*				
17	Diaphragm	*	*				
18	O-ring	*	*				
19	Seal	*	*				
20	Pusher Plate						
21	Hitch Pin						
Not Shown:							
<u>Item No.</u>	<u>Description</u>						
11	Name Plate						
12	Drive Screw						

* Recommended Spare Part

¹ Refer to Figure 1 for Clamp and related item numbers.

See the previous page for Item Number and Descriptions

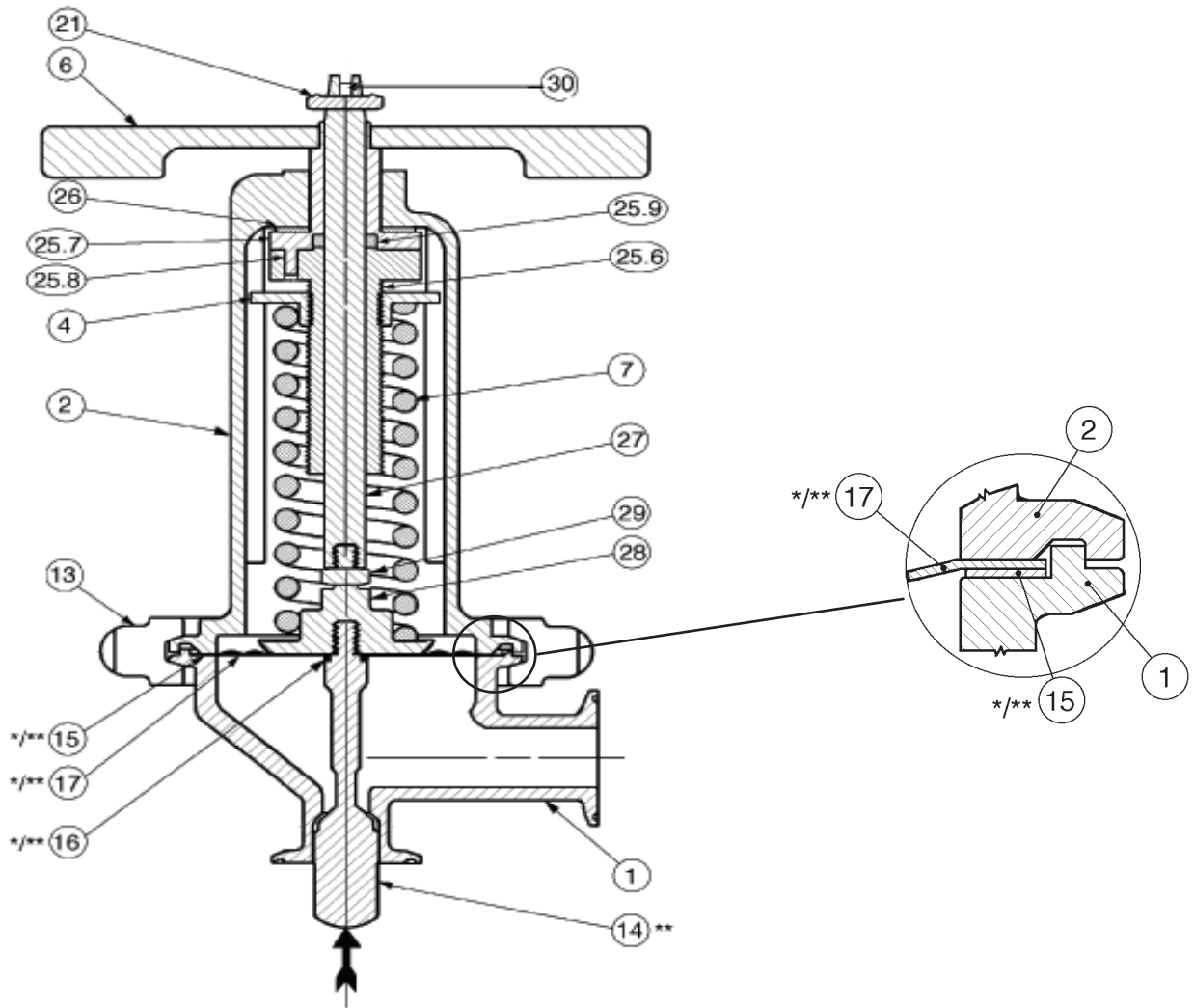

Figure 3
Investment Cast body

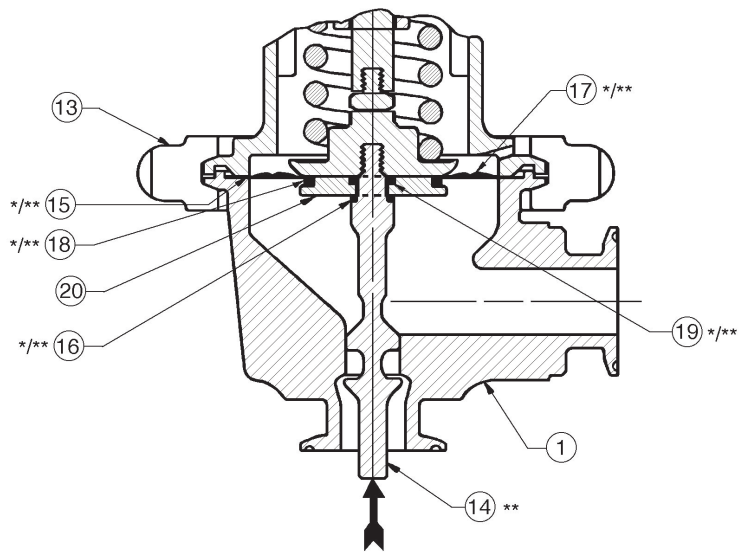

Figure 4: Option-11, Diaphragm Restraint
(Barstock Body Only)



IOM ADDENDUM:

ATEX DIRECTIVE 2014/34/EU and THE EQUIPMENT AND PROTECTIVE SYSTEMS INTENDED FOR USE IN POTENTIALLY EXPLOSIVE ATMOSPHERES REGULATIONS 2016

Cashco, Inc. declares that the products listed in the table below has been found to comply with the Essential Health and Safety Requirements relating to the design and construction of products intended for use in potentially explosive atmospheres given in Annex II of the ATEX Directive 2014/34/EU and given in Schedule 1 of The Equipment and Protective Systems Indented for Use in Potentially Explosive Atmospheres Regulations 2016. Compliance with the Essential Health and Safety Requirements has been assured by compliance with EN ISO 80079-36:2016 and EN ISO 80079-37:2016. The product will be marked as follows:



The 'X' placed after the technical file number indicates that the product is subject to specific conditions of use as follows:

1. The maximum surface temperature depends entirely on the operating conditions and not the equipment itself. The combination of the maximum ambient and the maximum process medium temperature shall be used to determine the maximum surface temperature and corresponding temperature classification, considering the safety margins described prescribed in EN ISO 80079-36:2016, Clause 8.2. Additionally, the system designer and users must take precautions to prevent rapid system pressurization which may raise the surface temperature of system components and tubing due to adiabatic compression of the system gas. Furthermore, the Joule-Thomson effect may cause process gases to rise in temperature as they expand going through a regulator. This could raise the external surface temperature of the regulator body and the downstream piping creating a potential source of ignition. Whether the Joule-Thomson effect leads to heating or cooling of the process gas depends on the process gas and the inlet and outlet pressures. The system designer is responsible for determining whether the process gas temperature may raise under any operating conditions.
2. Where the process medium is a liquid or semi-solid material with a surface resistance in excess of $1G\Omega$, special precautions shall be taken to ensure the process does not generate electrostatic discharge.
3. Special consideration shall be made regarding the filtration of the process medium if there is a potential for the process medium to contain solid particles. Where particles are present, the process flow shall be $<1\text{m/s}$ ($<3.3\text{ ft/s}$) in order to prevent friction between the process medium and internal surfaces.
4. Effective earthing (grounding) of the product shall be ensured during installation.
5. The valve body/housing shall be regularly cleaned to prevent build up of dust deposits.
6. Regulators must be ordered with the non-relieving option (instead of the self-relieving option) if the process gas they are to be used with is hazardous (flammable, toxic, etc.). The self-relieving option vents process gas through the regulator cap directly into the atmosphere while the non-relieving option does not. Using regulators with the self-relieving option in a flammable gas system could create an explosive atmosphere in the vicinity of the regulator.
7. Tied diaphragm regulators with outlet ranges greater than 7 barg (100 psig) should be preset to minimize the risk that improper operation might lead to an outboard leak and a potentially explosive atmosphere.
8. All equipment must only be fitted with manufacturer's original spare parts.
9. Ensure that only non-sparking tools are used, as per EN 1127-1, Annex A.

	PRODUCT
REGULATORS	31-B, 31-N
	1164, 1164(OPT-45)
	1171, 1171(OPT-45), 1171(CRYO)
	2171, 2171(OPT-45), 2171(CRYO), 3171
	1465, 3381, 3381(OPT-45), 3381(OPT-40)
	4381, 4381(OPT-37), 4381(CRYO), 4381(OPT-45), 5381
	MPRV-H, MPRV-L
	PBE, PBE-L, PBE-H
	CA-1, CA-2
	CA1, SA1, CA4, SA4, CA5, SA5
	DA2, DA4, DA5, DA6, DA8
	DA0, DA1, DAP, SAP
	SLR-1, SLR-2, PTR-1
	ALR-1, ULR-1, PGR-1
	BQ, BQ(OPT-45), BQ(CRYO)
	123, 123(CRYO), 123(OPT-45), 123(OPT-46G)
	123-1+6, 123-1+6(OPT-45), 123-1+6(OPT-46G), 123-1+6+S, 123-1+6+S(OPT-40)
	1000HP, 1000HP(OPT-37), 1000HP(OPT-45), 1000HP(OPT-45G), 1000HP(CRYO)
	1000HP-1+6, 1000HP-1+8, 1000LP, 1000LP(OPT-45), 1000LP(OPT-46G)
	6987
	8310HP, 8310HP-1+6, 8310HP-1+8, 8310LP, 8311HP, 8311LP
	345, 345(OPT-45)
	BA1/BL1, PA1/PL1
	C-BPV, C-PRV, C-CS
	D, D(CRYO), D(OPT-37), D(OPT-20), D(OPT-45)
	DL, DL(LCC), DL(OPT-45)
	BR, BR(CRYO)
	HP, HP(LCC), HP(OPT-45), HP(OPT46G), HP-1+6+S(OPT-40), HP-1+6+S
	P1, P2, P3, P4, P5, P7
	B2, B7
	POSR-1, POSR-2
	5200P, 5300P
	135
NW-PL, NW-SO	
CG-PILOT	
FG1	
CONTROL VALVES	RANGER, 987, PREMIER
	964, 521, 988, 988-MB, 989
	2296/2296HF
	SCV-30, SCV-S
TANK BLANKETING	8700, 8910, 8920, 8930, 8940
	2100, 2199
	3100, 3200, 3300, 3400, 3500, 3600, 3700
	1078, 1088, 1100, 1049
	5100, 5200, 5400, 5500
	4100, 4200, 4300, 4400, 4500, 4600
MISC	764P/PD, 764-37, 764T

Cashco, Inc.
P.O. Box 6
Ellsworth, KS 67439-0006
PH (785) 472-4461
Fax. # (785) 472-3539
www.cashco.com
email: sales@cashco.com
Printed in U.S.A. IOM-C-CS

Cashco GmbH
Handwerkerstrasse 15
15366 Hoppegarten, Germany
PH +49 3342 30968 0
Fax. No. +49 3342 30968 29
www.cashco.com
email: germany@cashco.com

Cashco do Brasil, Ltda.
Al.Venus, 340
Indaiatuba - Sao Paulo, Brazil
PH +55 11 99677 7177
Fax. No.
www.cashco.com
email: brazil@cashco.com