



Valve Concepts, Inc.  
ISO Registered Company



## Model 1078

### Vacu-Gard® Tank Blanketing Valve

1" & 2" (DN25 & DN50)

The Model 1078 is a pilot-operated valve, specifically designed to reduce blanketing gas losses on low-pressure storage tanks. It opens and closes automatically as required, to maintain a closely controlled blanket pressure. The simple design, increases reliability and lowers maintenance cost.

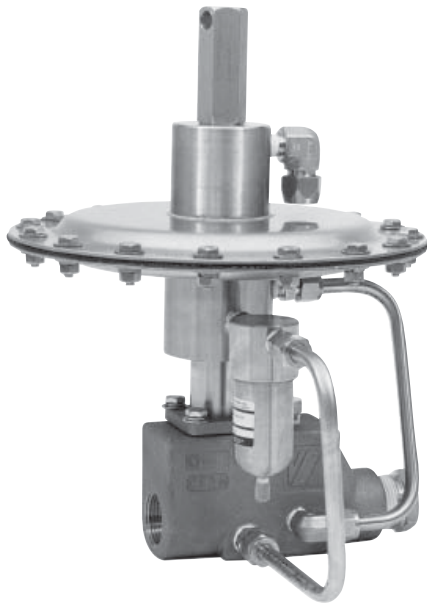

1" Model 1078

U.S. Pat. No. 4991620, 5067522 and 5094267

### Application

On many low-pressure storage tanks the operating range is very low, which makes blanketing and venting system selection/design a challenge for the engineer. The Vacu-Gard® makes the job much easier. First, the Vacu-Gard® set point definition is where the blanketing valve closes bubble tight. This gives the largest dead bubble band between the blanketing valve set point and the set point of the relieving device, and therefore will reduce losses. Second, the Vacu-Gard® has a wide range of available settings, from vacuum to 14 psig, that make proper selection easier.

### FEATURES

- Versatile:** Single valve system offers wide variety of configurations to meet every blanketing application. Self cleaning flow design.
- Top entry Design:** Compact and light weight yet allows complete access to the valve internals without being removed from the tank. Only time the diaphragm case needs to be disassembled is when replacing the diaphragm.
- Stability:** Pressure balanced pilot. Fluctuations in supply pressure does not affect set point.
- Performance:** Valve set point can be verified 100% on the tank, without removal and without flowing supply gas into the tank. Temperature changes have no appreciable effect on set point.
- Shutoff:** Bubble tight at set point, prevents waste of blanketing gases.
- Lower Maintenance Costs:** Uses standard o-rings for seat and seals.

## GENERAL SPECIFICATIONS

### Sizes

1" (DN25) Body  
2" (DN50) Body

### Connections

1" & 2" FNPT (screwed)  
1" 150# integral RF flanges'  
1" 300# weldneck RF flange  
2" 150# & 300# RF weldneck flanges  
DN25 (PN40), DN50 (PN16) & DN50 (PN40)  
weldneck flanges.  
Special configurations are available on request:  
Any combination of above.  
Larger size reducing flanges .

### Outlet Configurations

Horizontal or Vertical

Valves with FNPT connections can be configured in the field. Valves with weldneck flange connections, configuration must be specified at time of order.

### Sensing Options

Remote sensing  
Integral dip tube sensing (Vertical Outlet Only)

### Supply Pressures

Minimum: 20 psig (1.38 Bar)  
Maximum: 200 psig (13.83 Bar)

### Pressure - Temperature Specifications

Body Material	End Connection	Inlet Pressure	Temperature F(C)*
Carbon Steel **	NPT, 150# & 300#Flange	200 psig (13.8 Barg)	-20 to 400 (-29 to 204)
Stainless Steel A352 CF3M	NPT & 300# Flange	200 psig (13.8 Barg)	-50 to 400 (-45 to 204)
	150# Flange	200 (13.8 Barg)	-325 to 300 (-198 to 149)
		195 (13.4 Barg)	-325 to 400 (-198 to 204)
Hastelloy C®	NPT, 150# & 300#Flange	200 (13.8 Barg)	-50 to 400 (-45 to 204)

\* Design temperature limits maybe restricted by trim selection

\*\* Only available in 2" (DN50) Size.

Hastelloy® is a registered trade name:  
Hastelloy® is a mark owned by Stelite Div., Cabot Corp.

### Capacities

See Table 6

### Outlet Pressure Ranges

See Table 3

### Maximum Back Pressures

25 psig (1.7 Bar)

### Materials of Construction

Diaphragm Case Material:  
Carbon Steel (Powder Coated)  
Stainless Steel  
Hastelloy C®  
Trim Material:  
316 Stainless Steel  
Hastelloy C®  
Diaphragm Material:  
PTFE  
Soft Seat & Seals:  
FKM is standard;  
Buna-N, EPDM,  
FFKM 1 - Similar to Chemraz  
FFKM 2 - Similar to Kalrez

### Temperature Limits

Seat & Seal Materials  
FKM (Fluorocarbon Elastomer):  
-15° to 300° F (-26° to 149° C)  
Buna-N (Nitrile-NBR):  
-40° F to 212° F (-40° C to 100° C)  
EPDM (Ethylenepropylene):  
-55° F to 212° F (-48° C to 100° C)  
FFKM 1 (Perfluoroelastomer):  
-22° F to 400° F (-30° C to 204° C)  
FFKM 2 (Perfluoroelastomer):  
-40° F to 400° F (-40° C to 204° C)

### Paint

Standard: Exterior coating will be a combination of Cashco Paint Specs #S-1777 epoxy and #S-1743 powder coated. Tubing, fasteners, seat surfaces - corrosion resistant parts excluded.

Alternate Paint: See Opt-95OS.

## CAPACITY REQUIREMENTS

The capacity requirement of the tank blanketing valve is the sum of two components. The first being inbreathing due to liquid or product movement out of the tank and the second being inbreathing due to contraction of the vapors/product because of weather changes.

Inbreathing due to maximum liquid or product movement out of the tank equals 8.0 SCFH of air for each US gallon per minute of maximum emptying rate or 0.94 Nm<sup>3</sup>/h of air for each m<sup>3</sup>/h of maximum emptying rate.

**Q displacement (SCFH) = Max. Pumpout Rate (gpm) x 8.0**  
or

**Q displacement (Nm<sup>3</sup>/h) = Max. Pumpout Rate (m<sup>3</sup>/h) x .94**

The second component, inbreathing due to weather changes, is selected from Table 5 (Table 5A). The tank capacity is found in column 1 and the corresponding inbreathing requirement is selected from column 2.

The two components are added together to give the total inbreathing requirement and the capacity requirement of the tank blanketing valve.

$$Q_{\text{total}} = Q_{\text{displacement}} + Q_{\text{thermal}}$$

## VALVE SELECTION

If the tank blanketing supply pressure varies, use the minimum supply pressure in selecting the tank blanketing valve and the maximum supply pressure to determine blanketing valve failure capacity. Using the minimum supply pressure, select the size value from Table 6 that will meet the Total Inbreathing Requirement (Q total). Next determine if a reducing "flow plug" can be used to make the capacity of the tank blanketing valve more closely match the inbreathing requirements. This will also reduce the fail open capacity of the blanketing valve. This is done by dividing the required inbreathing (Q total) by the full capacity of the size valve selected and multiplying by 100. Now from Table 2, choose the flow plug that is greater than the calculated percentage.

Example:

Total inbreathing requirement (Q total) = 25,850 SCFH  
Maximum supply pressure = 100 psig  
Minimum supply pressure = 80 psig

Next divide the total inbreathing requirement of 25,850 SCFH by the 1" valve capacity of 35,990 SCFH (at 80 psig) and multiply by 100.

$$(25,850 \text{ SCFH} / 35,990 \text{ SCFH}) \times 100 = 71.8\%$$

From Table 2, a 75% flow plug would be chosen for a 1" valve. With the 75% flow plug, the blanketing valve will flow 26,993 SCFH at 80 psig and at the maximum supply pressure of 100 psig it will flow 32,693 SCFH. The 32,693 SCFH also represents the fail open flow of the blanketing valve and will be used in sizing the pressure relieving device.

## NORMAL INSTALLATION

Model 1078 Pilot Operated Vacu-Gard<sup>®</sup> Tank Blanketing Valve

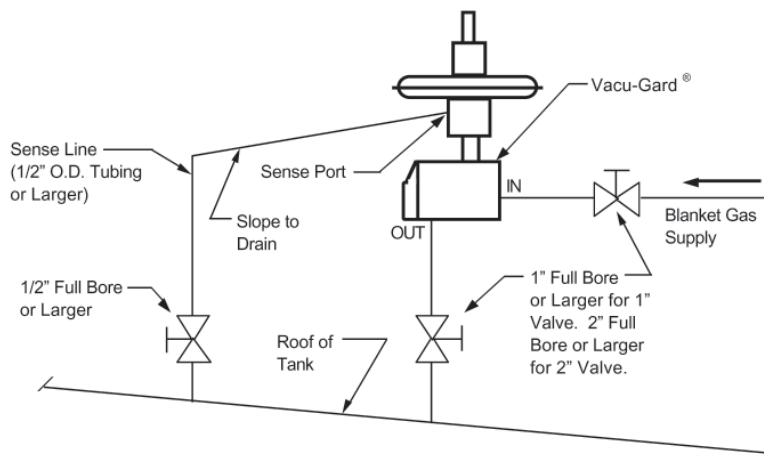

# VALVE OPERATION

## Closed Position

Figure 1 shows the Vacu-Gard® in the closed position. This occurs when the tank pressure satisfies or exceeds the set pressure of the pilot. When the sensed pressure is sufficient to overcome the downward force of the set pressure spring, the pilot will close and there is no flow out of the pilot. This causes full supply pressure to accumulate in the chamber above the main valve piston. Since the piston area is larger than the seat area at the lower end of the piston, when the pressure above the piston is equal to the supply pressure the piston will move downward to close the valve due to the presence of a higher downward force.

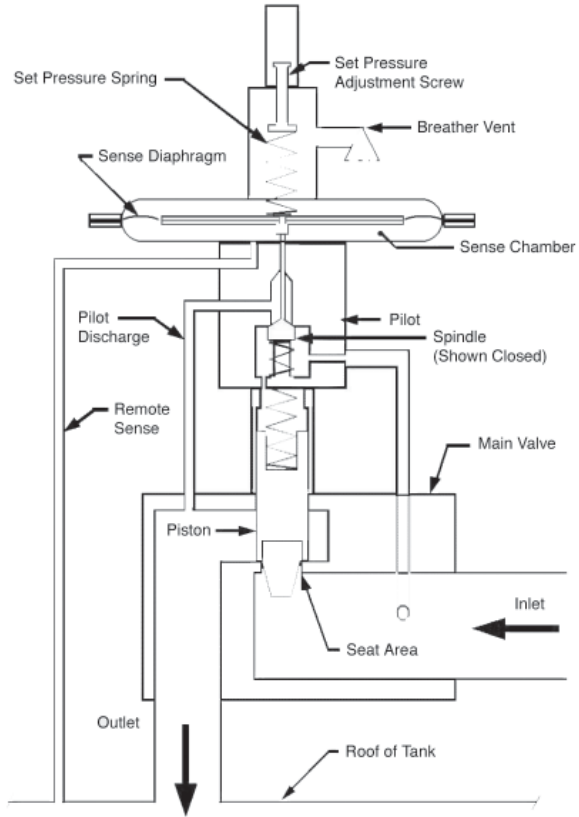
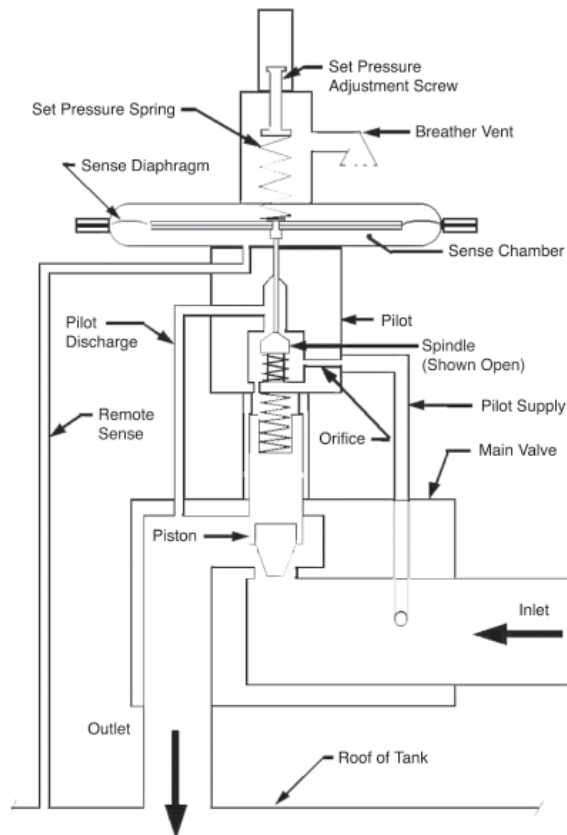

**Figure 1**

## Open Position

Figure 2 shows the Vacu-Gard® in the open position. When the tank pressure, that is sensed in the sense chamber below the diaphragm, is insufficient to hold against the downward force of the set pressure spring, the spindle in the pilot chamber will be forced downward. As the spindle unseats, the pressure in the pilot chamber will be discharged into the outlet of the valve. A small orifice restricts the gas flow into the pilot chamber from the supply pressure. Therefore, as soon as the pilot spindle opens, the pilot chamber pressure will drop significantly and will not be able to hold the main valve piston down. The piston will now be pushed full open by the supply pressure, allowing a maximum flow of the blanketing gas into the tank.

Once the tank pressure is back to set point, the spindle will close and the pilot pressure will rise to full supply pressure, pushing the main valve piston back down into the fully closed position.



**Figure 2**

TABLE 1									
STANDARD MATERIALS OF CONSTRUCTION									
SIZE	MAIN BODY *	PILOT BODY	DIAPHRAGM CASES	SPRING BONNET	TRIM	SENSE DIAPH	SPRING (3 places)	TUBING FITTINGS	TUBING
1"	316 SST (C)	303 SST	CS	CS	316 SST	PTFE	302 SST	316 SST	316 SST
	316 SST (D)	303 SST	CS	CS					
	316 SST (S)	316 SST	304 SST **	304 SST					
	316 SST (W)		CS (upper)						
304 SST (lower)**									
2"	CS (C)	303 SST	CS	CS	316 SST	PTFE	302 SST	316 SST	316 SST
	CS (D)	303 SST	CS	CS					
	316 SST (S)	316 SST	304 SST **	304 SST					
	316 SST (W)		CS (upper)						
304 SST (lower)**									
1" & 2"	Ni-Mo-Cr (H) Hastelloy C®	Hastelloy C®	CS (upper) Hastelloy C®	CS	Hastelloy C®	PTFE	302 SST (upper 1) Hastelloy	Hastelloy C®	Hastelloy C®

\* Character within ( ) is material code from Position 5 of Coder.  
\*\* 316 SST Material for NACE construction

TABLE 2		
STANDARD FLOW PLUG FLOW COEFFICIENTS for RELIEF SIZING (WIDE-OPEN Cv)		
FLOW PLUG PERCENTAGE (%)	1" SIZE	2" SIZE
100	11.1	48
80	-	38
75	8.3	-
60	-	29
50	5.6	-
40	-	19
25	2.8	-
20	-	10
10	1.1	-

TABLE 3	
OUTLET PRESSURE RANGES	
0.50" to 5" WC	(1.24 - 12.4 mbar)
5" to 14" WC	(12.4 - 34.8 mbar)
14" to 30" WC	(34.8 - 74.7 mbar)
1.0 to 1.5 psig	(69 - 103 mbar)
1.5 to 3.0 psig	(103 - 207 mbar)
3.0 to 14.0 psig	(0.2 - 0.96 bar)
0" to 1-1/2" WC (vac)	(0 - 3.7 mbar)
1-1/2" to 6" WC (vac)	(3.7 - 14.8 mbar)

TABLE 4		
SET POINT	MAXIMUM INLET PRESSURE (Consult Factory for Higher Inlet Pressures)	
	1" SIZE	2" SIZE
0.50" - 0.70" w.c. (1.24 - 1.8 mbarg) (Please consult the factory.)	100 psig (6.9 barg)	N/A
0.75" - 1.00" w.c. (1.9 - 2.5 mbarg)	125 psig (8.6 barg)	100 psig (6.9 barg)
1.05" - 14" w.c. (2.6 - 34.5 mbarg)	200 psig (13.8 barg)	150 psig (10.3 barg)
0.51 - 14.0 psig (0.035 - 0.96 barg)	200 psig (13.8 barg)	200 psig (13.8 barg)
INLET PRESSURE		
MINIMUM	20 psig (1.38 barg)	
RECOMMENDED	≥ 35 psig (2.41 barg)	

**STANDARD INFORMATION**

**The tank blanketing valve is not a substitute for the vacuum relief device.**

API Standard 2000 states, "The design of a gas repressuring system to eliminate the requirement for vacuum relief valves is beyond the scope of this standard and should be considered only when the induction of air represents a hazard equal to or greater than failure of the tank".

**The tank blanketing valve failure must be taken into account when considering possible causes of overpressure in a tank.**

API Standard 2000 states, "When the possible causes of overpressure or vacuum in a tank are being determined, other circumstances resulting from equipment failures and operating errors must be considered and evaluated by the designer." Failure of the tank blanketing valve can result in unrestricted gas flow into the tank, reduced gas flow or complete loss of the gas flow.

**Tank blanketing valve set point definition is not the same for all manufacturers.**

Valve Concepts defines set point as the point where the tank blanketing valve is closed bubble tight!

Some manufacturers define the set point as where the blanketing valve opens and the valve requires a pressure above the set point in order to close completely. Others define set point somewhere in between opening and closing but still the pressure must go above the defined set point in order to close completely.

The following example illustrates Valve Concepts definition of set point:

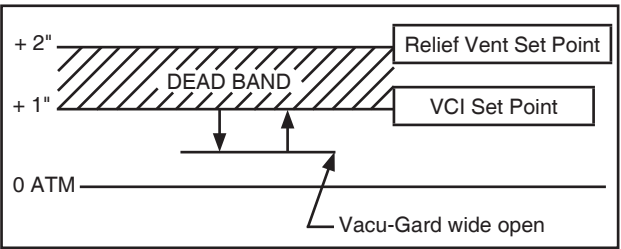

As can be seen from the illustration, the Vacu-Gard gives the greatest dead band between the blanketing valve set point and the relief vent set point.

TABLE 5					
REQUIREMENTS FOR THERMAL INBREATHING - ENGLISH UNITS (Air)					
(Column 1)		(Column 2)	(Column 1)		(Column 2)
TANK CAPACITY		INBREATHING	TANK CAPACITY		INBREATHING
Barrels	Gallons	SCFH	Barrels	Gallons	SCFH
60	2,500	60	35,000	1,470,000	31,000
100	4,200	100	40,000	1,680,000	34,000
500	21,000	500	45,000	1,890,000	37,000
1,000	42,000	1,000	50,000	2,100,000	40,000
2,000	84,000	2,000	60,000	2,520,000	44,000
3,000	126,000	3,000	70,000	2,940,000	48,000
4,000	168,000	4,000	80,000	3,360,000	52,000
5,000	210,000	5,000	90,000	3,780,000	56,000
10,000	420,000	10,000	100,000	4,200,000	60,000
15,000	630,000	15,000	120,000	5,040,000	68,000
20,000	840,000	20,000	140,000	5,880,000	75,000
25,000	1,050,000	24,000	160,000	6,720,000	82,000
30,000	1,260,000	28,000	180,000	7,560,000	90,000

**NOTE:** Table and sizing from API 2000 Seventh Edition, annex A, March 2014.

TABLE 5A			
REQUIREMENTS FOR THERMAL INBREATHING - METRIC UNITS (Air)			
(Column 1)	(Column 2)	(Column 1)	(Column 2)
TANK CAPACITY	INBREATHING	TANK CAPACITY	INBREATHING
CUBIC METERS	Nm <sup>3</sup> /H	CUBIC METERS	Nm <sup>3</sup> /H
10	1.69	5000	787
20	3.37	6000	896
100	16.9	7000	1003
200	33.7	8000	1077
300	50.6	9000	1136
500	84.3	10000	1210
700	118	12000	1345
1000	169	14000	1480
1500	253	16000	1615
2000	337	18000	1745
3000	506	20000	1877
3180	536	25000	2179
4000	647	30000	2495

**NOTE:** Table and sizing from API 2000 Seventh Edition, annex A, March 2014.

TABLE 6				
TANK BLANKETING VALVE CAPACITIES				
INLET PRESSURE psig (Barg)	CAPACITIES IN SCFH (Nm <sup>3</sup> /h)			
	AIR		NITROGEN	
	1" Size	2" Size	1" Size	2" Size
20 (1.4)	13,188 (353)	57,186 (1533)	13,422 (359)	58,192 (1559)
30 (2.1)	16,990 (455)	73,666 (1974)	17,290 (463)	74,962 (2009)
40 (2.8)	20,790 (557)	90,146 (2416)	21158 (567)	91,732 (2458)
50 (3.4)	24,590 (659)	106,626 (2858)	25,026 (670)	108,502 (2907)
60 (4.1)	28,390 (761)	123,106 (3299)	28,894 (774)	125,272 (3357)
70 (4.8)	32,190 (863)	139,586 (3741)	32,762 (878)	142,042 (3806)
80 (5.5)	35,990 (965)	156,066 (4183)	36,630 (981)	158,812 (4256)
90 (6.2)	39,790 (1066)	172,546 (4624)	40,498 (1085)	175,582 (4705)
100 (6.9)	43,590 (1168)	189,026 (5066)	44,366 (1189)	192,352 (5155)
110 (7.6)	47,390 (1270)	205,506 (5508)	48,234 (1292)	209,122 (5604)
120 (8.3)	51,190 (1372)	221,986 (5949)	52,102 (1396)	225,892 (6054)
130 (9.0)	54,990 (1474)	238,466 (6391)	55,970 (1499)	242,662 (6503)
140 (9.6)	58,790 (1576)	254,949 (6833)	59,838 (1603)	259,432 (6952)
150 (10.3)	62,590 (1677)	271,426 (7274)	63,706 (1707)	276,202 (7402)
160 (11.0)	66,390 (1779)	287,906 (7716)	67,574 (1811)	292,972 (7851)
170 (11.7)	70,190 (1881)	304,386 (8158)	71,442 (1914)	309,742 (8301)
180 (12.4)	73,990 (1983)	320,866 (8599)	75,310 (2018)	326,512 (8750)
190 (13.1)	77,790 (2085)	337,346 (9041)	79,178 (2122)	343,282 (9200)
200 (13.8)	81,590 (2187)	353,826 (9483)	83,046 (2225)	360,052 (9649)

**NOTE:** To reduce flow capacity, use the flows plugs listed in Table 2. Reduced capacity will equal the flow plug percentage times the full flow capacity listed above.

# 1" Model 1078 DIMENSIONS

RF FLANGES	A	B	C	D
1" - 150# Integral	5.39" (136.9 mm)	3.07" (78.0 mm)	9.88" (250.9 mm)	3.69" (93.7 mm)
1" - 300# Weldneck	5.64" (143.3 mm)	3.32" (84.3 mm)	10.38" (263.6 mm)	3.94" (100.0 mm)

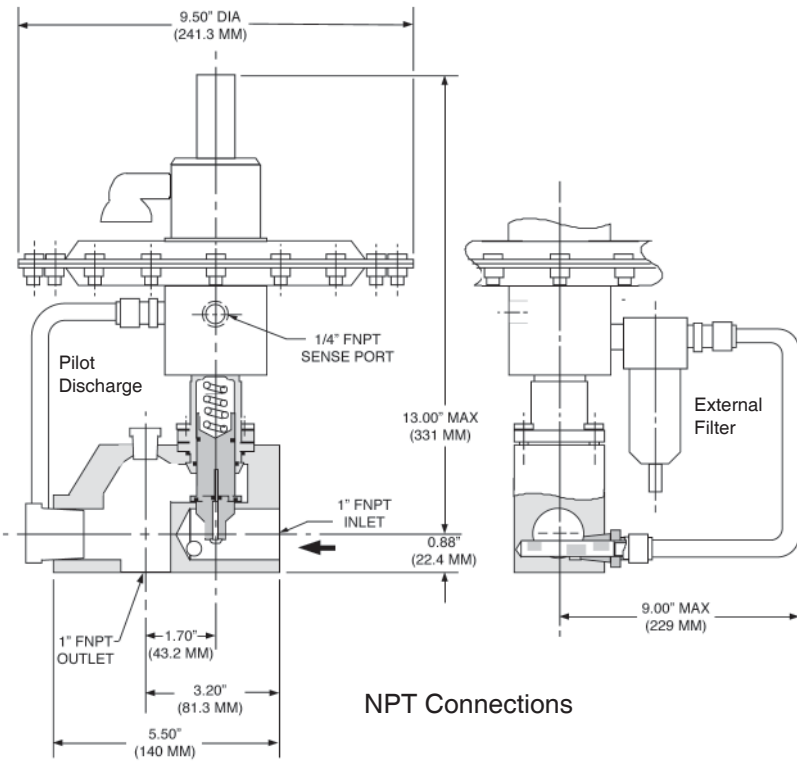

**Approximate Weight**

FNPT:  
18 lbs (8.2 kg)

Flanged:  
23 lbs (10.5 kg)

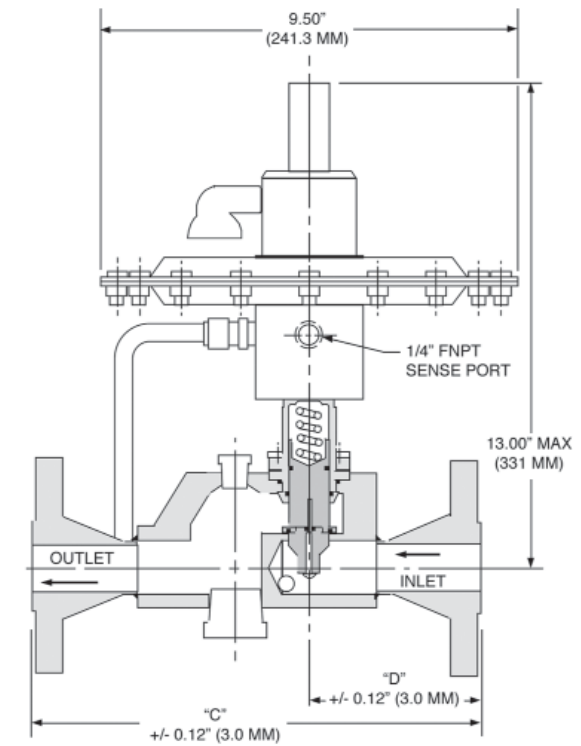
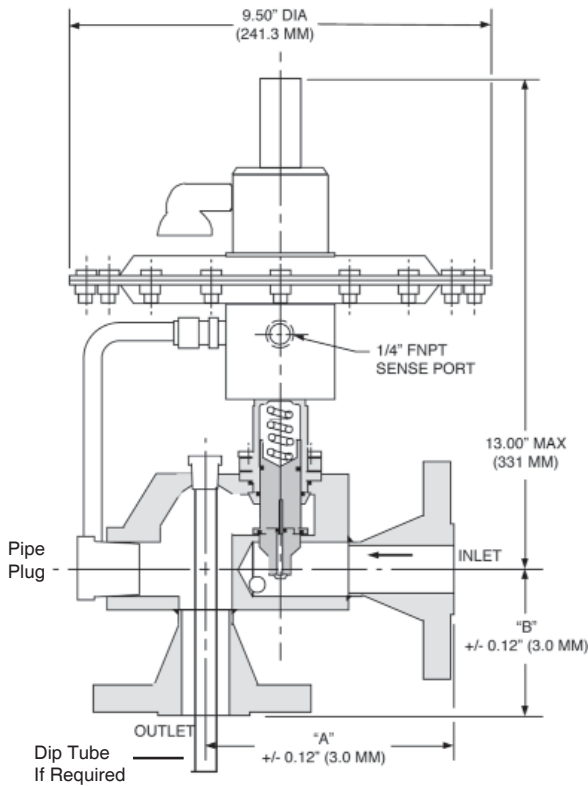



**1" Model 1078 DIMENSIONS (cont.)**

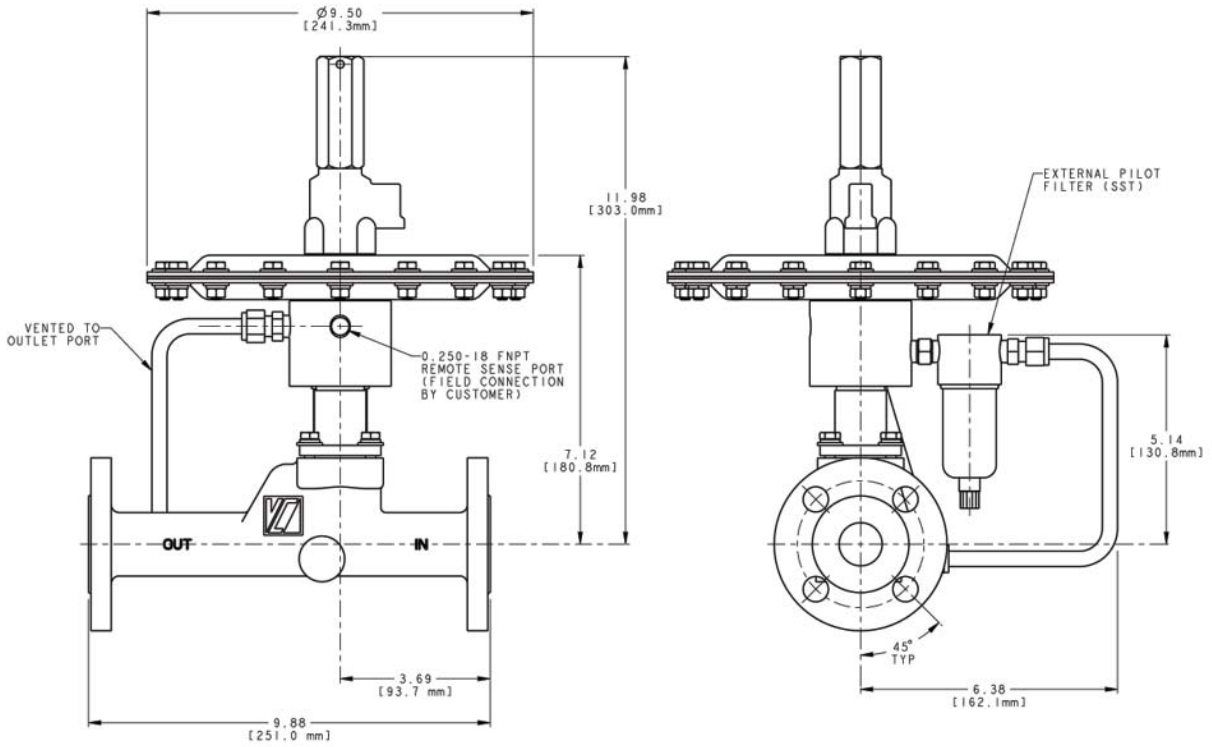

Horizontal (Outlet), Integral 150# RF Flange Body

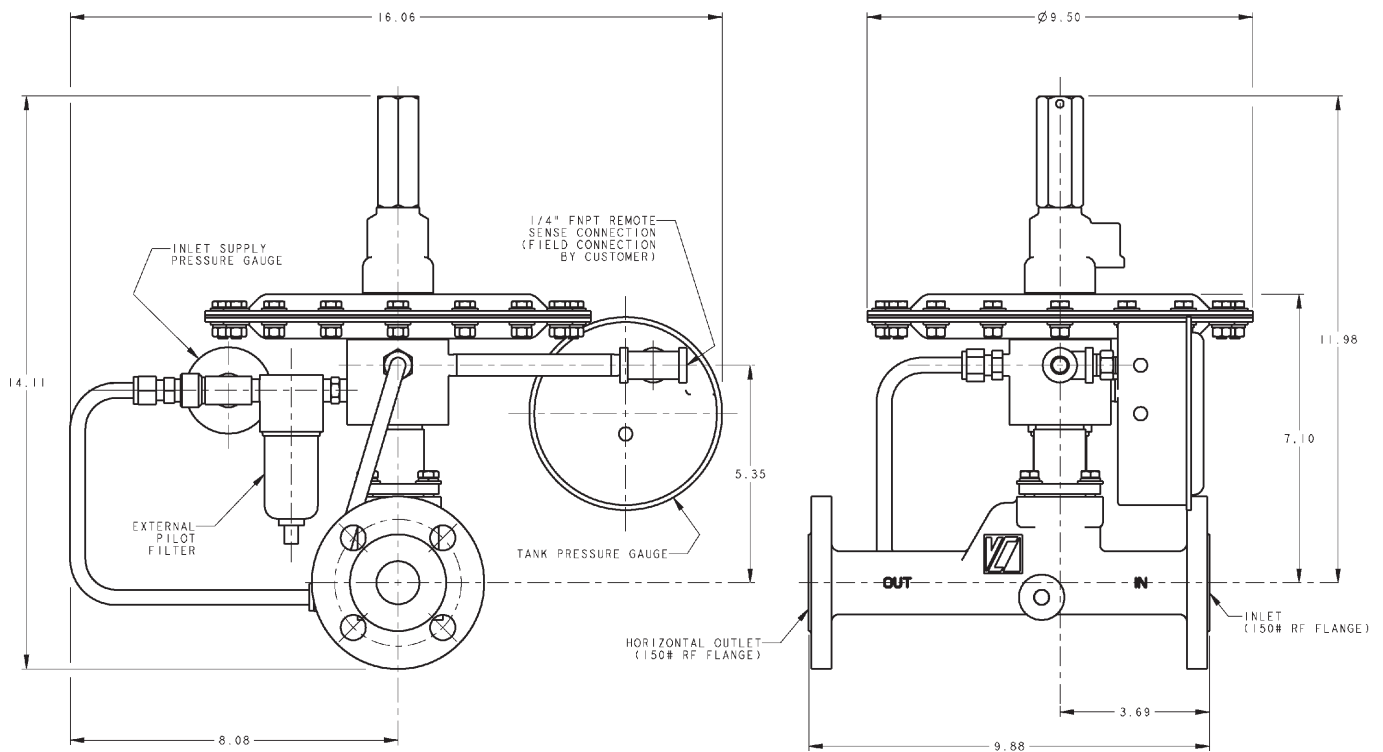

Integral 150# RF Flange Body with Tank and Pressure Gauges

**1" Model 1078 DIMENSIONS (cont.)**

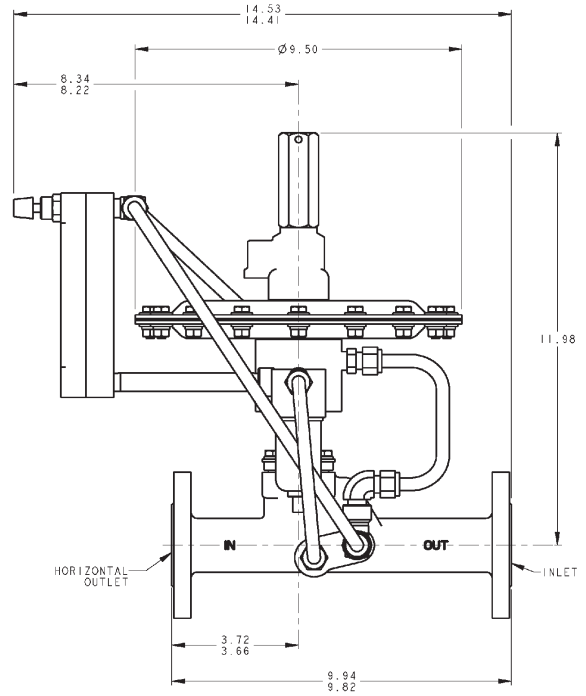
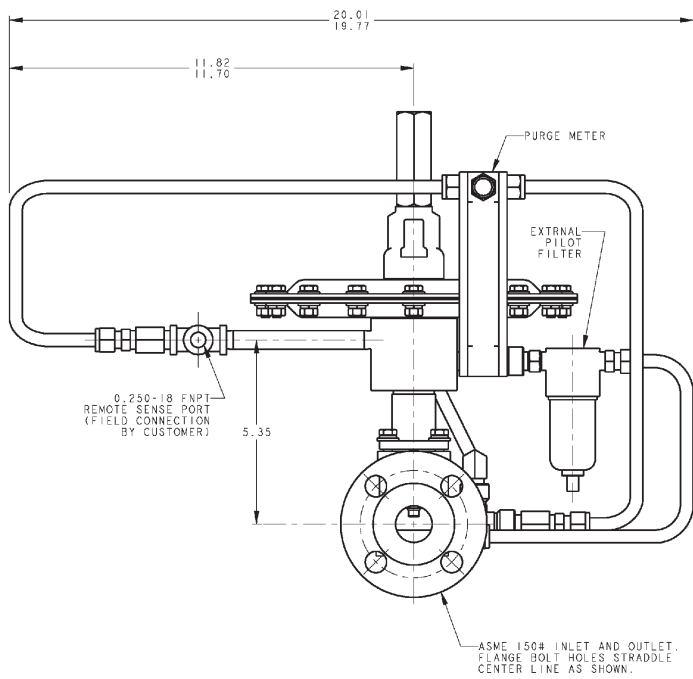

**Integral 150# RF Flange Body with Purge Meter**

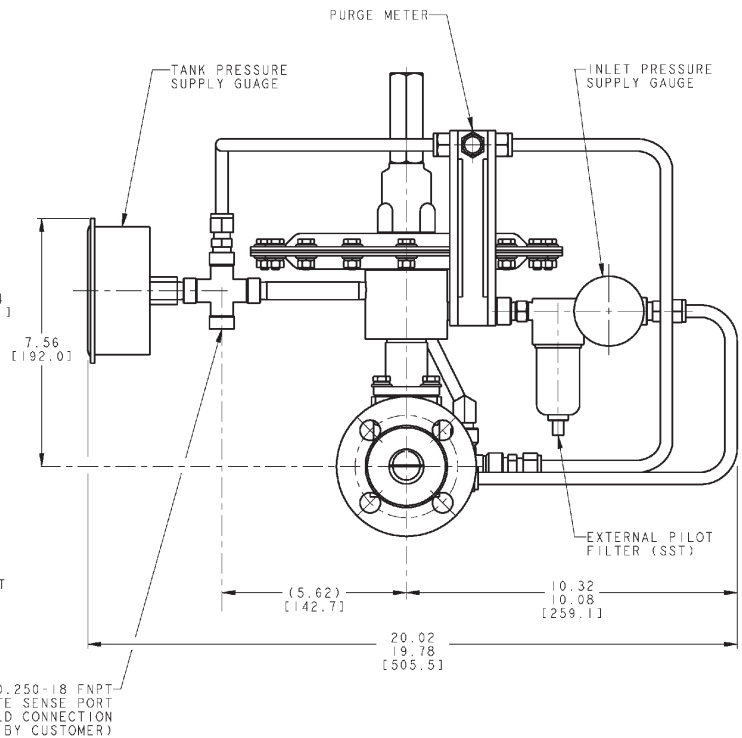
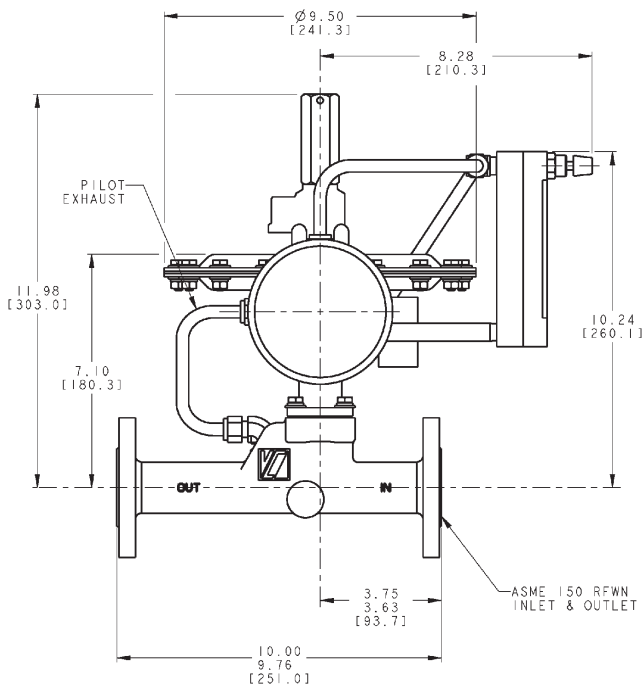

**Integral 150# RF Flange Body with Gauges and Purge Meter**

## 2" Model 1078 DIMENSIONS

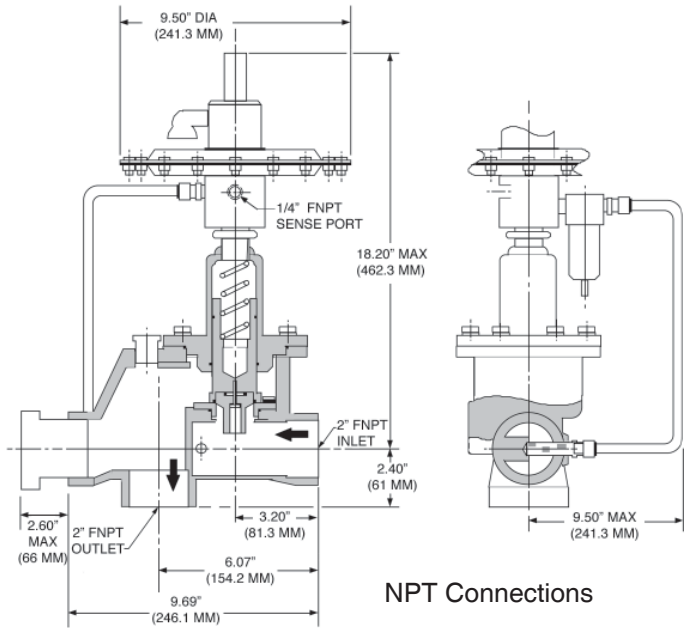

NPT Connections

RF FLANGES	A	B
2" - 150# Weldneck	8.57" (217.6 mm)	4.90" (124.5 mm)
2" - 300# Weldneck	8.82" (224.0 mm)	5.15" (130.8 mm)

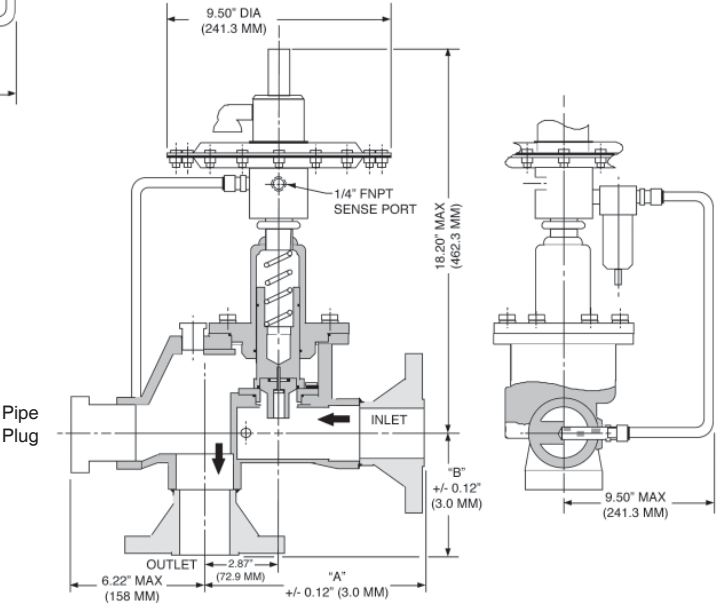

Vertical (Outlet), Weldneck RF Flange

**Approximate Weight**  
FNPT:  
 43 lbs (20 kg)  
  
Flanged:  
 55 lbs (25 kg)

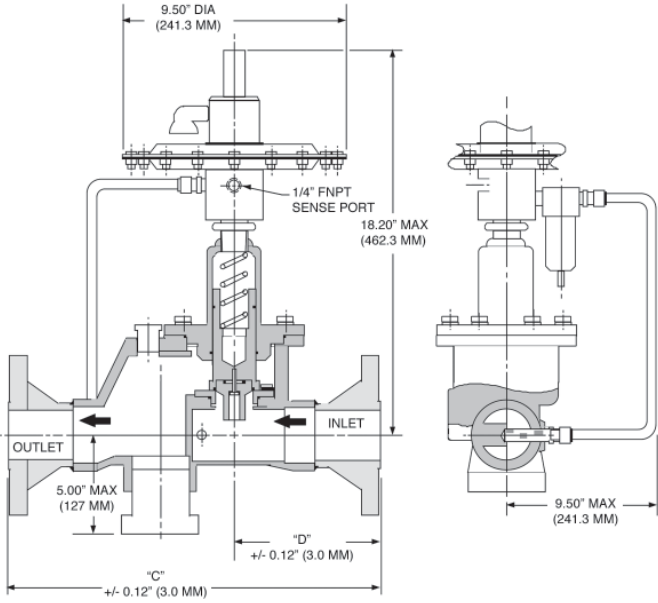

Horizontal (Outlet), Weldneck RF Flange

RF FLANGES	C	D
2" - 150# Weldneck	14.69" (373.1 mm)	5.70" (144.8 mm)
2" - 300# Weldneck	15.19" (385.8 mm)	5.95" (151.1 mm)

## OPTIONAL FEATURES & ACCESSORIES

### Supply Pressure Gauge

To provide local indication of supply pressure.

- Standard ABS gauge with SST fitting.
- Stainless gauge with SST fitting.

### Control Pressure Gauge

To provide local indication of actual tank pressure.

- Standard Magnehelic® gauge with SST fitting.
- Stainless gauge with SST fitting.

### Purge

A purge is used to prevent tank vapors from entering into the valve, specifically the pilot. One Variable Area Flow meter (Rotameter) is used to purge both the sense line and the outlet. The combined flow is 1 - 1.5 SCFH. VCI advises the use of a purge when tank vapors may solidify or crystallize when cooled to ambient temperature.

A purge will also extend the service life of the valve if 316 SST is not compatible with the tank vapors.

- Standard Rotameter used has a 316 SST body with glass tube.

### Sense with Dip Tube (patented) PV-Gard Manifold

The PV-Manifold allows for a very compact installation of a blanketing valve and vent valve on one single tank nozzle. Normally, an installation of this type requires at least three different nozzles; one for the blanketing valve, one for the vent valve, and one for the remote sensing for the blanketing valve. Using the PV-Manifold, only one tank nozzle is required.

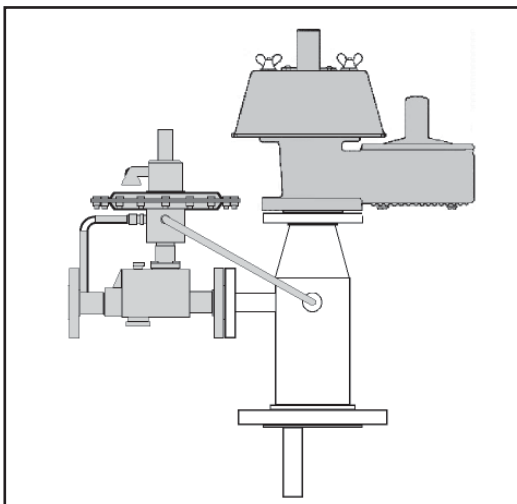

This option provides a sense connection into the tank through the **vertical outlet** of the valve. This can be useful when no tank connection is available for the standard external sense.

- The dip tube length should be sized so that it protrudes 6" to 8" below the tank roof into the tank.
- The dip tube diameter is 0.375" (9.52 mm).
- Standard material is 316 SST.

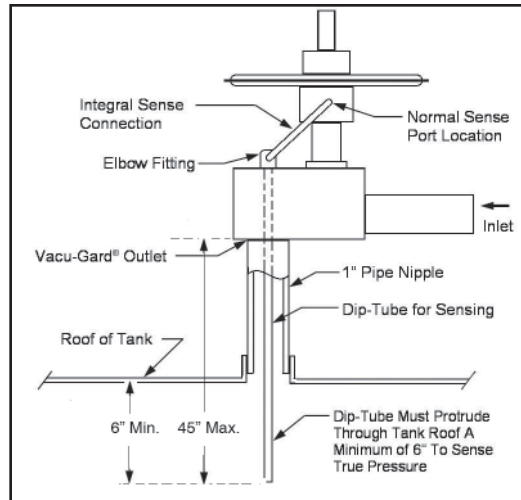

**NOTE: Customer must specify length of Dip Tube.**

### Inline Filter

The valve comes standard with a pre-filter and a pilot filter in the pilot supply line. Therefore the use of an in-line filter is not required for regular blanketing gases. An in-line strainer or filter can be provided on request.

**Option -40: NACE CONSTRUCTION.** Internal wetted portions meet NACE standard MR0175, when exterior of the vent is not directly exposed to a sour gas environment, buried, insulated or otherwise denied direct atmospheric exposure. SST body and Trim - Buna-N or FKM Seat and Seal materials only. NPT or Flanged Connection. (Flanged version requires post-weld stress relieving by heat treating.) SST external Filter with or without purge meter.

**Option -950S: OFFSHORE installations.** Coating of all exterior surfaces will be per Cashco Paint Specs #S-1777 epoxy. Tubing, fasteners, seat surfaces - corrosion resistant parts excluded. Painting of tubing and fasteners optional upon special request.

The contents of this publication are presented for informational purposes only, and while every effort has been made to ensure their accuracy, they are not to be construed as warranties or guarantees, express or implied, regarding the products or services described herein or their use or applicability. We reserve the right to modify or improve the designs or specifications of such product at any time without notice. Cashco, Inc. does not assume responsibility for the selection, use or maintenance of any product. Responsibility for proper selection, use and maintenance of any Cashco, Inc. product remains solely with the purchaser.

**Model 1078 PRODUCT CODE** 02/10/16  
**PILOT OPERATED VACU-GARD®**

Last 6 Characters reserved for SPQ drawing numbers assigned by Cashco Inc.  
 (Format as - # # # # #)

**P** POS 2 POS 3 POS 4 POS 5 POS 6 POS 7 POS 8 POS 9 POS 10 POS 11 **B 0 0 0 0 0 0**

POSITION 2 SIZES		POSITION 3 - OUTLET		POSITION 4 - Product Classification Under European "Pressure Equipment Directive"			POSITION 5 - MATERIALS		
Size	CODE	Outlet	CODE	PRODUCT DESTINATION	HAZARD CATEGORY	CODE	Body/Trim/Diaphragm Case Material	CODE	
1"	1	Horizontal Remote Sensing	J	Anywhere except Europe	N/A	0	1" Only - SST Body w/SST Trim & CS Diaphragm Cases 2" Only - CS Body w/SST Trim & CS Diaphragm Case With SST Fittings & Tubing <sup>1</sup> ( <b>Standard Steel Gauges</b> ) (Recommend Aluminum Pilot Filter from Position 11)	C	
2"	2	Vertical Remote Sensing	R	European Countries * (CE Mark does not apply to DN25 and below)	Sound Engineering Practice (SEP)	S	1" Only - SST Body w/SST Trim & CS Diaphragm Cases 2" Only - CS Body w/SST Trim & CS Diaphragm Case With SST Fittings & Tubing <sup>2</sup> ( <b>Special SST Gauges</b> ) (Recommend Aluminum Pilot Filter from Position 11)	D	
		Vertical Integral Dip-Tube	W		CE Marked Hazard Cat I or II	E	Hastelloy C <sup>®</sup> Body & Trim: CS Upper Diaphragm Case (Select Hastelloy Pilot Filter from Position 11)	H	
		<b>Must indicate length of dip tube in Special Instructions on Order Entry Transmittal Form &amp; on Customer PO.</b> See page 11 of TB			ATEX	A	SST Body, Trim, Diaphragm Case, Fittings & Tubing <sup>2</sup> (Select SST Pilot Filter from Position 11)	S	
				* For products to be placed in service in Europe. Ref to Directive 97/23/EC. Forward Completed "EU" Application Recorder prior to quotation. (Without Recorder- Processing of Purchase Order will be delayed). Contact Cashco for Assistance.			SST Body w/ SST Trim, CS Upper Diaphragm Case, All Wetted Surface, Fittings & Tubing SST <sup>2</sup> (Select SST Pilot Filter from Position 11)		W
							<sup>1</sup> When Steel Gauge(s) required, select pressure range(s) from Position 6. <sup>2</sup> When SST Gauge(s) required, select pressure range(s) from Position 6.		

POSITION 6 - GAUGE OPTION								CODE
No Gauges								0
Supply Gauge Pressure Range psig (Barg)	Supply Gauge ONLY	Supply Pressure Gauge plus Tank Gauge for Low Pressure Range						
		0 - 5"wc (0 - 15 mbar)	0 - 10"wc (0 - 25 mbar)	0 - 15"wc (0 - 40 mbar)	0 - 1psig (0 - 80 mbar)	0 - 5psig (0 - 350 mbar)	0 - 15psig (0 - 1.03 barg)	0 - 20psig (0 - 2 barg)
	CODE	CODE	CODE	CODE	CODE	CODE	CODE	CODE
0 - 100 (0 - 6.9)	1	A	D	G	K	N	S	W
0 - 160 (0 - 11.0)	2	B	E	H	L	P	T	Y
0 - 200 (0 - 13.8)	3	C	F	J	M	R	V	#
NO Supply Gauge	4	5	6	7	8	9	Z	

NOTE: Hastelloy Gauges are not available.

POSITION 7 - End Connections		
End Connections (Flanges are Weldneck Design Unless Stated Otherwise)	1" Body size (P1) only	2" Body size (P2) only
	CODE	CODE
FNPT Connection	T	T
150# RF Threaded Flgs w / nipples	A	A
300# RF Threaded Flgs w / nipples	B	-
150# RF Flgs ( 1" body size has integral flanges)	D	D
300# RF Flgs	E	E
1-1/2" 150# RF Reducing Flgs	K	-
1-1/2" 300# RF Reducing Flgs	J	-
2" 150# RF Reducing Flgs	F	-
2" 300# RF Reducing Flgs	G	-
FNPT Inlet w/1" 150# RF Threaded Flange attached w/Nipple on Outlet	L	-
DN25 / PN40 Flgs	M	-
DN50 / PN16 Flgs	-	P
DN50 / PN40 Flgs	-	R
DN50 / PN40 Reducing Flgs	S	-

POSITION 8 - FLOW PLUG SIZES			
1" Size	CODE	2" Size	CODE
10%	1	20%	D
25%	2	40%	4
50%	5	60%	6
75%	7	80%	8
100%	C	100%	C

POSITION 9 - SEATS & SEALS	
Material	CODE
Buna-N *	B
FFKM 1	C
EPDM	E
FFKM 2	K
FKM (std) *	V

\* Use with NACE Construction.

POSITION 10 - RANGE SPRINGS	
Spring Range	CODE
0.50" - 5.0" wc (1.24-12.4 mbar) **	3
5" - 14" wc (12.4-34.8 mbar)	6
14" - 30" wc (34.8-74.7 mbar)	7
1 - 1.5 psig (69-103 mbar)	8
1.5 - 3 psig (103-207 mbar)	9
3 - 14 psig (0.2-0.96 bar)	H
0" - 1.5" wc vac (0-3.7 mbar) *	A
1.5" - 6" wc vac (3.7-14.8 mbar) *	C

\* SST Tank gauge is not available for these ranges  
 \*\* 0.50" - 0.70" w.c.(1.24 - 1.8 mbar) not available in 2". See Table 4.

POSITION 11 - EXTERNAL PILOT FILTER / OPTION		
Description	Std. Paint	Opt-950S
	CODE	
SST Filter w/Purge	A	6
NACE Const. SST Filter w/Purge	F	7
Special Aluminum Filter (UCC/Dow)	B	-
Alum/Zinc Filter w/Check Valve	C	-
Alum/Zinc Filter w/Check Valve & Purge	M	-
SST Filter w/Check Valve	D	8
Opt-40 NACE Const. SST Filter w/Check Valve	2	9
SST Filter w/Check Valve & Purge	L	G
Opt-40 NACE Const. SST Filter w/Check Valve & Purge	3	J
Alum/Zinc Filter w/Purge	P	-
SST Filter	S	T
NACE Const. SST Filter	E	U
Alum/Zinc Filter	W	-
Hastelloy Screen (Filter)	H	-

Cashco, Inc.  
 P.O. Box 6  
 Ellsworth, KS 67439-0006  
 PH (785) 472-4461  
 Fax. # (785) 472-3539  
 www.cashco.com  
 email: sales@cashco.com  
 Printed in U.S.A. 1078-TB

Cashco GmbH  
 Handwerkerstrasse 15  
 15366 Hoppegarten, Germany  
 PH +49 3342 30968 0  
 Fax. No. +49 3342 30968 29  
 www.cashco.com  
 email: germany@cashco.com

Cashco do Brasil, Ltda.  
 Al.Venus, 340  
 Indaiatuba - Sao Paulo, Brazil  
 PH +55 11 99677 7177  
 Fax. No.  
 www.cashco.com  
 email: brazil@cashco.com