

MSS

This economical split seal installs easily on mixers, reactors, and other containment vessels. On older equipment, or where compression packing is being changed out for a mechanical seal, shaft wobble and eccentricities can be severe. The MSS seal was designed to work in these tough conditions where stuffing box face run-out, bore run-out, and O.D. run-out are beyond the capabilities of seals designed primarily for centrifugal pumps.

Features/Benefits

- Handles shaft run-out up to 0.150" T.I.R.
- The outside seal arrangement of the MSS makes installation, inspection and maintenance simple. Installation time is typically less than 45 minutes - with ten simple steps and common hand tools.
- Nonmetallic wetted parts - the only components of the MSS seal which contact process fluids (or gasses) are the seal faces, insert mounting and shaft packing O-rings.
- Fits in tight spaces with no equipment tear down - can be installed in cramped stuffing box areas where the bearing housing, gear box and/or coupling create obstructions.
- Can be run dry or wet - the self-lubricating faces and a design that dissipates heat from the seal faces, make dry-running the MSS a practical alternative to packings and liquid-running seals on top entry mixers. The MSS can run with wet faces and is a good choice for side entry reactors and paper stock chests.
- Withstands pressure reversals - the MSS design compensates for pressure reversals and helps to ensure product purity.

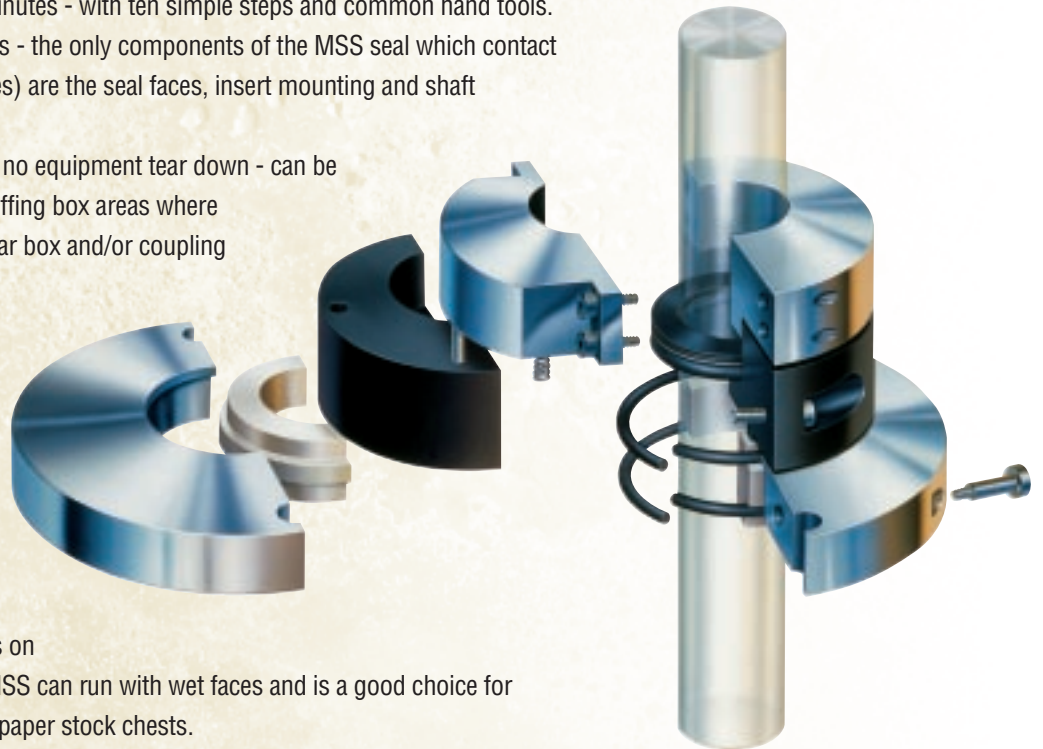

*BW Seals
Durametallic Seals
Pacific Wietz Seals
Pac-Seal*

Materials of Construction

- Seal ring: Carbon
- Insert: Ceramic (tungsten carbide optional)
- Gland and collar: 316 Stainless Steel
- Elastomers: Fluoroelastomer (EPR optional)

Operating Parameters

- Pressures: Dry: Full vacuum up to 75 psi (5 bar)
Wet: Up to 100 psi (7 bar)
- Speeds: Dry: Up to 350 rpm
Wet: Up to 1750 rpm
- Temperatures: Up to 250°F (121°C)
- Shaft Run-out: Up to 0.150" (4mm) T.I.R. (sum total of run-out, eccentricity, and deflection)
- Sizes: 1.000" to 12.000" (25mm to 305mm)

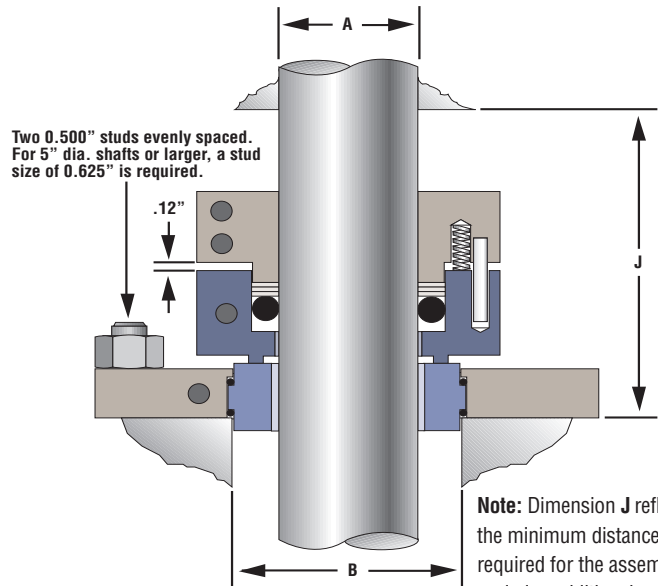

Dimensional Data (dimensions in inches)

Shaft Size ±0.001" (Dimension A)	Standard Bore Diameter ±0.005" (Dimension B)	Gland Bolt Circle Diameter	Distance to First Obstruction (Dimension J)
1.000	2.250	4.75	4.44
1.250	2.500	5.00	4.44
1.500	2.750	5.25	4.44
1.750	3.000	5.50	4.44
2.000	3.250	5.75	4.44
2.250	3.500	6.00	4.44
2.500	3.750	6.25	4.44
2.750	4.000	6.50	4.44
3.000	4.250	6.75	4.44
3.250	4.500	7.00	4.44
3.500	4.750	7.25	4.44
3.750	5.000	7.50	4.44
4.000	5.250	7.75	4.44
4.250	5.500	8.00	4.44
4.500	5.750	8.25	4.44
4.750	6.000	8.50	4.44
5.000	6.500	9.50	5.00
5.250	6.750	9.75	5.00
5.500	7.000	10.00	5.00
5.750	7.250	10.25	5.00
6.000	7.500	10.50	5.00

The above is a partial listing. Additional sizes up to 12.000" and metric sizes are also available.

Note: For sizes and conditions not listed, contact your local Flowserve Representative.

The information and specifications presented in this product brochure are believed to be accurate, but are supplied for information purposes only and should not be considered certified or as a guarantee of satisfactory results by reliance thereon. Nothing contained herein is to be construed as a warranty or guarantee, express or implied, with respect to the product. Although Flowserve Corporation can provide general application guidelines, it cannot provide specific information for all possible applications. The purchaser/user must therefore assume the ultimate responsibility for the proper selection, installation, operation and maintenance of Flowserve products. Because Flowserve Corporation is continually improving and upgrading its product design, the specifications, dimensions and information contained herein are subject to change without notice.

Primary Worldwide Flow Solutions Division Locations

Licenseses, authorized agents, and affiliated companies located worldwide.

United States	Canada	Netherlands	Argentina	Australia	
Kalamazoo, MI Phone 616-381-2650 Fax 616-381-8368	Edmonton, Alberta Phone 780-463-7958 Fax 780-450-1241	Scarborough, Ontario Phone 416-292-2877 Fax 416-292-5190	Roosendaal Phone 31-165-581400 Fax 31-165-552622	Villa Martelli Phone 54-11-4790-6800 Fax 54-11-4709-7072	Marayong NSW Phone 61-2-8822-7100 Fax 61-2-9679-7511
Singapore	Mexico	Brazil	Japan	Germany	
Phone 65-746-4318 Fax 65-747-1963	Tlaxcala Phone 52-2-461-6791 Fax 52-2-461-6847	Sao Paulo Phone 55-11-4066-8600 Fax 55-11-4066-7014	Osaka Phone 81-720-85-5571 Fax 81-720-85-5575	Dortmund Phone 49-231-6964-0 Fax 49-231-6964-248	

www.flowserve.com