

ML-200

Dry Gas Dual Cartridge Canister Seal for Mixers and Agitators

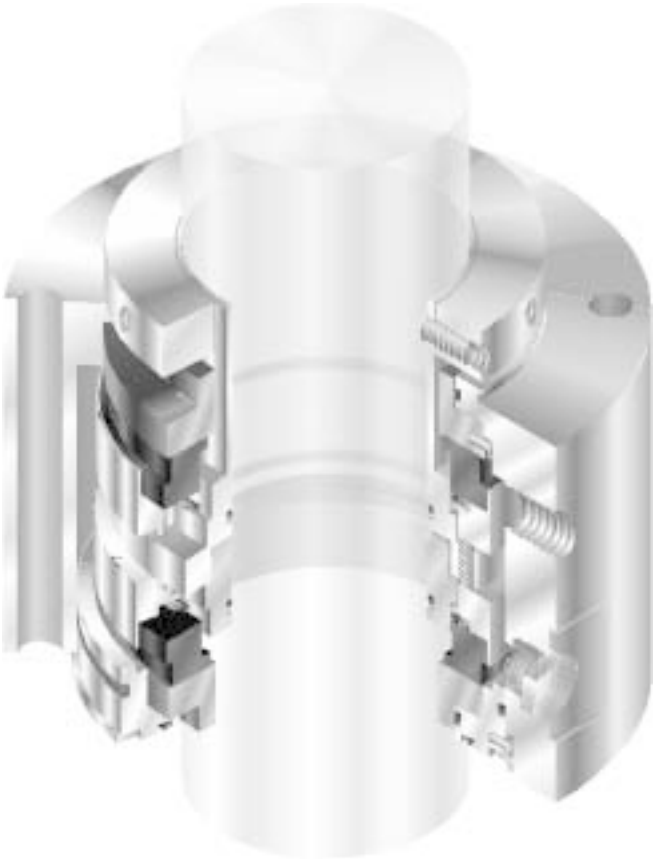

Installation Instructions

Congratulations

You have just purchased a reliable, long-life cartridge canister dual seal product manufactured by the leading manufacturer of sealing systems in the world today. This seal is designed to run as a full fluid film dry gas seal and requires no additional lubrication or liquid flush of the seal faces to operate. With proper installation and operation, this ML-200 seal can be a valuable contribution to your operation by significantly reducing the mean time between planned maintenance (MTBPM) of your rotating mixer or agitator.

1 Equipment Check

- 1.1 **Follow plant safety regulations** prior to equipment disassembly:
 - **Consult** the plant Material Safety Data Sheet (MSDS) files for hazardous material regulation.
 - **Wear** designated personal safety equipment.
 - **Lock out** the mixer or agitator motor and valves to and from the vessel.
 - **Relieve** any pressure in the vessel.
 - Use plant **vessel entry procedures** if it is necessary to enter the vessel.
- 1.2 **Secure the mixer or agitator shaft** in accordance with the mixer or agitator manufacturer's instructions.
- 1.3 **Remove the coupling and/or drive** to access the seal area. Follow the manufacturer's instructions.
- 1.4 **Remove the existing seal assembly.**
- 1.5 **Remove all burrs and sharp edges** from the shaft and vessel flange area. The shaft and vessel flange must be free of burrs, sharp edges, cuts, dents, or corrosion that might cause leakage past the sleeve packing O-rings, shown on the assembly drawing as ⑪ and ⑪A, and the vessel flange O-ring gasket.
- 1.6 **Check requirements** for the shaft and the vessel flange. They must agree with the dimensions shown in Figure 1.
- 1.7 **Check the assembly drawing** accompanying the seal assembly for specific seal design data, materials of construction, dimensions, and recommended piping connections.

- 1.8 **Check the shaft O.D., vessel flange bolt size, bolt circle, and distance to the coupling or drive** to ensure that these dimensions agree with the seal assembly drawing provided.
- 1.9 **Handle the seal assembly with care**, it is manufactured to precise tolerances. The sealing faces of the rotors (3) and (3A) and the stators (3B) and (3C) are of special importance. These sealing faces are lapped to rigid specifications required for full fluid film dry gas seals. If it becomes necessary to disassemble the seal, **keep these sealing faces clean and dry at all times** and **protect them from damage** since they are subject to impact fracture.
- 1.10 **Pressure testing** of this cartridge canister dual seal prior to installation is possible using filtered dry nitrogen or instrument air. Consult Flowserve, Flow Solutions Division for acceptable gas leakage rates for this seal design.

Caution Note: Bench test pressure is 50 (3.5 bar) PSI Maximum

Mixer/Agitator Shaft and Flange Requirements Figure 1

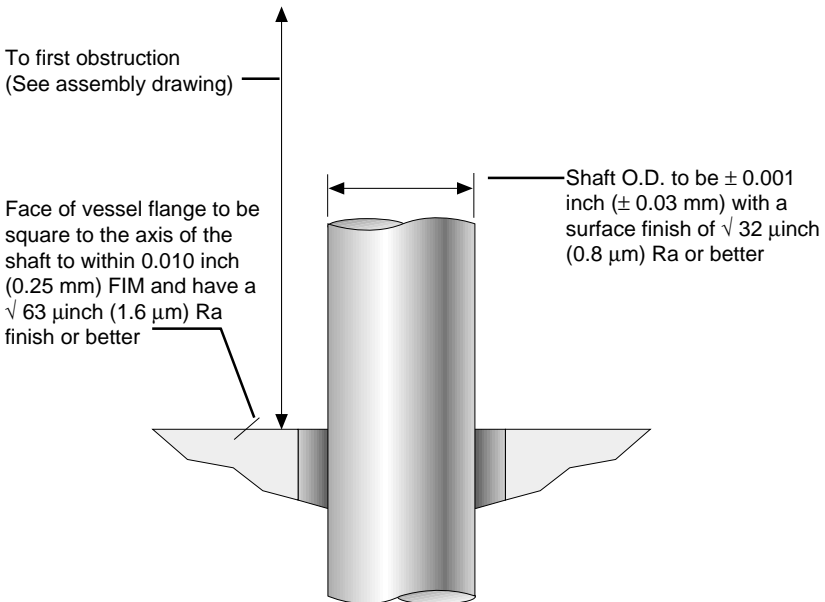

- Bearings, drive, and coupling must be in good condition
- Maximum vertical shaft movement (axial end play) = 0.024 inch (0.61 mm) FIM
- Maximum static vessel flange out of concentricity = 0.020 inch (0.50 mm) FIM
- Maximum static vessel flange to shaft out of squareness = 0.010 inch (0.25 mm) FIM
- Maximum dynamic shaft deflection = 0.125 inch (3 mm) FIM

The ML-200 seal design may include an optional radial bearing in the canister to protect the seal from excessive shaft runout or whip.

2 ML-200 Seal Installation

Tools needed:

Tools provided:

- ***Krytox lubricant** for O-rings and equipment shaft O.D.

Tools not provided:

- **Open end wrenches** to secure housing nuts or bolts
- **Allen wrenches** for housing cap screws
- **Allen wrenches** for seal centering devices and set screws

2.1 **Install the seal adapter plate** on the vessel flange if required.

2.2 **Lightly lubricate the equipment shaft** in the area that the seal sleeve packing O-rings (11) and (11A) will contact the shaft. Use the Krytox lubricant provided if it is compatible with the process fluid. The shaft in the area of the seal sleeve collar set screws (13) must be free of lubricant.

2.3 **Secure the vessel flange O-ring** in the gasket O-ring groove using the Krytox lubricant provided if it is compatible with the process fluid.

2.4 **Install the ML-200 seal onto the equipment shaft** with the end containing the centering tabs (CT) or retaining plates (15) toward the equipment drive end and position the seal assembly onto the vessel flange. Use the lifting eyes supplied to gently lower the canister assembly onto the adapter plate. Do not bolt the canister seal assembly to the adapter plate or vessel flange at this time. Care should be exercised when passing the seal sleeve (10) incorporating the sleeve packing O-rings (11) and (11A) over any keyways or threads that may be present. Any steps or shoulders on the equipment shaft should be beveled to prevent damage (pinching and cutting) of these sleeve packing O-rings during installation.

2.5 **Position the canister seal assembly** so that the barrier gas ports and any optional bearing lubrication fittings are easily accessible.

2.6 **Reinstall the shaft coupling and/or drive. Remove any shaft holding or restraining clamps** and complete adjustments so that the shaft is in its final operating position.

2.7 **Install and tighten the vessel flange studs or cap screws** to secure the canister seal assembly to the vessel flange or adapter plate. Do not over tighten.

- 2.8 **Tighten the set screws (13)** in the sleeve collar (9) uniformly with an Allen wrench.
- 2.9 **Remove the centering tabs (CT) or retaining plates (15).** **Save the centering tabs or retaining plates and attachment hardware** for future use.

3 Dry Gas Supply

The ML-200 seal design is engineered to operate with a dry filtered (5 micron) gas supplied to the seal chamber at a consistent pressure 50 psig (3.5 bar) above the maximum operating vessel pressure. No liquid barrier or flush is required to lubricate these special seal faces. Dry nitrogen gas is the barrier fluid of choice. However, dry instrument air may be used in compatible applications. The dry gas to be used, maximum vessel pressure, shaft speed, temperature, equipment, and shaft size must be specified when the seal is ordered. Do not attempt to use this seal under other conditions without consulting Flowserve, Flow Solutions Division.

4 ML-200 Seal Piping

- 4.1 **Install piping for the clean dry nitrogen** to the canister tap. A pressure regulator, filter, metering valve, flow meter, check valve, low pressure alarm, and pressure gauge are recommended. See Figure 2.
- 4.2 Bearings (optional) have been pre-lubricated during seal assembly.

Recommended Piping for Dual Dry Gas Seal

Figure 2

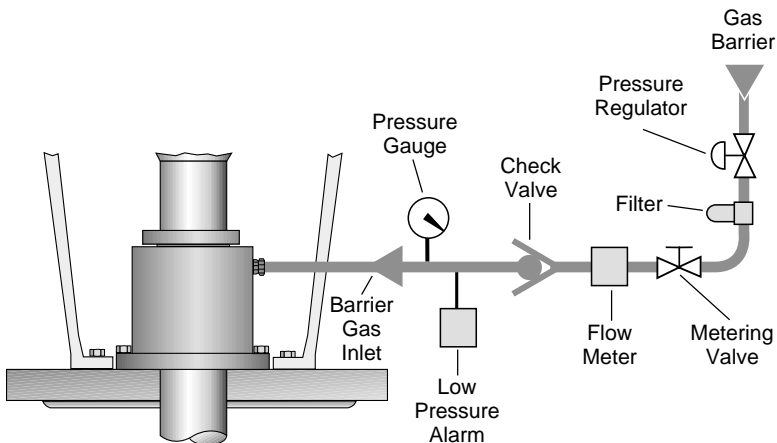

5 Seal Operation

To assure reliable operation of this sealing product, the following operating guidelines should be observed.

- 5.1 **Maintain the dry gas supply pressure** both while the seal is operating and when the equipment is on standby. Always ensure that there is an adequate flow of barrier gas to the seal.
- 5.2 **Do not exceed the maximum barrier pressure** specified for the seal design. The barrier pressure should be 50 psig (3.5 bar) above the operating vessel pressure.
- 5.3 **Do not exceed the maximum vessel pressure** specified for the application. This could reduce the recommended vessel to barrier differential pressure which could adversely affect seal performance.
- 5.4 **Do not exceed the maximum vessel temperature** specified for the application. This could exceed the temperature limits of the seal materials of construction applied to the application.
- 5.5 **Do not exceed the seal material corrosion limits.** This seal was designed for the application shown on the seal assembly drawing. Do not exceed the limits of the material alloys and elastomers supplied in its construction. See Flowserve Publication FTA101, Seal Selection Guide, for chemical resistance ratings.

For any problems encountered during installation and/or operation of this product, contact your nearest Flowserve Sales and Service Representative or Authorized Distributor.

6 Repairs

The ML-200 seal is designed to provide reliable operation under a wide range of operating conditions. However, there will come a time when the seal will fail as it reaches its normal life expectancy or if it is operated outside of its design capabilities.

This product is a precision sealing device. The design and dimensional tolerances are critical to seal performance. Only parts supplied by Flowserve should be used to repair this seal. These parts are available from numerous Flowserve stocking locations. When ordering replacement parts, refer to the part code and B/M number.

If desired an analysis of the seal can lead to recommendations for improving seal MTBPM. Observations concerning seal life, operating conditions, and the condition of the seal itself should be recorded. Flowserve Form AO5.18 provides a helpful guide for seal failure analysis. A spare backup seal should be stocked to reduce equipment down time.

This seal can normally be reconditioned. When repair is necessary, the centering tabs (CT) or retaining plates (15) should be reinstalled and the seal carefully removed from the equipment.

Decontaminate the seal assembly and return it, with centering tabs or retaining plates and shipping plug installed, to Flowserve with an order marked **“Repair or Replace”**. **A signed certificate of decontamination** must be attached. **A Material Safety Data Sheet (MSDS) must be enclosed** for any product that came in contact with the seal. The seal assembly will be inspected and, if repairable, it will be rebuilt, tested, and returned in its original condition.

Some ML-200 design features are covered by USA patent numbers 5,556,111 and 5,370,403 and are patent pending in some foreign countries.

TO REORDER REFER TO

B/M # _____

F.O. _____

All Flowserve Corporation, Flow Solutions Division, products must be installed in accordance with Flowserve installation instructions. Failing to do so or attempting to change or modify Flowserve products will void Flowserve's limited warranty. Flowserve's limited warranty is described fully in Flowserve's Standard Terms and Conditions of Sale. Flowserve makes no warranty of merchantability or fitness for a particular purpose and in no event shall Flowserve be liable for consequential or incidental damages.

Flowserve Corporation

Flow Solutions Division

Primary Worldwide Flow Solutions Division Locations

Licenseses, authorized agents, and affiliated companies located worldwide

United States	Canada	Netherlands	Argentina	Australia	
Kalamazoo, MI Phone 616-381-2650 Fax 616-381-8368	Edmonton, Alberta Phone 780-463-7958 Fax 780-450-1241	Scarborough, Ontario Phone 416-292-2877 Fax 416-292-5190	Roosendaal Phone 31-165-581400 Fax 31-165-552622	Villa Martelli Phone 54-11-4709-6800 Fax 54-11-4709-7072	Marayong NSW Phone 61-2-8822-7100 Fax 61-2-9679-7511
Singapore	Mexico	Brazil	Japan	Germany	
Phone 65-746-4318 Fax 65-747-1963	Tlaxcala Phone 52-2-461-6791 Fax 52-2-461-6847	Sao Paulo Phone 55-11-4066-8600 Fax 55-11-4066-70144	Osaka Phone 81-720-85-5571 Fax 81-720-85-5575	Dortmund Phone 49-231-6964-0 Fax 49-231-6964-248	

www.flowserve.com

Printed in U.S.A.

ISO 9000
Certified

FIS101
REV 03/98 USA