

Pressure / vacuum safety valve BOG type ND 40 to 100



Application

The BOG combined pressure/vacuum safety valve is a safety component. It has a large number of applications in the food, chemical, pharmaceutical, cosmetics and biotechnology industries as well as other sectors requiring sanitary type equipment.

Operating principle

The BOG valve comprises a cylindrical body receiving an arnite customized calibrated valve (down to 2 mbar) on the vacuum side and another arnite valve on the pressure side loaded with a weight to provide a customized calibrated pressure, up to 50 mbar (calibration up to 490 mbars possible using spring). The seal on the seats is provided by special "low pressure" EPDM rings (V-rings).

Standard definition

The vertically assembled BOG valve is connected on its side by a plain 90° inlet to be welded, with or without bend.

We decline it in the following versions :

- P° non collected exhaust/vacuum (BOGA)
- P° collected exhaust/vacuum (BOGB)
- Pressure non collected exhaust (BOGC)
- Pressure collected exhaust (BOGD)
- Vacuum (BOGE)

We recommend a dismountable connection in the tank, depending on customer's standard, and in the collected exhaust, in order to realize easily the maintenance operations.

Materials

Components in contact with the product being conveyed: 1.4404 (316L) stainless steel / arnite FDA.

Other metal components: 1.4306 (304L) stainless steel.

Gaskets in contact with the fluid being conveyed: EPDM.

Finish: semi-bright (medium Ra 0,8 µm).

Sizes

ND40, ND65 & ND100

Technical characteristics

Set pressure using weight: from 2 to 50 kPa (0,002 to 0,05 bar).

Set pressure using spring: from 60 to 500 kPa (0,06 to 0,5 bar).

Set vacuum using weight: from 2 to 50 kPa (0,002 to 0,05 bar).

Set vacuum by external spring: from 60 to 500 kPa (0,06 to 0,5 bar).

In use temperatures: from 0 to + 120°C.

We reserve the right to modify our products without notice, including those for which orders have already been placed.

SERVINOX

7, avenue Georges Politzer - 78197 Trappes cedex - France

Ph. : + 33 (0)1 30 16 15 00 - Fax : +33 (0)1 30 16 15 01

Email : servinox@servinox.com - Web : <http://www.servinox.com>

BOG NM A GB

Pressure / vacuum safety valve BOG type ND 40 to 100

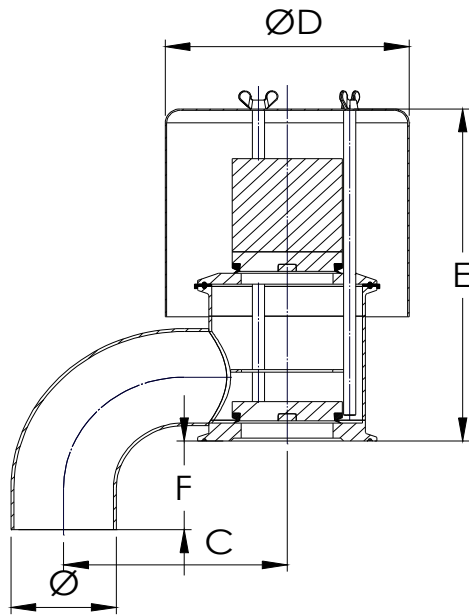

BOGA

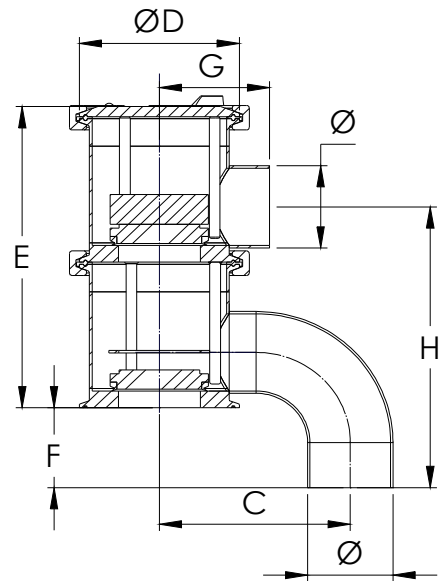

BOGB

Dimensions table (mm)

Sizes	38 mm	40 mm	63,5 mm	65 mm	100 mm
C	115	123	142	148.5	197
D	162	162	162	162	323
E	204	204	239.5	239.5	311
F	26	28.5	62	64	74
Ø	38	40	63.5	70	104

Dimensions table (mm)

Sizes	38 mm	40 mm	63.5 mm	65 mm	100 mm
C	115	123	142	148.5	197
D	91	91	119	119	183
E	203	203	234	234	358
F	26	28.5	62	64	74
G	58	63	82	82	112
H	156	179	218	223	313
Ø	38	40	63.5	70	104

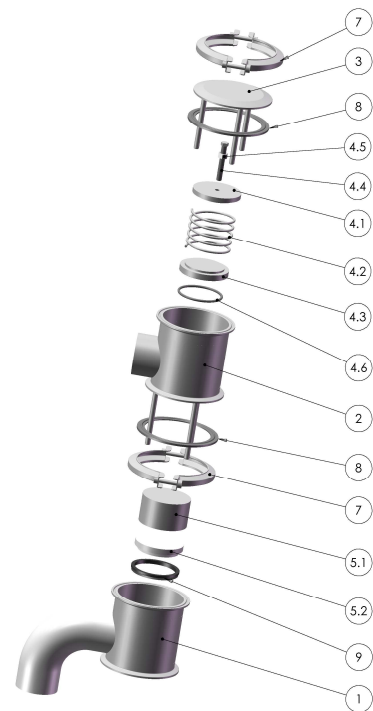
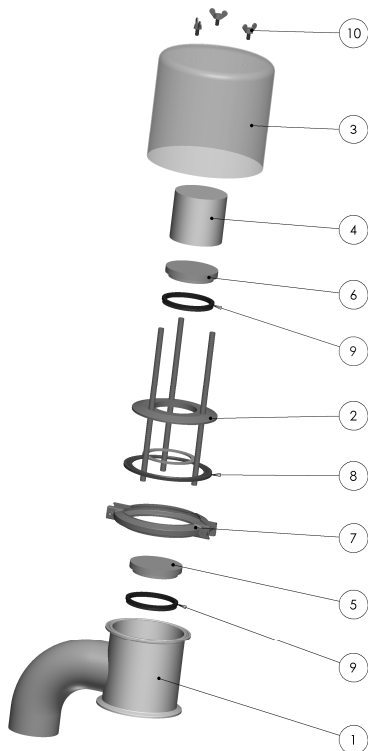

We reserve the right to modify our products without notice, including those for which orders have already been placed.

SERVINOX

7, avenue Georges Politzer - 78197 Trappes cedex - France

Ph. : + 33 (0)1 30 16 15 00 - Fax : +33 (0)1 30 16 15 01

Email : servinox@servinox.com - Web : <http://www.servinox.com>

BOG NM A GB

Pressure / vacuum safety valve BOG type ND 40 to 100

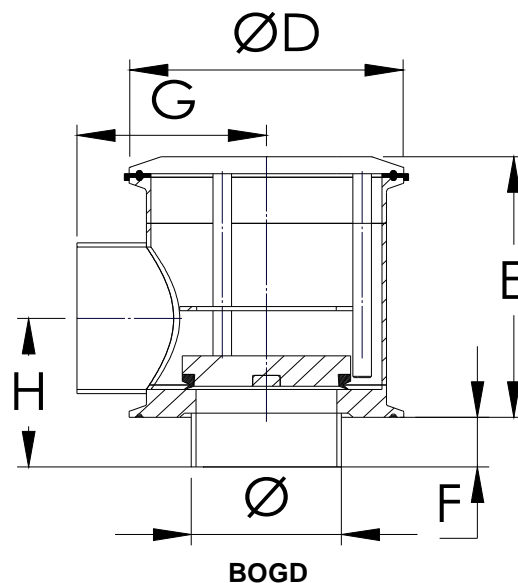
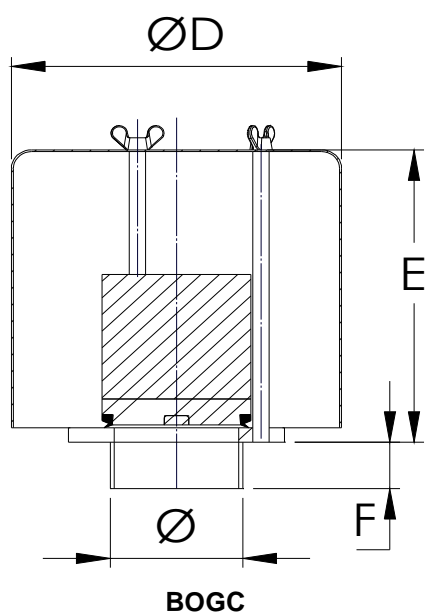

Dimensions table (mm)

Sizes	38 mm	40 mm	63.5 mm	65 mm	100 mm
D	120	120	162	162	323
E	125	125	160	160	192
F	25	25	25	25	25
Ø	38	40	63.5	70	104

Dimensions table (mm)

Sizes	38 mm	40 mm	63.5 mm	65 mm	100 mm
D	102	102	119	119	183
E	123	123	120	120	185
F	25	25	25	25	25
G	63	63	82	82	111
H	56	56.5	68	71	91
Ø	38	40	63.5	70	104

We reserve the right to modify our products without notice, including those for which orders have already been placed.

SERVINOX

7, avenue Georges Politzer - 78197 Trappes cedex - France

Ph. : + 33 (0)1 30 16 15 00 - Fax : +33 (0)1 30 16 15 01

Email : servinox@servinox.com - Web : <http://www.servinox.com>

BOG NM A GB

Pressure / vacuum safety valve BOG type ND 40 to 100

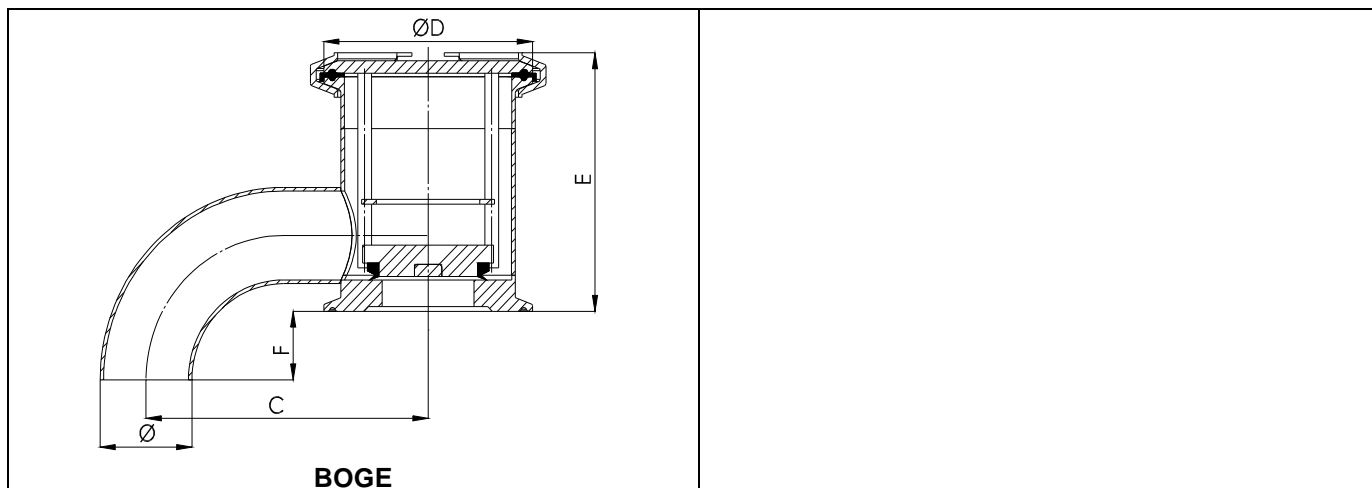

Dimensions sizes (mm)

Sizes	38 mm	40 mm	63,5 mm	65 mm	100 mm
C	115	123	142	148.5	197
D	91	91	119	119	183
E	104	104	120	120	185
F	26	28.5	62	64	74
Ø	38	40	63.5	70	104

Options

- A) Male threaded end, clamp or flange according to requested standard.
- B) Gaskets in Perbunan (nitrile), FPM (VITON equivalent),
- C) Collected exhaust male, clamp or flange according to requested standard.
- D) Anti-insect filter.
- E) CIP pipe.
- F) Higher pressure calibration (max 50kPa / 500mbars)
- G) Detection system on vacuum.
- H) Heating collar
- K) ATEX version, 1 & 2, gas & dust
- Z) Special designs on request.

When ordering, please provide the following information:

- Size,
- Type of connections.
- In-use pressure range.
- Options requested.

Note :

For further details, refer to the BOG valve spare parts catalogue and instruction manual.

CIP pipe option
Mini clamp ND10 inlet



Drip collector & anti-insect filter



Opening detection on vacuum



We reserve the right to modify our products without notice, including those for which orders have already been placed.

SERVINOX

7, avenue Georges Politzer - 78197 Trappes cedex - France
Ph. : + 33 (0)1 30 16 15 00 - Fax : +33 (0)1 30 16 15 01
Email : servinox@servinox.com - Web : <http://www.servinox.com>

BOG NM A GB