



The well proven TC Klinger Magnetic Level Gauge is particularly suitable for duties where dangerous and toxic liquids or gases are involved and where the following features, benefits and options are required:-



- > Immediate and accurate response to level changes, giving clear and sharp legibility.
- > Continuous indication of liquid level.
- > Local and remote display.
- > Point switching facilities.
- > Robust, shockproof and completely sealed for safety.
- > No leakage to atmosphere.
- > Particularly suitable for dangerous or toxic fluids.
- > Ideal for liquid interface applications.
- > Powerful omni-direction magnet system – guide-free float.
- > Display can be rotated through 360° irrespective of float position.
- > Automatic float warning.
- > High pressure capability – up to 200 bar unvented.
- > High temperature capability – standard up to 400°C.
- > Standard SG range 0.4 – 2.2
- > Unlimited length.
- > Top mounted options.
- > PTFE/PFA lined, PP, PVDF and uPVC versions.
- > Simple to engineer and easy to install.
- > Eliminates preventive maintenance.
- > An economical alternative to:- Conventional level gauges and other level measuring systems.
- > Display unit protection IP67.

Design Considerations

Magnetic Level Gauges, depend not only on the integrity of the chamber but also on the float design and the ability to satisfy all design parameters, ie. specific gravity, pressure and temperature, without compromising the magnetic linkage to the display and associated controls. Many competitive systems sacrifice display performance by using smaller and weaker magnet systems to achieve low SG and higher pressures, invariably with detrimental effect. Others use guided and vented floats to achieve the same result, which again can prove limiting and troublesome.

The Advantages Of The System

The system, built on many years experience, has taken all these factors into consideration and designed out these problem areas. This unique system uses a patented ferrite moulded wafer system, which combined with a sealed guide-free float carrying a powerful omni-directional magnet system, provides ultimate performance and reliability, even under the most severe conditions.

Operation

The TC Klinger Magnetic gauge is designed so that the liquid being measured is enclosed within a sealed chamber.

A stainless steel, titanium or plastic float fitted with a permanent omni-directional magnet moves freely inside the chamber and actuates the magnetic wafers within the indicator. As the float rises or falls with the liquid level each wafer rotates 180° and so presents a contrasting colour. Those wafers above the float show white, whilst those level and below show red – the indicator then presents a clearly defined and accurate level of the liquid in the chamber.

The wafers resist accidental disturbance (e.g. vibration) due to their edge magnetisation and mutual attraction.

To complement the range, the Magnetic Gauge can be supplied with Alarm Switches or Transmitter and Controller to remotely display the liquid level.

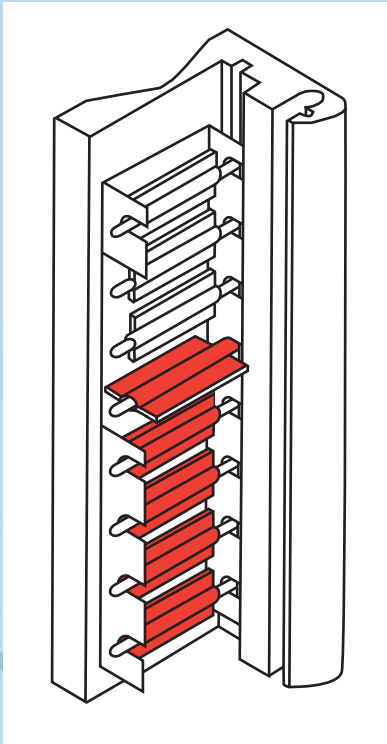
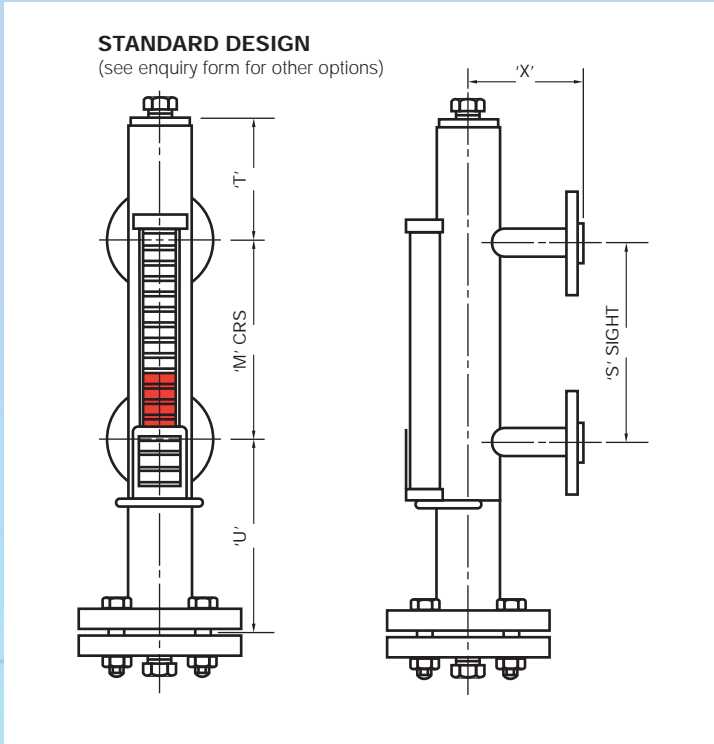

■ **Features and Benefits**

- > **Indicator** Aluminium or Stainless Steel outer housing can be assembled to any length and mounted to suit the best viewing position.
- > **Coloured Wafers** 25mm wide, red and white (or green, red and yellow) remain magnetically locked in the vertical position until disturbed by the greater magnetic force of the float magnet.
- > **Automatic Float Warning** The wafers at the bottom of the indicator are mounted with their colours reversed. Should the float reach that level, they again present a sharp, immediately readable indication of float failure.
- > **Sealed Float** of reinforced stainless steel, titanium or corrosion resistant plastic.
- > **Sealed Chamber** Sealed chamber fabricated from stainless steel tubing, corrosion resistant plastics or other 'exotic' non magnetic metals.
- > **Interface** The gauge is ideally suited for measuring liquid interfaces. Floats are available with a variety of specific gravities to suit the liquids being monitored.
- > **Point Switches** Switches can be fitted on the gauge at any level and so provide signals at high, low and intermediate points.
- > **Transmission and Monitoring for Remote Display** Can be offered as a complete original equipment package or retro-fitted to an existing Magnetic Gauge.
- > **Versatility** The simple concept of the Magnetic Gauge allows for flexible design to adapt to a variety of installation needs. Gauges can be manufactured to an almost unlimited length and in any configuration.

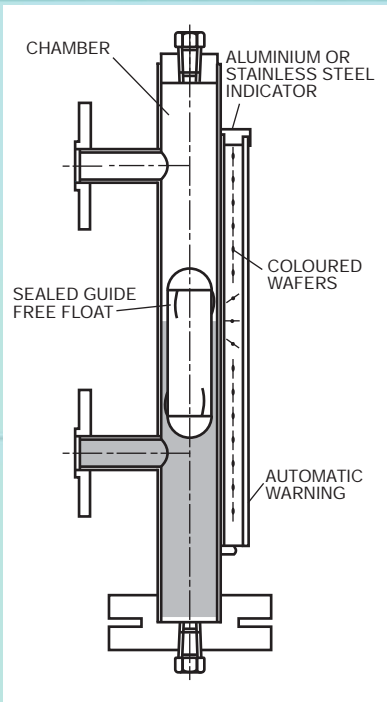
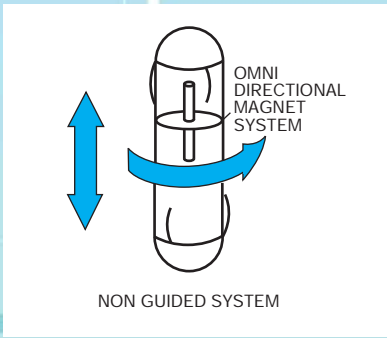

Magnetic Level Gauge SWITCHES

Simple Latching Operation Suitable for IS Circuits with Approved Barriers
 Readily Adjustable Explosion Proof Designs
 0.5 to 6 Amp Options Micro Switch and Inductive proximity Options

TC Klinger Magnetic Gauge switches, attached to the side of the chamber can be used to provide a variety of alarm functions. The range comprises of three basic types, DR2, DR3 and DR8 series for a low cost solution on temperatures up to 150°C, with connection via a flying lead - available in non-hazardous, intrinsically safe and explosion proof options. The DR4 for high temperature applications in non-hazardous environments (with inductive proximity variants) and the DR6 for explosion proof applications, plus heavy duty switching via microswitch operation.

Other options are available on request including:-

- > Special Variants for switching PLC control circuits
- > NAMUR Circuit options to DIN 50227
- > Pneumatic operation

Type DR2, DR3, DR8

| | |
|--------------------|--|
| Contact | Reed Contact |
| Contact Type | 1 SPDT (Bistable) |
| Switch Rating | 230V AC, 60VA, 1 AMP 230V DC, 30W, 0.5 AMP (for intrinsically safe circuits, certified 100mA and 30V maximum) |
| Max. Temperature | 150°C |
| Cable Connection | 3 metre silicon (longer on request) (Junction Box available on request) |
| Housing | Stainless Steel |
| Housing Protection | IP65 (IP68 EExd version) |
| Marking | DR3 Non Hazardous - None DR2 Intrinsically Safe - II 1G EEx ia IIC T3-T6 DR8 Explosion Proof - II 2G EEx d IIC T3-T6 LCIE 01 ATEX 6047X |

Type DR4

| | |
|--------------------|--|
| Contact | Reed Contact (Latching Rocker Arm) |
| Contact Type | 1 SPDT (Bistable) |
| Switch Rating | 230V AC, 60VA, 1 AMP 230V DC, 30W, 0.5AMP |
| Max. Temperature | 380°C |
| Cable Connection | M20 Entry |
| Housing | Aluminium (Coated Red) |
| Housing Protection | IP65 |

(Note - Inductive Proximity Version available on request)

Type DR6

| | |
|--------------------|--|
| Contact | Reed Contact |
| Contact Type | 1 SPDT (Bistable) |
| Switch Rating | 230V AC, 60VA, 1 AMP 230V DC, 30W, 0.5 AMP |
| Max. Temperature | 150°C |
| Cable Connection | 1 x M20 entry (2 plugged 3/4" NPT) |
| Housing | Aluminium (Coated Grey) |
| Housing Protection | IP66 |
| Marking | Explosion proof - II 2G EEx d IIC T5 - T6 LCIE 02 ATEX 6056 |

(Note - Micro switch option available - up to 6amp capacity)

Type DR2, DR3, DR8

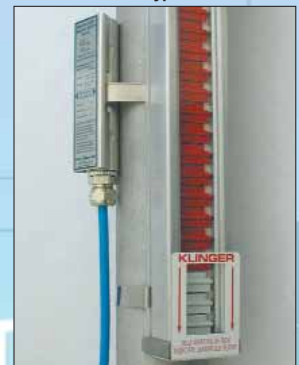

LATCHING CHANGEOVER

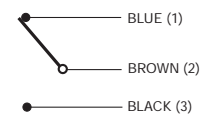

Type DR4



LATCHING CHANGEOVER

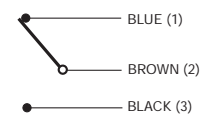

Type DR6



LATCHING CHANGEOVER



Magnetic Level Gauge **TRANSMITTERS**

Liquid Level Transmitter

KTX.IS (Intrinsically Safe)

 II 2G EEx ia IIC T4-T6 KEMA 04 ATEX 1232X

KTX.EXD (Explosion Proof)

 II 2G EEx d IIC T4-T6 LCIE 03 ATEX 6155

- > Two wire 4-20mA current loop.
- > Resolution 5mm, 10mm, 20mm Standard.
- > Remote display and control.
- > Transmits up to 6Km.
- > No media contact.
- > Simple application.
- > Can be retro-fitted.
- > Cost effective level measuring system.
- > Approved EEx ia IIC T4-T6, EEx d IIC T4-T6.
- > Low cost Non Approved version.
- > HART® - Protocol (optional).
- > PROFIBUS® PA (optional).
- > FOUNDATION™ FIELDBUS (optional).

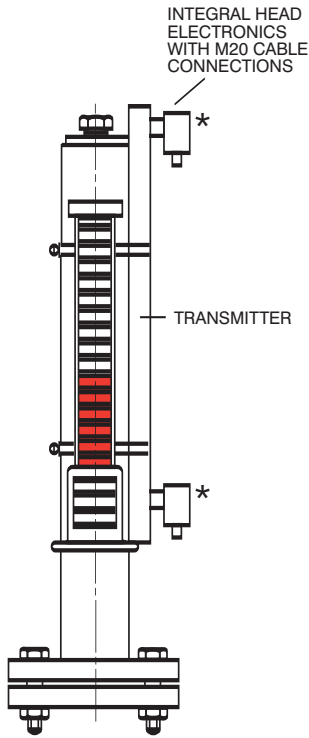
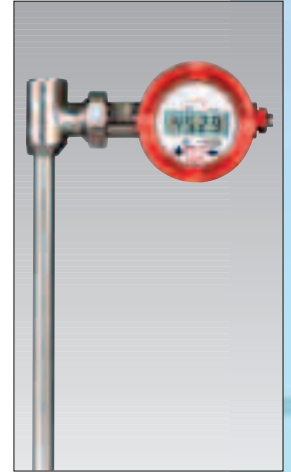

KTX TRANSMITTER
* Alternative Mounting

The transmitter is attached to the side of the magnetic level gauge chamber where it senses the position of the float. It can be supplied as an original equipment package or retro-fitted to an existing magnetic gauge, without interrupting the process.

The transmitter consists of a sensor tube containing a series of reed switches and resistors and an electronic circuit contained within a connection head, which can be supplied orientated to suit any gauge configuration or cable arrangement.

As the float rises and falls within the gauge chamber the corresponding reed switch closes altering the circuit resistance, this resistance is converted into a 4-20mA output signal by the electronic circuit.

The transmitter is approved intrinsically safe to EEx ia IIC T4-T6 when used with approved barriers.

For explosion proof duty approved to EEx d IIC T4-T6.

■ **Specification**

Supply voltage 10-30Vdc. Polarity protected

Output 4-20mA (profiled optional)

Float warning - Default Signal

Connections via epoxy coated aluminium head mounted junction box with M20 cable entry

Protection IP65

Lengths to suit magnetic level gauge

Stainless Steel headshell option

For enquiry information: Refer to Separate Order Form

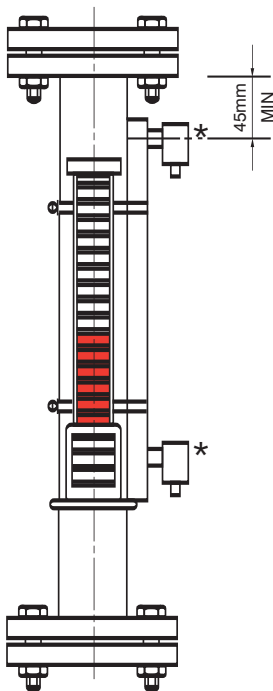

FLANGED END CONNECTED ARRANGEMENT

■ Specification

STANDARD MATERIALS

Body: Austenitic stainless steel to suit customers requirements.

Flanges: Austenitic stainless or carbon steel depending upon application.

Float: Austenitic stainless steel, titanium or corrosion resistant plastic.

Display Housing: Aluminium Alloy 6063T6 or Stainless Steel Clad.



RATINGS

Process Pressures up to 400 bar (5800 psi).
Saturated Steam pressure up to 150 bar.
Temperatures up to 400°C.
Higher temperatures on application.



SPECIAL CHAMBER MATERIAL

Alloy 825, Titanium, Hasteloy, Sanicro 28/Duplex, Monel 400.
Others on request.



■ Approvals

CE PRESSURE EQUIPMENT DIRECTIVE
97/23/EC CATEGORY IV
Type Approval COV 0312119/TEC
Module B
Certificate of Conformity COV 0312785/01
Module D

Ex II 1/2 Gc T1-T6 SIRA 04 ATEX 6126

Note: this approval is not available on all options, contact design office for information.



TC Fluid Control Ltd. Valves and Steam Division
Broadgate, Broadway Business Park,
Chadderton, Oldham, Lancashire OL9 9XA.
Telephone: +44 (0)161 684 7488.
Fax: +44 (0)161 684 7487.
e-mail: energy@tc-fluidcontrol.com
web site: www.tc-fluidcontrol.com

TC Fluid Control Ltd. Instrumentation Division
Unit 49A, Victoria Industrial Park,
Victoria Road, Dartford, Kent DA1 5AJ
Telephone: +44 (0)1322 622400
Fax: +44 (0)1322 285660
e-mail: instruments@tc-fluidcontrol.com
website: www.tc-fluidcontrol.com



DISTRIBUTED BY