

CAUTION:

If any questions arise concerning the proper installation or maintenance of our products, please contact Protectoseal or one of our Authorized Representatives.

When installing any Protectoseal device, the legal, corporate and advisory safety regulations and procedures appropriate for the specific installation site must be fully understood and followed.



- NOTE 1:** This vent style includes a removable cover and weatherhood. The hood stem guide may be taped to the top of the hood to prevent damage during shipment. The stem guide will be threaded into the tapped hole on top of the hood.
- NOTE 2:** When pressure or vacuum weights (packed separately if heavy) are included with a unit, the weights should be inspected, properly identified and set aside for later installation. Weights will be stamped with a serial number matching the number on the vent; identification as pressure or vacuum weights; and a statement as to the contribution that each weight provides to the total pressure or vacuum setting.

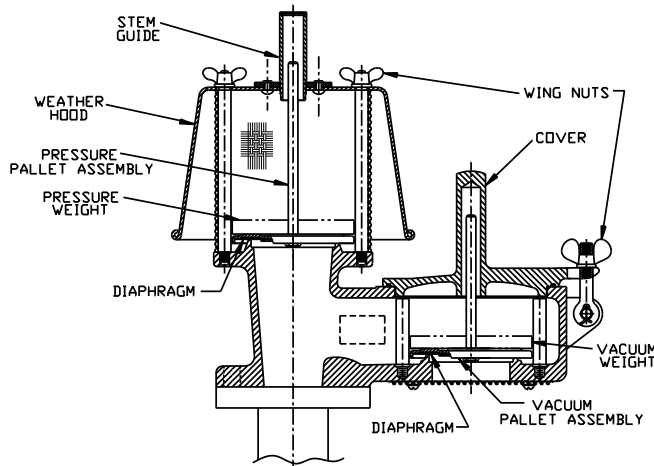

INSTALLATION PROCEDURE:

- Loosen wing nuts and remove cover and weatherhood.
- Withdraw pressure and vacuum pallet assemblies. Remove and discard protective cardboard and tape from each assembly. The cardboard protects the diaphragms during shipment.
- Remove protective flange covers.
- Check carefully to insure that all packing materials are removed from on or inside the vent housing and from the pallet assemblies.
- Mount the vent to the appropriate tank flange using gaskets compatible with service conditions. Note: For some vent styles, threaded studs that mate with tapped holes in the vent housing flange are provided. For best performance, the vent should be mounted level so that the seating surfaces are no more than 1° off horizontal.
- Reinstall the pressure and vacuum assemblies into their respective openings. Setting weights (if provided) should be installed by engaging the hole in the weight on the appropriate pallet assembly stem. Make sure that weights are properly installed as marked to provide specified set points. Heavy weights may be provided with tapped holes to temporarily attach lifting hardware to facilitate installation. Any such threaded fasteners used during installation must be removed from the weights. Foreign objects will limit the lift capability of the pallet assemblies and will reduce rated flow capacity of the vent.
- Replace the cover and weatherhood. Note: Make sure that the respective pressure and vacuum pallet assembly stems positively engage the hole in the stem guide in the weatherhood and in the cover. It may be useful to verify engagement of the pressure stem into the weatherhood stem guide by unthreading the guide and then reinstalling it with the stem centered in the hole. Each pallet assembly must be free to move upwards, with the pallet stem traveling into the stem guide.
- Secure cover and hood with wing nuts or nuts.

MAINTENANCE:

Protectoseal recommends that our products be inspected and maintained according to the normal maintenance schedule of the facility. At a minimum, maintenance should be conducted annually. More frequent maintenance may be required, and should be scheduled, for unusual service conditions.

CAUTION: When maintaining any Protectoseal device, the legal, corporate and advisory safety regulations and procedures appropriate for the specific installation site must be fully understood and followed.

CAUTION: Tank vapor space pressure or vacuum should be relieved before any maintenance operations are undertaken.

MAINTENANCE PROCEDURE:

- Loosen wing nuts and remove cover and weatherhood.
 - Inspect the gasket on the cover. Replace if deteriorated or damaged.
 - Remove any loose dirt or foreign material from the housing interior and exterior. Check inside the stem guide hole of the weatherhood and cover and remove any dirt or accumulation of foreign material from these holes.
 - Withdraw the pressure and vacuum pallet assemblies and any weights. Set aside for inspection. Note: Identify any weight on the pressure and vacuum pallet assemblies for later reinstallation.
 - Inspect the screens that protect the pressure and vacuum ports. Clean or replace as necessary.
 - Inspect and clean the machined seating surfaces in the vent housings with a suitable cleaning fluid. Seat should be free of nicks, mars or accumulations of foreign material.
- Inspect the pallet assemblies. If pallets are deteriorated or bent, they must be replaced. Inspect the diaphragm materials in the pallet assemblies. The diaphragms must be clean, flat and smooth. If the diaphragm material is deteriorated, it must be replaced. Make sure that all nuts and screws on the pallet assemblies are tightened securely.
 - Reinstall the pressure and vacuum pallet assemblies into their respective openings. Setting weights (if provided) should be installed by engaging the hole in the weight on the appropriate pallet assembly stem. Make sure that weights are properly installed as marked to provide specified set points. Heavy weights may be provided with tapped holes to temporarily attach lifting hardware to facilitate installation. Any such threaded fasteners used during installation must be removed from the weights. Foreign objects will limit the lift capability of the pallet assemblies and will reduce rated flow capacity of the vent.
 - Replace the cover and weatherhood. NOTE: Make sure that the respective pressure and vacuum pallet assembly stems positively engage the hole in the stem guide in the weatherhood and in the cover. It may be useful to verify engagement of the pressure stem into the weatherhood stem guide by unthreading the guide and then reinstalling it with the stem centered in the hole. Each pallet assembly must be free to move upwards, with the pallet stem traveling into the stem guide.
 - Replace wing nuts or nuts and tighten to secure cover and weatherhood.

ADDITIONAL PRODUCTS FROM PROTECTOSEAL

Series 18540



Pipe-Away Pressure Vacuum Relief Vent for applications that require hazardous vapors be processed into manifolded piping and not released into the atmosphere

Series 7800



Emergency Vent protects tanks against rupture or explosion resulting from excessive internal pressure caused by exposure to fires.

Series 4950



Vent Line / In-Line Parallel Plate Flame Arrester is designed for installation in open vent pipe or bleed lines from storage or processing tanks. Suitable for NEC Group D (IEC Group IIA) vapors

Series 830



Combination Pressure / Vacuum Relief Vent & Flame Arrester provides pressure and vacuum relief as well as protection from propagation of externally introduced flames. Suitable for NEC Group D (IEC Group IIA) vapors.